

Product Range International 2016

# INSTAFLEX iFIT





# Table of contents

## **General information**

The best choice for you	5
The GF world of plastic piping	6
Individual service for your needs	11
Value added services	12
Sustainability	14
We take responsibility	15
Environmental product declaration	16
Approvals INSTAFLEX	18
Technical Data INSTAFLEX	20
Prefabrication / Installation made easy	23

## **INSTAFLEX**

Pipes	34
Working with INSTAFLEX	36
Valves	44
System adapters	64
Pipe outlets	74
Electro fusion jointing HWS	80
Socket fusion jointing HMS	102
Butt fusion	116
Compression jointing	120
Machines & Tools	132
Seminar and training documents	147

## **iFIT**

System Overview iFIT	150
Working with iFIT	152
Approvals iFIT	153
Technical Data iFIT	155
Tools	184
Code Index	186

# General information

<b>Al</b>	Aluminium
<b>BF</b>	Butt fusion
<b>Brass</b>	Alloy made of copper and zinc (wetted parts in dezincification resistant quality, DZR brass)
<b>d</b>	Pipe outside diameter
<b>dCu</b>	Copper pipe outside diameter
<b>DN</b>	Nominal bore
<b>EPDM</b>	Ethylene propylene diene monomer (M-class) rubber
<b>EPS</b>	Expanded Polystyrene
<b>EVOH</b>	Ethylene vinyl alcohol
<b>EF</b>	Electro fusion
<b>Gunmetal</b>	Known as red brass in the United States, type of bronze an alloy of copper, tin and zinc
<b>HWS</b>	Heiz-Wendelschweissen, GF Electro fusion system
<b>HMS</b>	Heiz-Muffenschweissen, GF Socket fusion system
<b>Malleable Cast iron</b>	Cast iron that has been toughened by gradual heating or slow cooling
<b>PA-GF</b>	Polyamide glass-fibre reinforced
<b>PB</b>	Polybutene
<b>PE</b>	Polyethylene
<b>PE-HD</b>	Polyethylene, high density
<b>PE-RT</b>	Polyethylene
<b>PE-Xa</b>	Cross-linked polyethylene, using the peroxide (Engel) method, after the installation, PE-Xb has the same properties as PE-Xa
<b>PE-Xb</b>	Cross-linked polyethylene, using the silane method after the installation, PE-Xb has the same properties as PE-Xa
<b>PE-Xc</b>	Cross-linked polyethylene, using the electron beam process
<b>PP</b>	Polypropylene
<b>PPSU</b>	Polyphenylsulfone
<b>s</b>	Wall thickness of the pipe
<b>Ø</b>	Diameter
<b>UBA</b>	Umwelt Bundesamt, Germany
<b>LK</b>	Hole circle
<b>SW</b>	Dimension across flats (A/F)
<b>SF</b>	Socket fusion
<b>G</b>	Pipe thread, not pressure tight in the thread (with flat seat) to ISO 228
<b>R</b>	Taper male thread, pressure tight in the thread to ISO 7
<b>Rp</b>	Parallel female thread, pressure tight in the thread to ISO 7
<b>M</b>	Metric thread to ISO 261
<b>m</b>	Meter
<b>SP</b>	Items per standard pack
<b>g</b>	Gramme

All dimensions are given in mm and are intended as nominal or outside diameter of the pipe. Subject to alteration resulting from modifications in design.

For compressed air applications with air containing mineral oil, EPDM gaskets must be replaced by NBR units.

NBR gaskets are not contained in this Product Range. Please contact the GF Piping Systems sales consultant or sales support office assigned to your sales area.

Technical changes and mistakes reserve.



# The best choice for you

## Corrosion and chemical resistant system solutions

GF focuses on three core businesses: GF Piping Systems, GF Automotive and GF Machining Solutions. The industrial corporation founded in 1802 headquarters in Switzerland and operates approximately 130 companies with more than 14 000 employees across 30 countries.

GF Piping Systems is a leading supplier of plastic and metal piping systems with global market presence. For the treatment and distribution of water and chemicals, as well as the safe transport of liquids and gases in industry, we have the corresponding jointing technologies, fittings, valves, automation products and pipes in our portfolio.



GF Piping Systems headquarters in Schaffhausen, Switzerland.

Being a strong partner, GF Piping Systems supports its customers in every phase of the project. No matter which processes and applications are planned in the following market segments:

- Building Technology
- Chemical Process Industry
- Energy
- Food & Beverage / Cooling
- Microelectronics
- Marine
- Water & Gas Utilities
- Water Treatment

### + Global presence

Our global presence ensures customer proximity worldwide. Sales companies in over 26 countries and representatives in another 80 countries provide customer service around the clock. With 48 production sites in Europe, Asia and the USA we are close to our customers and comply with local standards. A modern logistics concept with local distribution centers ensures highest product availability and short delivery times. GF Piping Systems specialists are always close by.

### + Complete solutions provider

Our extensive product range represents a unique form of product and competence bundling. With over 60 000 products, allied with a broad range of services, we offer individual and comprehensive system solutions for a variety of industrial applications. Our automation offering perfectly fits into our complete system approach and is thus an integral part of our portfolio. Having the profitability of the project in focus, we optimize processes and applications that are integrated into the whole system.

Continually setting standards in the market, we directly provide our customers with technological advantages. Due to our worldwide network customers benefit directly from over 50 years of experience in plastics.

### + Our market segments

From start to finish, we support our customers as a competent, reliable and experienced partner, actively contributing the know-how of an industrial company that has been successful in the market for over 200 years.



GF Corporate Movie  
All Divisions

# The GF world of plastic piping

System	Material	Colour	Flammability
ABS	ABS	Mid Grey	Bright flame, drips, continues to burn away from flame
AQUASYSTEM	PP-R	Light brown Green/Grey	Bright flame, drips, continues to burn away from flame
Harvel Blazemaster	PVC-C	Orange	In flame carbonises, extinguishes away from flame
CONTAIN-IT Plus	PE100&PVC-U Containment pipe/ inside variable	Black/Grey/ Transparent	Bright flame, drips, continues to burn away from flame
CONTAIN-IT	PVC-U/inside variable	Transparent	In flame carbonises, extinguishes away from flame
COOL-FIT ABS Plus	ABS/PUR/PE	Black	Bright flame, drips, continues to burn away from flame
COOL-FIT PE Plus	PE/PUR/PE	Black	Bright flame, drips, continues to burn away from flame
Double-See	PVC-U&PVC-C (Containment)	Transparent	In flame carbonises, extinguishes away from flame
ecoFIT	PE100&PE80	Black	Bright flame, drips, continues to burn away from flame
ELGEF Plus	PE	Black	Bright flame, drips, continues to burn away from flame
FUSEAL	PP-NFR	Grey/Blue	In flame carbonises, extinguishes away from flame
FUSEAL 25/50	PVDF	Blue	In flame carbonises, extinguishes away from flame
iFIT	PB, ML, PEX	White	Normal flammable
INSTAFLEX	PB	Grey	Continues to burn away from flame
MULTI/JOINT	GGG45/NBR or EPDM	Red/Black	Metal, non-flammable
PRIMOFIT	Malleable cast iron	Black/Galvanised	Metal, non-flammable
PROGEF Natural	PP-R	Transparent	Bright flame, drips, continues to burn away from flame
PROGEF Standard	PP-H&PP-R	Light Beige	Bright flame, drips, continues to burn away from flame
PROGEF Plus	PP-H&PP-R	Light Beige	Bright flame, drips, continues to burn away from flame
PVC-C	PVC-C	Light Grey	In flame carbonises, extinguishes away from flame
PVC-U	PVC-U	Dark Grey	In flame carbonises, extinguishes away from flame
PVC-U clear	PVC-U	Transparent	In flame carbonises, extinguishes away from flame
SANIPEX MT	PE-x/Al/PE-x	Black	
SeaCor	PVC-C	Dark Grey	In flame carbonises, extinguishes away from flame
SYGEF Plus	PVDF HP (High purity)	White - Opaque	In flame carbonises, extinguishes away from flame
SYGEF Standard	PVDF	White - Opaque	In flame carbonises, extinguishes away from flame
Harvel Shapes **	PVC/CPVC - PP/HDPE	Various/Custom	In flame carbonises, extinguishes away from flame

System	Operating Temperature																Dimension		
	-50	-40	-30	-20	-10	0	10	20	30	40	50	60	70	80	90	100		110	120
ABS	-50° C to +60° C (d250 - d315 oper. temp +40° C)																d16 - d315, <sup>3</sup> / <sub>8</sub> - 8 inch		
AQUASYSTEM	0° C to +95° C																d20 - d125		
Harvel Blazemaster	0° C to +80° C																<sup>3</sup> / <sub>4</sub> - 3"		
CONTAIN-IT Plus	-40° C to +140° C																d50/20 - d315/225		
CONTAIN-IT	-0° C to +60° C (outer)																4 + 6" outer		
COOL-FIT ABS Plus	-50° C to +40° C																d25 - d315		
COOL-FIT PE Plus	-50° C to +50° C																d250 - d450		
Double-See	0° C to +60° C																1 1/2 - 10"		
ecoFIT	-50° C to +60° C																d20 - d630 *		
ELGEF Plus	-50° C to +60° C																d20 - d2000		
FUSEAL	0° C to +100° C																1 1/2 - 18"		
FUSEAL 25/50	0° C to +140° C																1 1/2 - 6"		
iFIT	0° C to +95° C																d16 - d32		
INSTAFLEX	-10° C to +95° C																d16 - d225		
MULTI/JOINT	-5° C to +50° C																d50 - d2000		
PRIMOFIT	-20° C to +105° C																<sup>3</sup> / <sub>8</sub> - 4 inch/d20-d63		
PROGEF Natural	0° C to +80° C																d20 - d110		
PROGEF Standard	0° C to +80° C																d16 - d500		
PROGEF Plus	0° C to +80° C																d20 - d315		
PVC-C	0° C to +80° C																d16 - d225, <sup>1</sup> / <sub>4</sub> - 24 inch		
PVC-U	0° C to +60° C																d6 - d400, <sup>1</sup> / <sub>8</sub> - 24 inch		
PVC-U clear	0° C to +60° C																1/4 - 12"		
SANIPEX MT	0° C to +95° C																d16 - d63		
SeaCor	0° C to +80° C																1/2 - 6"		
SYGEF Plus&Standard	-20° C to +140° C																d16 - d450		
Harvel Shapes **	0° C to +80° C																1/4 - 12" (up to 22" PP/HDPE)		

Jointing	Density (g/cm <sup>3</sup> )	System	Nominal Pressure (PN)
Solvent cement	1.03	ABS - BS inch	PN15 (Class E 3/8 - 4")
Butt, socket&electro fusion	0.90		PN12 (Class D 6")
Solvent cement&mechanical	1.55		PN9 (Class C 1 - 8")
Depending on material	-	ABS - Metric	PN12 (Class 7T 1/2 - 2")
Solvent cementing	-		PN10 (d20 - d225)
Solvent cementing	-	AQUASYSTEM	PN6 (d250 - d315)
Electro fusion	-	Harvel Blazemaster	PN depending on size (1/2 - 3") Schedule System
Solvent cement	1.4-1.52	CONTAIN-IT Plus	PN depending on material
Butt, socket, IR&electrofusion	0.93-0.95	CONTAIN-IT	PN3 Schedule System
Electro fusion	-	COOL-FIT ABS Plus	PN10 (d25 - d225)
Electro fusion	0.9	COOL-FIT ABS Plus	PN6 (d250 - d315)
Electro fusion	1.78	COOL-FIT PE Plus	PN10 (d250 - d450)
Push fit	0.94	Double-See	PN4
Butt, socket&electro fusion, compression	0.94	ecoFIT	PN16 (d20 - d630)
Mechanical joints	-		PN10 (d50 - d630)
Mechanical joints	-	ELGEF	PN16 (d20 - d1 000)
Butt, BCF&IR	0.90		PN10 (d160 - d2 000)
Butt, socket fusion&IR	0.90	FUSEAL	PN depending on size (1 1/2 - 18")
Butt, socket fusion&IR	0.90	FUSEAL 25/50	PN depending on size (1 1/2 - 6")
Solvent cement	1.5	iFIT	PN10
Solvent cement	1.38	INSTAFLEX	PN16 (up to d110; PN10 d125 - d225)
Butt fusion, Socket fusion	1.38	MULTI/JOINT	PN16 (restraint)
Mechanical joints	0.905		PN25 (non restraint)
Solvent cement	1.38	PRIMO FIT	PN16
Butt fusion, BCF&IR	1.78	PROGEF Natural	PN10 (d20 - d63)
Butt, socket fusion, BCF&IR	1.78		PN6 (d75 - d110)
Generally N/A-semi finished shape for machining	-	PROGEF Standard	PN10 (d16 - d500)
			PN6 (d50 - d500)
		PROGEF Plus	PN10 (d20 - d315)
		PVC-C Metric	PN16 (d16 - d160)
			PN10 (d75 - d225)
		PVC-C SCH80/40	PN depending on size (1/4 - 24")
Excellent for cold water and chilled applications		PVC-U BS INCH	PN16 (Class E 3/8 - 6")
Excellent temperature - pressure behaviour			PN12 (Class D 1/4 - 4")
Fire Sprinkler system			PN9 (Class C 2 - 8")
Safely conveying hazardous media with process reliability		PVC-U SCH80/40	PN12 (Class 7T 3/8 - 2")
Safely conveying hazardous media with process reliability			PN depending on size (1/8 - 24")
Three-in-One system, excellent properties		PVC-U Metric	PN16 (d6 - d160)
Three-in-One system, excellent properties			PN10 (d25 - d315)
Safety system to transport hazardous media			PN6 (d50 - d400)
UV&weather resistance, flexible and strong at low temperature		PVC-U clear SCH80/40	PN depending on size (1/4 - 12")
Leak free welded system		SANIPEX MT	PN10 (d16 - d63)
Resistant to alkalis, alcohols, acids, solvents and salt solutions		SeaCor	PN depending on size (1/2 - 6")
Resistant to alkalis, alcohols, acids, solvents and salt solutions		SYGEF	PN16 (d16 - d225)
Easy jointing, for all building services applications		Plus&Standard	PN10 (d90 - d450)
Hot and cold water sanitary system, compressed air		Harvel Shapes **	N/A-solid rods/tubes/profiles-semi-finished, optimal machining
Connection to all types of pipes			
Corrosion retarding, drinking water friendly			
Pigment free polypropylene with smooth surface			
High stress fracture-, pressure-, abrasion-, corrosion resistance			
Silicon-free or oil-free system with a high pureness factor			
Chemical and higher temperature resistant			
Easy and fast to joint, very good chemical resistance			
Visual monitoring of Process			
Hot and cold water system, hygienically perfect			
USA coast guard approved piping			
High purity, outstanding chemical resistance, UV-resistant			
Semi-finished rod/tube/profiles, optimal for machining, excellent chemical & corrosion resistance			

Benefit		inch - metric ranges (mm)	
		(Pipe Sizes nearest equivalent)	
inch	3/8 1/2 3/4 1 1 1/4 1 1/2 2 2 1/2 3 4 4 5 6 6 8 8 10 10 12 14 16 18 20 20 24	d	16 20 25 32 40 50 63 75 90 110 125 140 160 180 200 225 250 280 315 355 400 450 500 560 630
DN	10 15 20 25 32 40 50 65 80 100 100 125 150 150 200 200 250 250 300 350 400 450 500 500 600		

d = mm  
\* For more information about larger dimensions please contact our local sales companies.  
Visit our website for more detail system information: [www.gfps.com](http://www.gfps.com)  
\*\* Detail Harvel Shapes Information: [www.harvelshapes.com](http://www.harvelshapes.com)

# System Overview

## INSTAFLEX

INSTAFLEX – the plastic piping system made of polybutene for applications in building services. Ideally suited for hot and cold water, cooling systems and compressed air. This system includes everything for conveying water from the basement to the tapping points.

Available in dimensions d16-d225.



GF Piping Systems  
Product Movie INSTAFLEX

# INSTAFLEX fits your application best

## + System solution

You benefit from the advantages of a system solution made of plastic for your installation from the building entry to the last tap. A single material from the basement to the roof.

## + Efficiency

You benefit from optimal cost. Prefabricated components reduces on-site time and costs.

## + Safety

You reap the benefits of having a permanently leak-proof and durable drinking water system.

## + Maintenance

The longevity of your drinking water system secures low maintenance.

## + Hygiene

INSTAFLEX made of polybutene provides safe and hygienic water.

## + Lifetime

Using INSTAFLEX, you benefit from the long lifespan of the material. Operating at 10 bar and 70°C, this system is designed for 50 years lifespan - the equivalent of two generations.

## + Solvent-free

INSTAFLEX is a solvent free ideal for drinking water system. During normal operation, the smooth pipe surface prevents deposits.

## + Corrosion-free

Installing INSTAFLEX, you have the advantages of a corrosion free drinking water system. Even during prolonged stagnation times no rusty water.

## + Life Cycle Assessment

Installing INSTAFLEX, you use the advantages of a material that can be fully recycled and has a low carbon footprint.





# Building Technology

# Individual service for your needs

Customer needs are in the center of whatever GF does. From on-site training to adapted design and tailor-made processes - GF Piping Systems provides individual service which fits customers best.

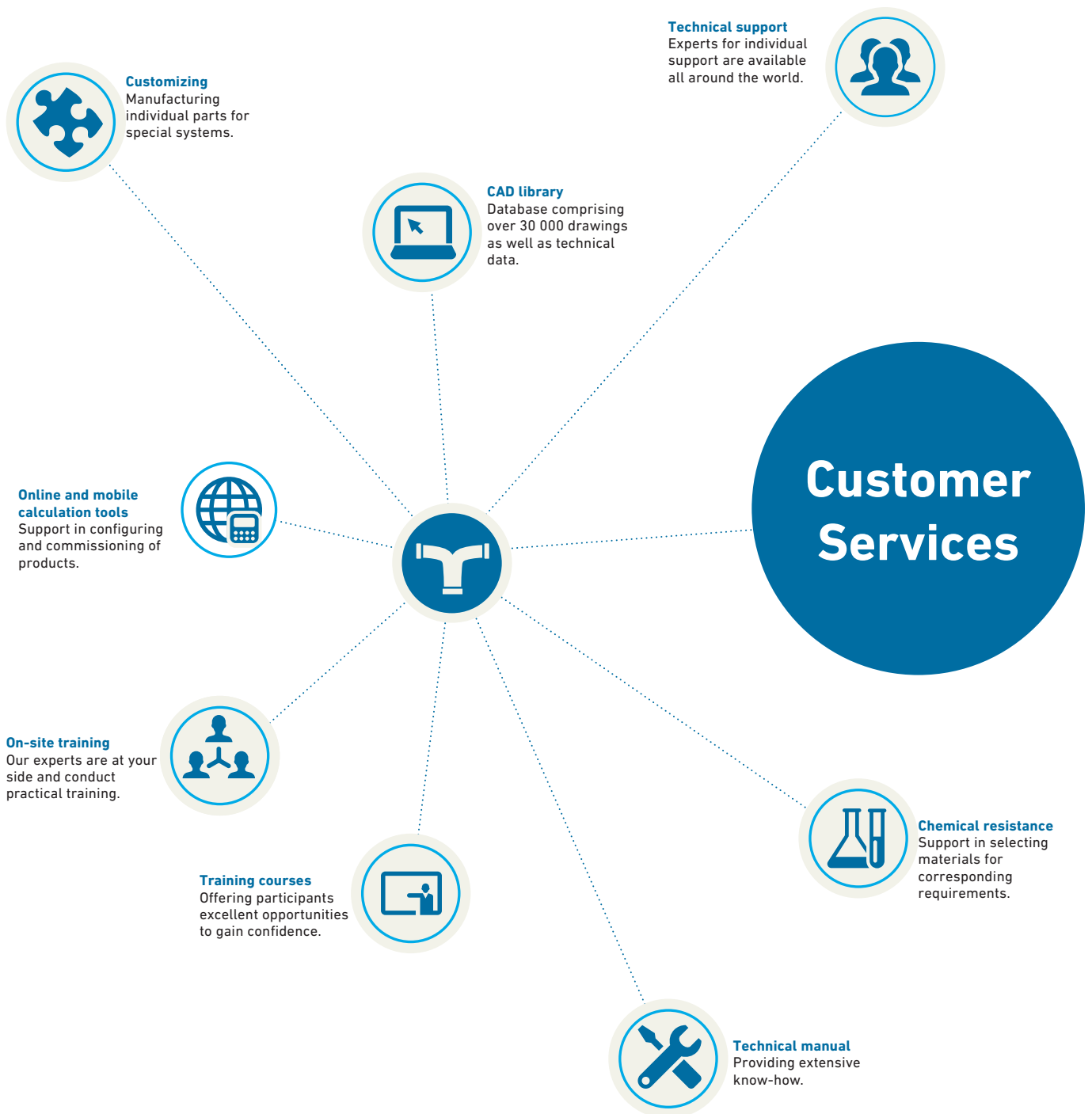

# Value added services

## From planning support to implementation – our specialists are always close by

As a leading provider of piping systems in plastic and metal, we offer our customers not only reliable products, but also a large package of services. Our support ranges from a comprehensive technical manual or the extensive CAD library to an international team of experts, who work closely together with local sales companies. And when it comes to implementing a project, our customers additionally benefit from a wide range of training courses, either on site or in our modern training centres worldwide.

Generating a genuinely individual added value for our customers is our ultimate goal when implementing our tailor-made solutions. With our application knowledge and product expertise, we support our customers during the planning process, the sustainable realization of the projects and the provision of services. Our expertise in developing and producing piping systems, combined with our profound industry and market knowledge, based on longstanding experience, makes us a qualified and professional partner for our customers.

### 1 Chemical resistance

Our specialist teams have decades of experience in the area of chemical resistance. They can offer individual support and advice in selecting the right material for the corresponding system solution. On request, a team will examine and select the appropriate material for special applications.

### 2 CAD library

The extensive CAD library is the most frequently used planning tool at GF Piping Systems. The database comprises over 30 000 drawings and technical data regarding pipes, fittings, measurement and control technology as well as manual and actuated valves. The big advantage of the CAD library is that the data can be integrated directly in CAD models.

### 3 Technical support

Technical support and material selection are key factors for a successful installation. A team of specialists headquartered in Switzerland is available to support the GF Piping Systems sales companies around the world. For technical advice or for general information, our customers are supported individually by the specialist team in the corresponding sales company.

### 4 Online and mobile calculation tools

Our numerous, multilingual online calculation tools are very useful for configuring and calculating. By means of pressure/temperature diagrams, the pressure of liquid media recommended for pipes and fittings at various temperatures can be easily defined. FlowCalc App, the mobile application of GF Piping Systems, is an on-site planning tool for pipe diameter and flow velocity calculation to select the right dimension of piping systems when no expert is near by.

### 5 On-site training

Our experts are available to support our customers locally and conduct training in diverse fusion and jointing techniques on location. The duration and structure of the training depends on the project and the system being installed.

### 6 Customizing

The customizing teams at GF Piping Systems work closely together around the globe. The focus of these teams is to manufacture custom parts for special systems. In addition, a variety of special solutions can be produced in small series. Standardized processes warrant the highest level of quality for the individual solutions of our customers.





**7**

**Technical manual**

For our customers, we have documented the extensive know-how of GF Piping Systems in planning and installing plastic piping systems in our technical manual. This detailed documentation is available in both printed and digital version. The established reference book is helpful in planning large and small projects.

**8**

**Training courses**

GF Piping Systems offers a wide range of training courses that allow participants to gain confidence in working with our products and proven jointing technologies. The practical training is clearly defined, structured and adapted to the various levels of participants' experience.

# Sustainability

GF Piping Systems incorporates its environmental responsibility into its everyday business activities. Because we understand environmental awareness as one of the corporation's core values, all internal structures and processes are geared towards sustainability. We strive to conserve natural resources and work continually towards optimizing the environmental performance of our products and how they are used. Consequently, outstanding material properties and innovative technologies form the basis for our environmentally friendly and energy-saving solutions.

## Product Life Cycle

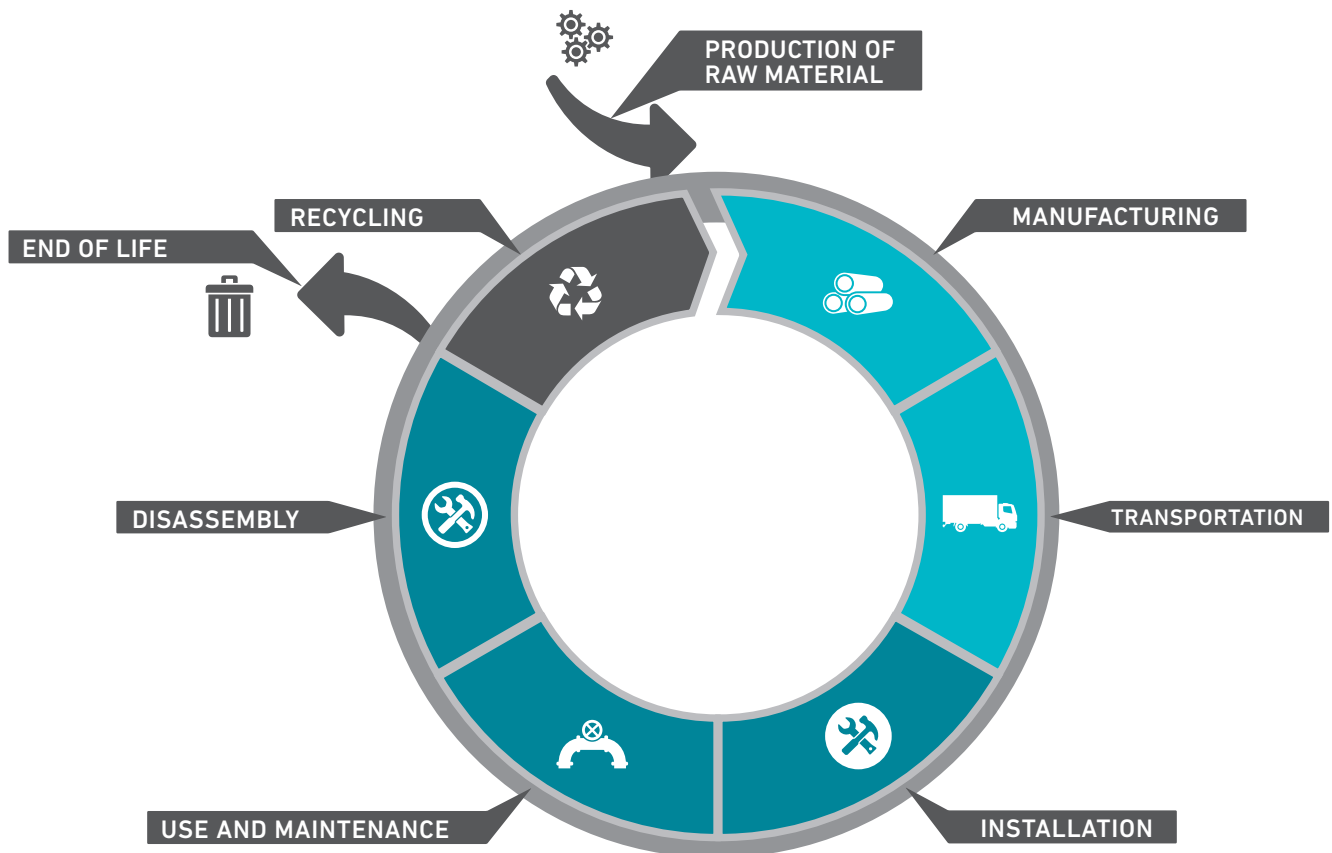

## Life Cycle Assessments of GF specific industry systems

GF Piping Systems proactively performs life cycle assessments to determine the environmental impact of its products. In cooperation with an independent institute, life cycle assessments of selected GF Piping Systems specific industry systems were calculated including a PB system for the distribution of hot and cold water on a cruise ship. The life cycle assessments cover the environmental impact over the whole life cycle.



# We Take Responsibility

Our vision is to become the world-leading provider of environment-friendly piping systems for industry, utility and building technology with focus on water cycle applications.

## Certified management systems

Deeply ingrained in our entrepreneurial consciousness, our environmental responsibility goes far beyond just meeting a standard. Management systems and established international certifications prove and document our commitment towards the environment in every aspect of our activities. Each of our worldwide production companies is certified according to ISO 14001. Defining criteria which are globally applicable to efficient environmental management systems, the norm forms the basis for the optimization of processes relevant to the environment. Furthermore, as part of our sustainability activities, all manufacturing sites are already certified according to OHSAS 18001 or are currently in the certification process to acquire this international occupational health and safety management system specification.

## Reporting

GF began integrating sustainability requirements in its international operations early on by establishing a clearly defined organization and a system of internal reporting. The GF Corporation provides periodic reports on its performance in the area of sustainability. Environmental as well as social data are gathered annually via the Sustainability Information System. With this system, GF surveys its corporate subsidiaries to gather key indicator data in line with the Global Reporting Initiative (GRI). The guidelines of the Global Reporting Initiative lay down requirements for corporate sustainability reporting that are recognized throughout the world.



GF Piping Systems  
Sustainability

# Environmental Product Declaration

## System

As an abstract of the Life Cycle Assessment (LCA) you will find following EPD (Environmental Product Declaration) regarding Polybutene installation. The entire EPD has been made according to ISO 15804 and is available for download on our website: [www.gfps.com/sustainability](http://www.gfps.com/sustainability)

The analyzed case represents an exemplary system for the transport of fresh water to the cabins of a cruise ship. The installed piping system consists of the dimensions d110 (riser), d50 (decks) and d16 (cabins). The ship which has a length of 340 m comprises 18 decks with a length of 280 m and a total of 1 800 cabins. The system is installed in a dockyard in Turku (Finland). The used jointing technologies are socket welding and electrofusion.

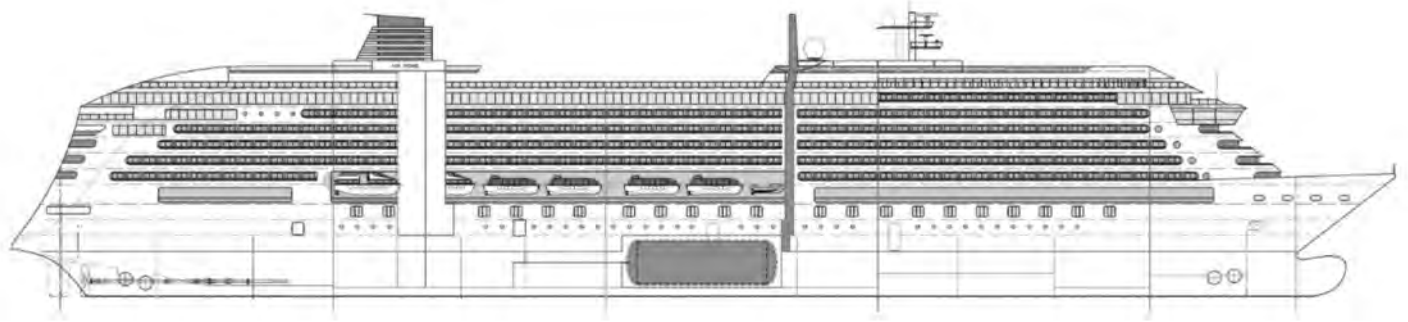

## Materials

The material of the main pipe system components (pipes and fittings) is PB. The whole system consists of the materials as listed below.

## Reference service life time

20 years

## Functional unit (FU)

The transport of hot and cold water in a PB piping system on a cruise ship via a riser (d110) and the decks (d50) to the taps of the toilet, shower and sink in the cabins (d16) over the whole lifetime of the system.

## Transferability of results to land based applications

From a piping system perspective, a cruise ship is nothing different than a swimming house. The installed product to provide hot and cold water on a ship are the same as installed in land based applications (like a hotel, hospital or an apartment building) to provide the same service.

The data in the EPD refer exactly to the scope and functional unit defined in the underlying LCA. However, the environmental impacts of an LCA calculated for a land based application would still indicate the product phase and the use phase as the two dominant phases.

Material	Weight (kg)
PB	10 777
Brass	6 397
Plastics (other than PB)	403
Rubber	40
Steel	25
Paper	18
Printed wiring board	7
Other metals	6
Wire	5
Pump	
Iron	2 356
Bronze	398
Steel	217
Other metals	33
Rubber	8
Neoprene	2
Motor	
Steel	1 752
Other metals	976
Plastics	19
Insulation material	18
Chemicals organic, not specified	9
Paint	7









GF Piping Systems  
EPD INSTAFLEX, ISO 15804

The system mainly consists of GF Piping Systems components. However, to complete the system also external components (Ext.) which are not produced by GF Piping Systems are necessary. The calculation of the environmental impact of these products is based on publicly available data and assumptions.

	Product Code	Pieces or meter	Material
<b>System Components</b>			
<b>Cabin</b>			
INSTAFLEX pipe, d16	760856606	32 400 m	PB
INSTAFLEX socket, d20	761066661	3 600	PB
INSTAFLEX electrofusion reducer d20/d16	761069277	3 600	PB (body) and others
INSTAFLEX elbow 90°, d16	760854842	7 200	Brass
INSTAFLEX brass tee 90°, equal, d16	760853125	7 200	Brass
INSTAFLEX single pipe outlet with flange, d16	760853013	10 800	Brass
<b>Deck</b>			
INSTAFLEX Pipe PB, d50	760856611	10 080 m	PB
INSTAFLEX weld-in-saddle, d50-d20	761068003	3 600	PB
INSTAFLEX electrofusion coupler, d50	761069205	1 728	PB (body) and others
Ball valve type 546, d20	760000343	3 600	PP-H (body) and others
<b>Riser</b>			
INSTAFLEX pipe, d110	760856615	180 m	PB
INSTAFLEX tee 90° equal, d110	761066629	72	PB
INSTAFLEX reducing bush, d110/d63	761066747	72	PB
INSTAFLEX reducing bush, d63/d50	761066690	72	PB
<b>Pump connection</b>			
INSTAFLEX Pipe PB, d110	760856615	10 m	PB
INSTAFLEX electrofusion coupler, d110	761069267	8	PB (body) and others
INSTAFLEX electrofusion elbow 90°, d110	761069223	1	PB (body) and others
INSTAFLEX flange adapter, d110	761069315	4	PB
INSTAFLEX backing flanges PN 16, d110	761065278	4	Iron
Butterfly valve type 567, d110	167567005	2	PP-H (body) and others
Motor	Ext.	6	Various metals and others
Pump	Ext.	6	Various metals and others

### Parameters describing environmental impacts

Impact category	Global warming	Ozone depletion	Acidification of soil and water	Eutrophication	Photo-chemical ozone creation	Abiotic depletion - non fossil	Abiotic depletion - fossil
	 kg CO <sub>2</sub> eq	 kg CFC-11 eq	 kg SO <sub>2</sub> eq	 kg PO <sub>4</sub> <sup>3-</sup> eq	 kg C <sub>2</sub> H <sub>4</sub> eq	 kg Sb eq	 MJ
A1-3 Product stage	8.72E+04	7.30E-02	9.87E+02	4.23E+02	6.19E+01	1.31E+01	2.00E+06
A4 Transport to installation	4.01E+03	6.35E-04	2.66E+01	4.94E+00	7.85E-01	2.06E-02	5.95E+04
A5 Installation	2.83E+03	3.21E-04	8.42E+00	1.64E+00	2.38E+01	1.73E-02	3.65E+04
B1-5 Use, Maintenance, Repair, Replacement, Refurbishment	0	0	0	0	0	0	0
B6 Operational energy use	7.73E+05	9.20E-02	7.12E+03	4.18E+02	3.16E+02	1.18E-01	1.01E+07
B7 Operational water use	0	0	0	0	0	0	0
C1 De-construction/ Demolition	0	0	0	0	0	0	0
C2 Transport to end-of-life treatment	4.21E+03	6.41E-04	1.55E+01	2.97E+00	5.34E-01	3.41E-02	6.05E+04
C3 Waste processing	2.86E+04	1.67E-05	2.88E+00	6.43E-01	1.02E-01	3.77E-04	1.96E+03
C4 Disposal	0	0	0	0	0	0	0

# Approvals INSTAFLEX

## + LAND-BASED



**AENOR**  
Spanish Association for  
Standardisation and Certification

001/ 006238



**Global-Mark**  
Global-Mark Pty Ltd., Australia

GM-WM-040046-I02-R00  
GM-WM-040130-I02-R00



**BSi**  
British Standards Institution

KM 39698



**kiwa**  
Kiwa N.V., Netherlands

K48336/2  
K48341/02



**aTg (BCCA)**  
Belgian Construction Certification  
Association

05/ 1870



**ÖVGW**  
Österreichische Vereinigung für das  
Gas- und Wasserfach , Austria

W 1.119



**CSTB**  
Centre Scientifique et Technique du  
Bâtiment, France

109-1777  
167-1777



**SVGW**  
Schweizerische Verein des Gas- und  
Wasserfaches, Switzerland

8703-1961  
9403-3190



**ACS**  
Attestation de Conformité Sanitaire,  
France

LY 229  
NY 081



**VKF**  
Vereinigung Kantonalen Feuerversi-  
cherungen, Switzerland

Z 168819



**DVGW**  
Deutscher Verein des Gas- und  
Wasserfaches e.V., Germany

DW-8501AQ3144  
DW-8501BR0424  
DW-850-1AT2528



**WRAS**  
Water Regulation Advisory Scheme,  
England

1310511  
1310512



# Approvals INSTAFLEX

## + MARINE



**ABS**  
American Bureau of Shipping

14-GD1218536-PDA



**RINA**  
Royal Institution of Naval Architects,  
England

MAC375614CS



**DNV-GL**  
Det Norske Veritas- Germanischer  
Lloyd, Norway

74455-96HH



**BV**  
Bureau Veritas, France

35855/A0 BV



**LR**  
Lloyd's Register, England

12/00071(E3)



**CCS**  
China Classification Society

SH13G00019  
SH13G00020



**Class NK**  
Nippon Kaiki Kypokai, Japan

13008H



**RMROS**  
Russian Maritime Register of  
Shipping

15.40030.250

# Technical Data

## Pressure loss chart

### Pressure loss chart for INSTAFLEX PB pipes d16-d225

#### Pipe friction loss in relation to flow rate

#### Basis of calculation

Water temperature  $\vartheta_k = 10^\circ\text{C}$

Surface roughness  $k = 0.007 \text{ mm}$

Viscosity  $\nu = 0.00131 \text{ Pa}\cdot\text{s}$

Density  $\rho = 999.70 \text{ kg/m}^3$

#### Recommended flow velocity according SVGW guideline W3/2013

max. 4.0 m/s for single outlet lines

max. 3.0 m/s for apparatus lines

max. 3.0 m/s for floor distribution lines

max. 2.0 m/s for distribution lines

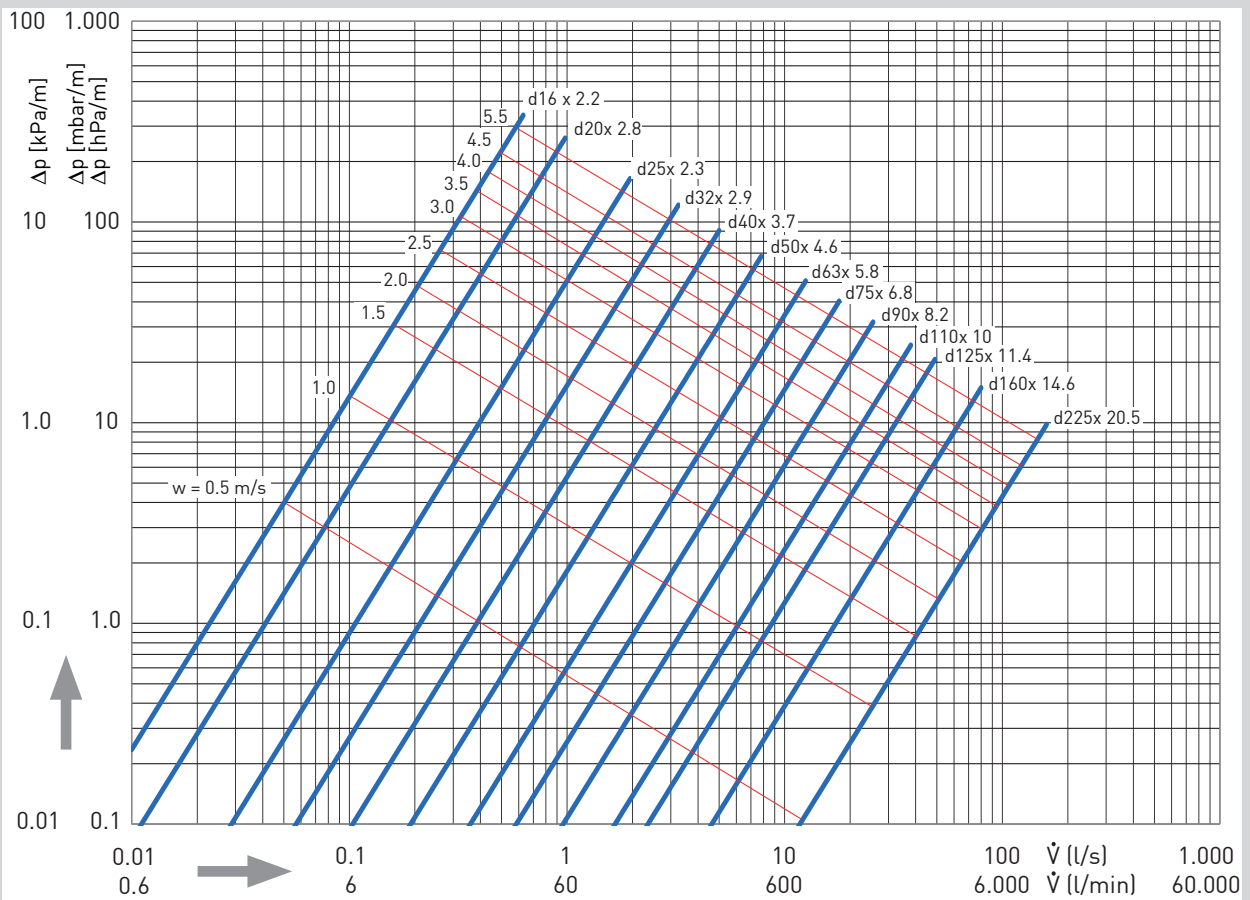

#### Correction factor values with different water temperatures / Facteurs de correction pour d'autres températures

#### Fattori di correzione per varie temperature

$\vartheta_w / (^\circ\text{C})$	10	20	30	40	50	60	70	80	90	95
f	1.000	0.955	0.915	0.870	0.835	0.805	0.775	0.753	0.737	0.730



# Technical Data

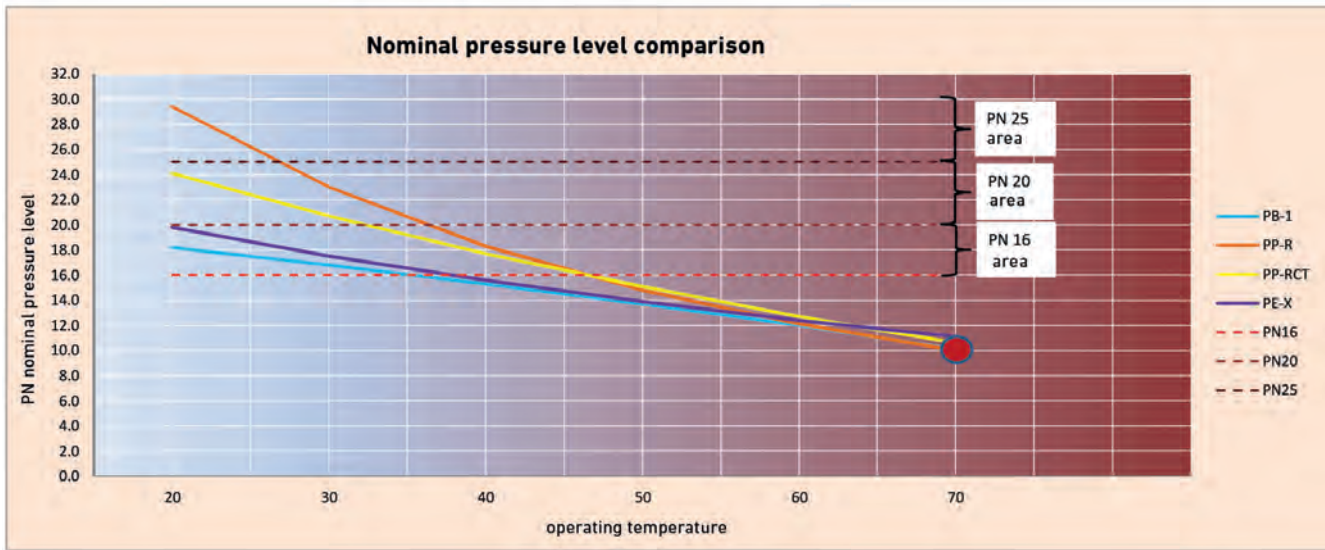

# Mobile Engineering Tools

For an individual and accurate engineering of your application please try our state-of-the-art engineering tools

## Planning Assistance

You plan – and we back you with our valuable expertise. Our customers enjoy support in many ways from detailed information on products, systems and materials to practical online calculation tools and personal assistance.

## Personal Support

Our tools and documents answer many questions, but maybe not all. Your contact in your local sales office will provide you with the support you need in order to find a solution to your specific problem.



GF Piping Systems  
Mobile Apps

# Technical Data

Temperature [°C]	Time [years]	Polybuten PB-1		
			Pipe series	
			5	11
approved range	10	1	20.3	
		5	20.1	
		10	20.0	
		25	19.7	
		50	19.4	
		100	19.1	
	20	1	19.3	
		5	19.1	
		10	18.9	
		25	18.5	
		50	18.2	
		100	17.8	
	30	1	18.2	
		5	17.9	
		10	17.6	
		25	17.2	
		50	16.8	
		100	16.5	
40	1	16.9		
	5	16.5		
	10	16.2		
	25	15.7		
	50	15.3		
	100	15.0		
50	1	15.5		
	5	15.0		
	10	14.6		
	25	14.1		
	50	13.7		
	100	13.4		
60	1	14.0		
	5	13.2		
	10	12.8		
	25	12.3		
	50	12.0		
	70	1	12.3	
5		11.3		
10		10.9		
25		10.5		
50		10.1		
calculated range		80	1	10.2
	5		9.3	
	10		8.9	
	12		8.8	
	18		8.6	
	25		8.4	
	90	1	7.9	
		4	7.2	
		5	7.1	
		6	7	
		10	6.7	
		15	6.5	
95	1	6.8		
	2.5	6.3		
	4	6		
	5	5.9		
	10	5.6		

**INSTAFLEX d16-d110**  
Working pressure (PN16)  
expected lifetime 20 years

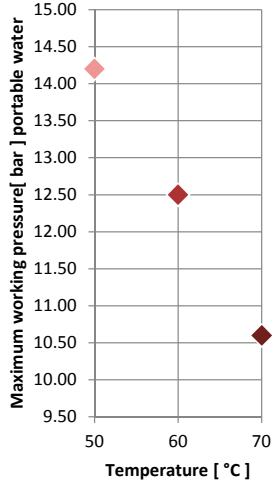

**INSTAFLEX d125-d225**  
Working pressure (PN10)  
expected lifetime 20 years

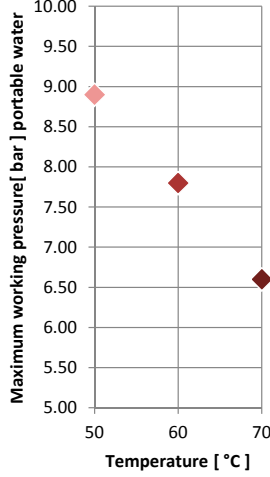

**INSTAFLEX d16-d110**  
Working pressure (PN16)  
expected lifetime 30 years

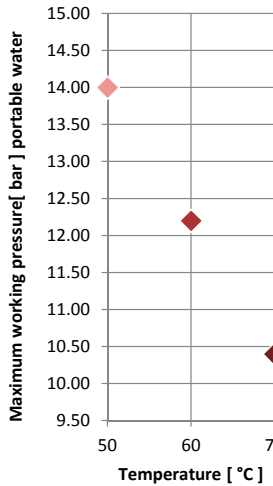

**INSTAFLEX d125-d225**  
Working pressure (PN10)  
expected lifetime 30 years

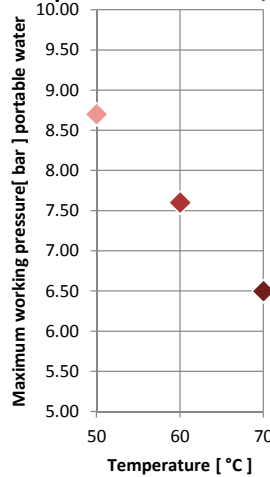

**INSTAFLEX d16-d110** Working  
pressure (PN16) expected  
lifetime 50 years

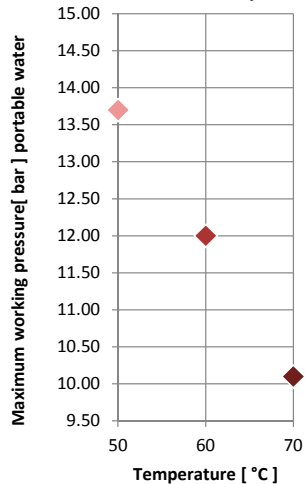

**INSTAFLEX d125-d225**  
Working pressure (PN10)  
expected lifetime 50 years

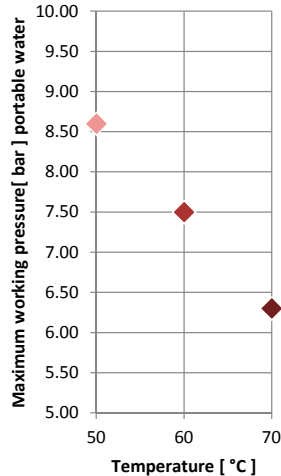

# Prefabrication Installation made easy

## Introduction

As an example for prefabrication we show you an easy method using the well known malleable cast iron fittings. This method can be used as well for plastic piping systems.

The z dimension installation method, developed by GF in conjunction with experienced installers of domestic and industrial piping systems, has been proving its worth for years in practical applications. The method offers a basis for efficient planning, preparation for work and preliminary assembly and can result in savings in time and effort:

- staff use can be reliably planned
- administrative work more easily completed
- calculation and costing simplified
- optimised machine use
- reduced storage requirement of own fittings and pipes
- optimisation of transportation the pipeline layout can easily be recognized by the pipeline diagram.

## z dimension

The z dimension – also called «laying length» is the middle distance between

- installed pipe end and the axis of the fitting or
- the ends of two installed pipes

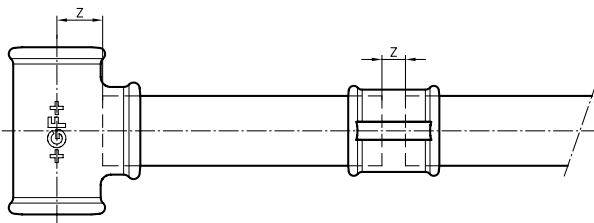

The z dimensions are calculated from the overall lengths less the average length of engagement. z dimensions were introduced by GF with a view to rational planning and preparation for work.

## Requirements

The z dimension method relies on:

- knowledge of the pipeline layout
- knowledge of the space requirements of valves, appliances and their locations.
- coordination with architect, planner, works management and the other businesses who work may have an influence on the pipeline layout.
- use of fittings with constant dimensional accuracy, such as GF's.
- Pipe threads conforming to standards, implying combined exact adjustment of the threading machine.

## z dimension and measurement procedure

z dimension and uniform measuring procedure are the core of the GF installation method.

The z dimension is the pipe installers «design dimension». With its help he can easily calculate the exact pipe length between fittings and/or valves. The principle of forms the basis for determining and using the z dimension.

standardised measuring centre - centre = M

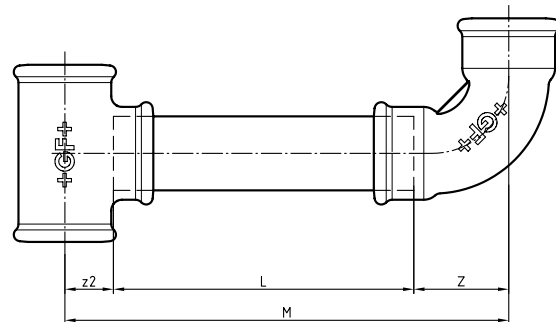

$$\text{Pipe length } L = M - (z2 + z)$$

# Prefabrication Installation made easy

The z dimension is calculated as the difference between «dimension face – middle» (a, b or c) and length of engagement of the pipe thread.

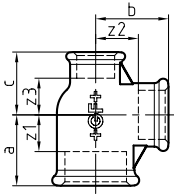

For fittings, e.g. tee no. 130, reduced branch and run:  
 $z1 = a$  - length of engagement  
 $z2 = b$  - length of engagement  
 $z3 = c$  - length of engagement

The fitting's bead deliberately put on the GF fittings can be used as a measuring aid.

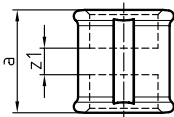

Exception – socket no. 270, 271:  
 $z1 = a - 2$  length of engagement

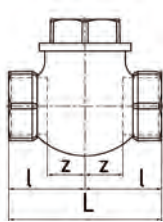

For valves:  
 $z = l$  - length of engagement  
 If the total overall length is indicated by L, the following applies:  
 $z = L/2$  - length of engagement

## Pipe threads

Another precondition for using the GF z dimension method is that the pipes are cut with the correct standardised threads. This assures that all pipes with the connecting pieces can be screwed together equally far and the dimensions M taken as a base are also correct after installation.

The pipe thread must be cut clean and to EN 10226-1 standard (or ISO 7-1 with a taper of 1:16). The taper pipe thread also produces a strengthening of the pipe residual wall in the second half of the thread. Unequal thread lengths influence the centre-centre dimension M and have a negative effect particularly for straight section with several branches.

### Note:

The centre-centre dimension (M) can show a permitted tolerance of  $\pm 1/2$  thread.

## Length of engagement

The nominal engagement length of the pipe external thread are (rounded values):

Joint size	Average length of engagement in mm
1/8	7
1/4	10
3/8	10
1/2	13
3/4	15
1	17
1 1/4	19
1 1/2	19
2	24
2 1/2	27
3	30
4	36

# Prefabrication Examples of use

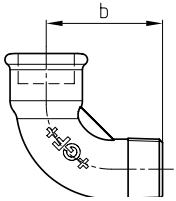

b is the distance of internal thread centre to face of the external thread.

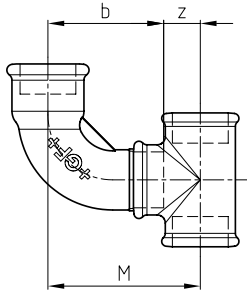

For fittings combinations with internal and external threads the sum of  $z + b$  produces the axial distance M:

$$M = z + b$$

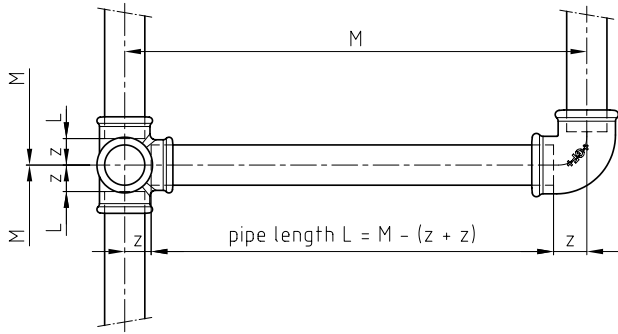

Principle of the z dimension installation method:  
uniform measuring centre - centre = M

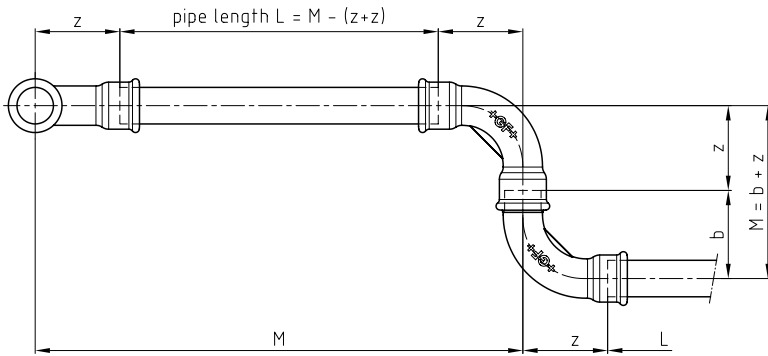

Exact pipe thread lengths produce exact M dimensions.

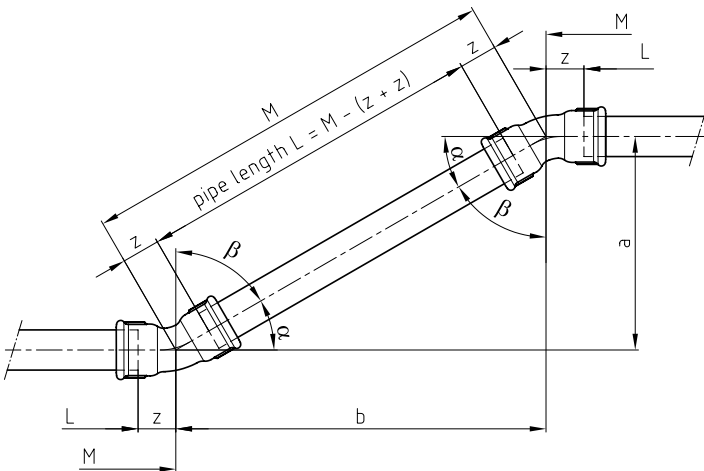

The M dimension for sloping pipe-line parts is easily calculated with the factor or numerical table.

# Calculation of the length of sloping pipelines

Parts of a pipeline diverging from the horizontal and verticals can only be accurately marked out in a few cases. Accurate results are obtained by rectangular measuring and determining the remaining (triangle) side lengths.

There are two possibilities for calculating the pipe lengths by means of the z dimensions:

## 1. Factor table

given:		a		b	
$\alpha$	$\beta$	Factor for		Factor for	
		b	c = M	a	c = M
75°	15°	0,268	1,035	3,732	3,864
60°	30°	0,577	1,155	1,732	2,000
45°	45°	1,000	1,414	1,000	1,414
30°	60°	1,732	2,000	0,577	1,155
15°	75°	3,732	3,864	0,268	1,035

$\alpha$  = given angle  
 $\beta$  = accompanying angle  
 angle-dependent factors multiplied with  
 the given dimension a or b = sought  
 dimensions b and c or a and c.

Example:

a = 28,5

$\alpha = 45^\circ$

$c = M = 28,5 \times 1,414$   
 $= 40,3$

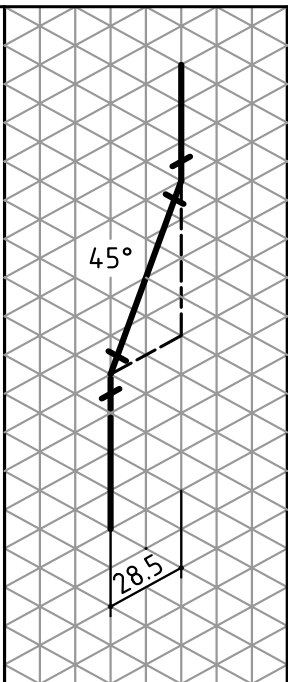

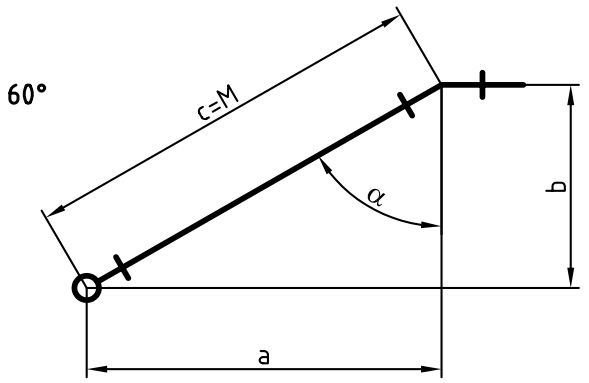
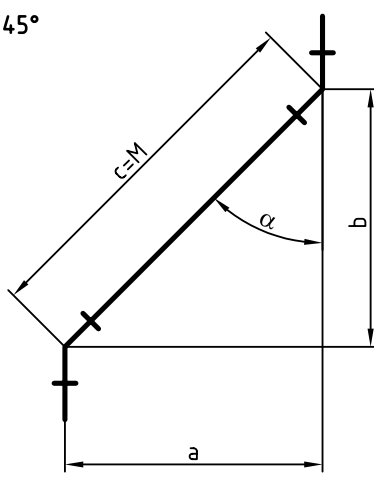
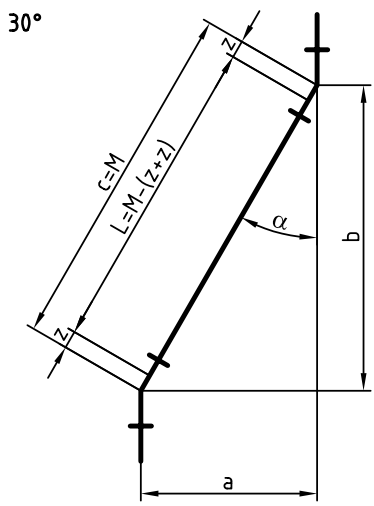

## 2. Numerical table

### Example:

Tier in a rising train of pipes. The dimensions M, M1 and a are taken on the site, the remainder are to be determined from the table.

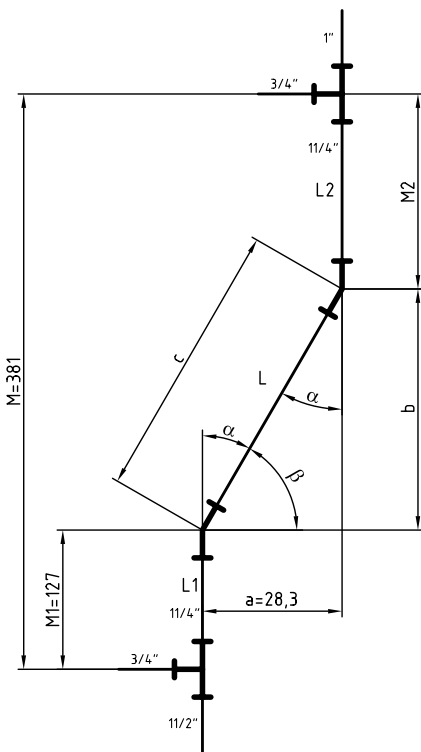

Planned fittings (from bottom to top):

- 1 tee no. 130 - 11/2 x 3/4 x 11/4
- 2 bends no. 51 - 11/4
- 1 tee no. 130 - 11/4 x 3/4 x 1

The projection a is 28.3 cm = 283 mm. 283 consists of 3 + 80 + 200. In columns b and c we find the partial values belonging to 3, 80 and 200 for the perpendiculars b and the slopes c.

In this case lengths b and c result from adding up the partial values  $\alpha = 30^\circ$ ,  $\beta = 60^\circ$ .

a (known)	b	c
3 mm	5,2 mm	6 mm
80 mm	138,6 mm	160 mm
200 mm	346,4 mm	400 mm
<b>283 mm</b>	<b>490,2 mm</b>	<b>566 mm</b>
or a=28,3 cm	b=49,0 cm	c= 56,6 cm

Pipe length  $L = c - (2 \times z \text{ dimension of bend no. 51} - 11/4)$

z dimension bend = 33 mm

$$L = 56.6 - (2 \times 3.3) = 56.6 - 6.6 = 50 \text{ cm}$$

Pipe length  $L1 = M1 - (\text{sum of the z dimension of tee piece no. 130} - 11/2 \times 3/4 \times 11/4 \text{ and bend no 51} - 11/4)$

z dimension tee no. 130 (on 11/4 exit) = 17 mm

z dimension bend = 33 mm

$$L1 = 127 - (1.7 + 3.3) = 127 - 5 = 122 \text{ cm}$$

$$M2 = M - (M1 + b), M1 = 127, b = 49$$

$$M2 = 381 - (127 + 49) = 381 - 176 = 205 \text{ cm}$$

Pipe length  $L2 = M2 - (\text{sum of the z dimensions of bend no. 51} - 11/4 \text{ and tee piece no. 130} - 11/4 \times 3/4 \times 1)$

z dimension bend = 33 mm

z dimension tee no. 130 (on the 11/4 exit) = 17 mm

z dimension tee no. 130 (on the 11/4 exit) = 17 mm

$$L2 = 205 - (3.3 + 1.7) = 205 - 5 = 200 \text{ cm}$$

# Clear outlining of the pipework

The isometric diagrams of pipes and horizontal projections are ideal for quick preparation when using the GF installation method.

The drawing of the pipework should be given in a simple but effective way. The diagrams can be sketched by the installer himself on the spot.

This type of representation enables quick outlining with no aids such as ruler, set square etc. either directly on the site of installation or according to a plan. The pipework system to be installed is always clearly recognisable with all necessary fittings, valves etc.

The 30° pipeline diagram (3D plan) is intentionally not drawn to scale, i.e. long pipe sections are made shorter, short pipe sections are to a large extent made somewhat longer. In this way even extensive pipe systems can be represented on an A4 sheet of paper.

Pipelines running at right angles to each other are drawn as shown below:

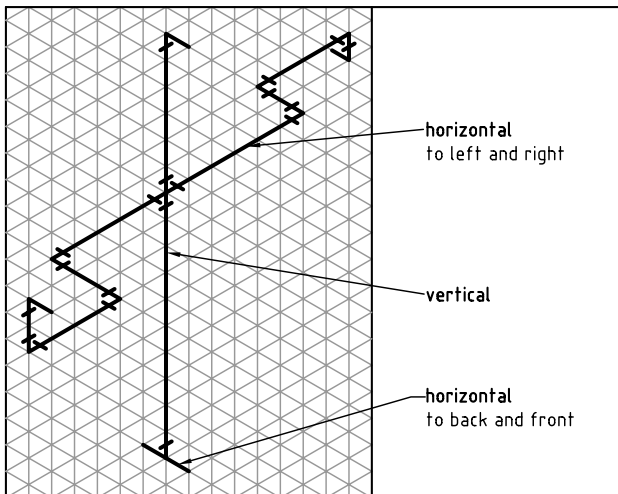

Pipelines sloping in relation to each other are drawn as shown in the example below:

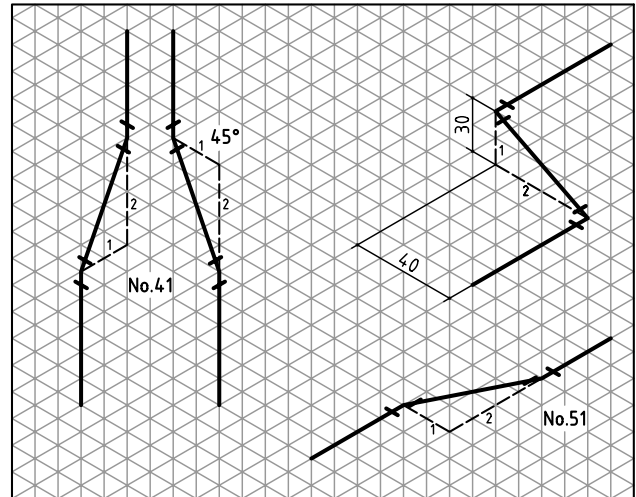

Changes of direction are shown in the ratio of 2:1 or 1:2 irrespective of angles and dimensions. By drawing in the triangle as an aid the change of direction is set accurately. The divergence is established by giving the type of fitting (catalogue no. or angle) or by dimensioning.

Fittings and/or jointing points can be marked with a small dash, valves with the standardized symbols.



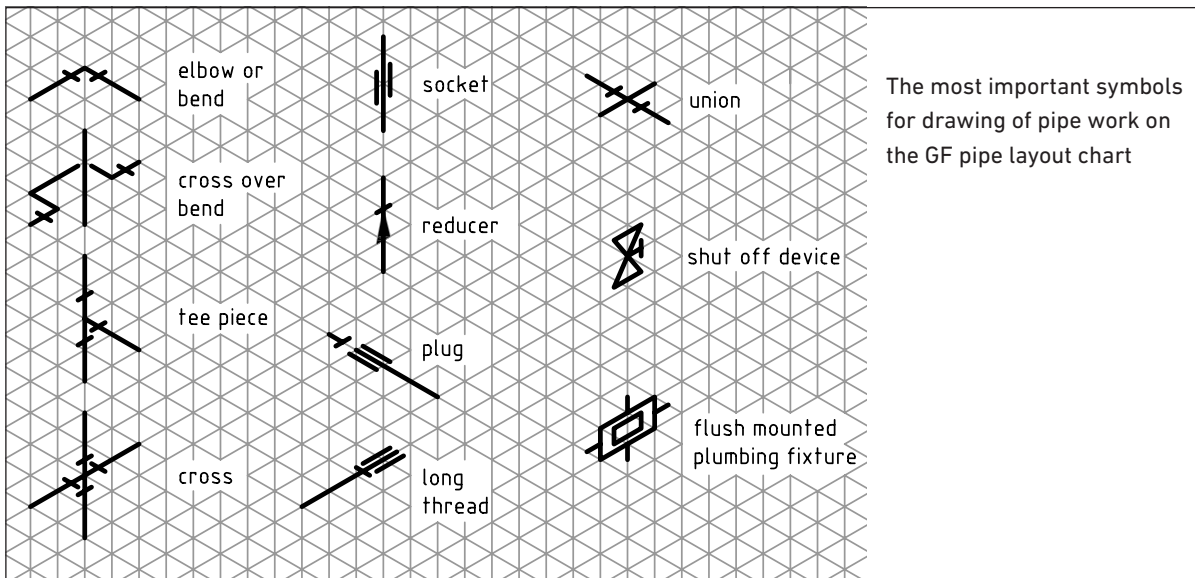

### The GF pipe layout chart

The 30° pipeline diagram can be drawn on the GF pipe layout chart, for example. The oblong format selected is particularly suitable for use on the site. The area available for sketching, either allows sections of pipelines to be portrayed, or even more extensive part installations (e.g. cellar quantization, floor distributors) to be reproduced.

The advantages of the GF pipe layout chart are obvious:

- division of the installation work
- quick drawing of the pipework diagram
- clear record of the centre - centre dimensions
- very simple pipe length calculation
- basis for a summary of pipe components
- costing document
- thus offering real rationalisation:
- measure, mark, cut into lengths and cut the thread for all pipes of the same diameter one after the other.
- If the project documents are saved, the pipe layout chart makes it possible to determine the pipeline layout exactly even years later. Extensions or repairs can be carried out considerably more easily.

+GF+ GEORG FISCHER PIPING SYSTEMS		Pipe layout chart for z dimension method			Item	dimension M-M in cm	z dimensions in cm	pipe length in cm	incl. dimension	
Site:	KRENN & Co., Technischiedlung II, 3160 TRAISEN	Date	No. of pages	Page No.	1	26.0	10.2	15.2	1	CW
		16.02.04	4	1	2	21.2	6.8	14.4	1	CW
					3	21.0	5.5	15.5	1	CW
					4	7.3	-	130/12	1	CW
					5	44.0	3.6	40.4	1	CW
					6	62.0	5.5	56.5	3/4	CW
					7	15.0	5.5	9.5	3/4	CW
					8	48.0	3.0	45.0	3/4	CW
					9	42.0	3.0	39.0	1/2	CW
					10	205.0	3.0	202.0	1/2	CW
					11	60.0	3.0	57.0	1/2	CW
					12	5.5	-	130/12	1/2	CW
					13	5.5	-	130/12	1/2	CW
					14	62.0	3.6	58.4	1/2	CW
					15	51.3	3.0	48.3	1/2	HW
					16	10.0	4.7	5.3	1/2	HW
					17	62.0	4.7	57.3	1/2	HW
					18	48.0	3.0	45.0	1/2	HW
					19	57.0	3.0	54.0	1/2	HW
					20	110.0	3.0	107.0	1/2	HW
					21	41.3	3.0	38.3	1/2	HW
					22	5.2	-	130/12	1/2	HW
					23	16.2	3.0	13.2	1/2	HW

# Prefabrication

## Practical conclusions

The GF z dimension installation method is the tried and tested basis for the skilled worker and industrial prefabrication of pipework installations.

Its objective is to bring together the same repetitive production sequences to achieve a trouble-free flow of materials and work, to avoid idle time, minimise setting up time and doing the same work twice and provide the optimal solutions.

This calls for:

- division of the pipework systems in installation sections.
- division of production in pre-assembly (in the workshop or on site) and installation. It is advantageous to prepare as large a number of the installations as possible in the workshop.
- summarised record of all important site dimensions, to be able to carry out in series prefabrication.

A main rule for this:

Gather as many pipework sections as possible from the planning documents.

However, where sections must be decided on the spot (offsetting of variations in the dimensions of the solidium) the following applies:

Always measure where pipelines are to be laid.

The GF z dimension method enables:

- in series prefabrication
- rational use of material, skilled labour and machines
- reduction of installation times
- adaptability to building progress
- very large independence from building deadlines
- better preliminary conditions for carrying out non-local items
- better preliminary conditions for carrying out refurbishment work
- more accurate work with lower expenditure
- consistent quality

As a result of these advantages, installation planning, starting with the preliminary draft, should be included in the building plan. A prerequisite of the rational running of building work is completed, co-ordinated planning of the implementation of work at its outset in its basic details.



Pipe layout chart for z dimension method

Site:

Date:





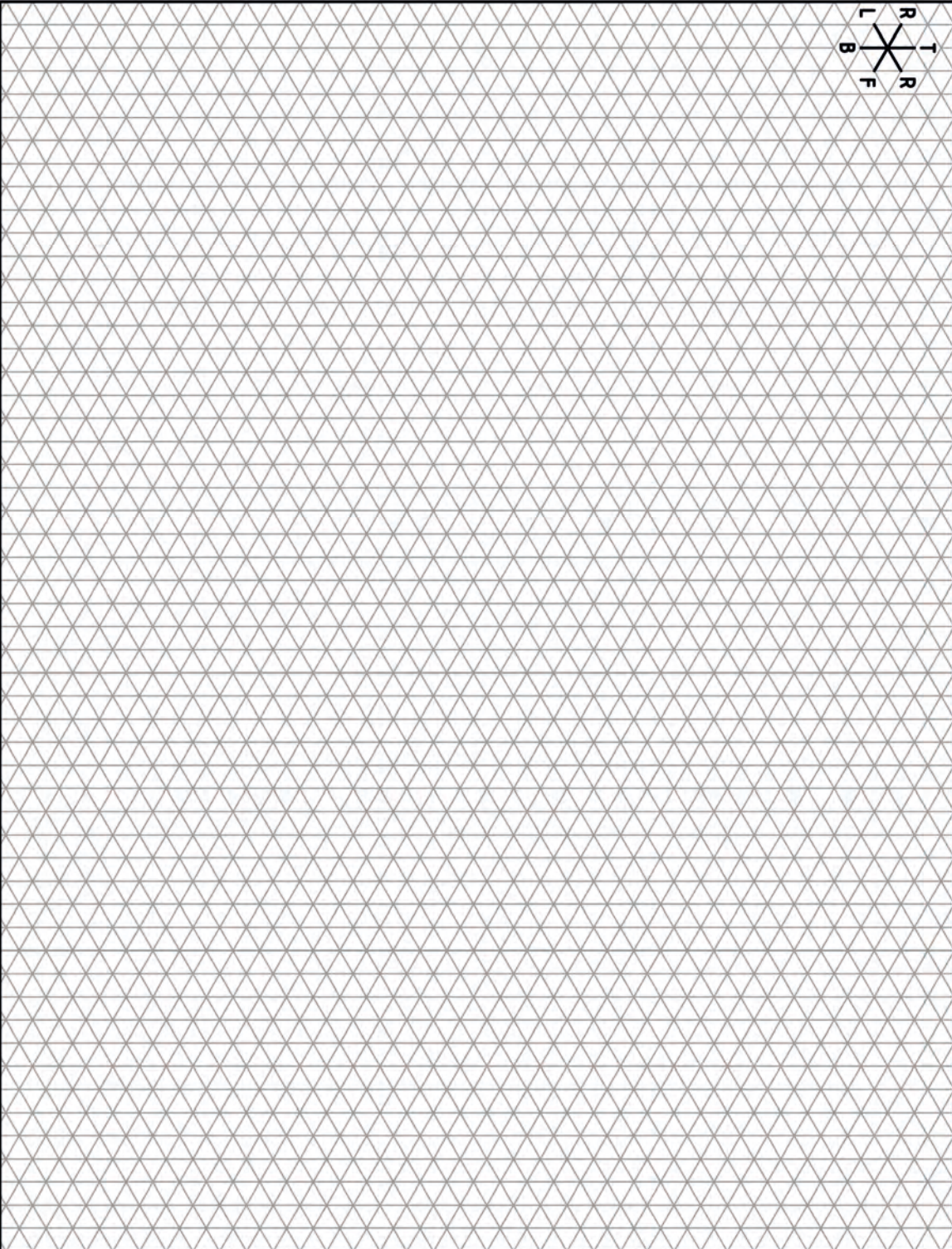





No. of pages:

Page No.:



item
dimension M-M in cm
z dimensions in cm
pipe length in cm
inch dimension



	Pipes	34
	Valves	44
	System adapters	64
	Pipe outlets	74
	Electro fusion jointing HWS	80
	Socket fusion jointing HMS	102
	Butt fusion	116
	Compression jointing	120
	Machines and tools	132
	Seminar- and training documents / samples	147

# INSTAFLEX

**Pipes**  
**Pipe support**





Pipes

37



Accessories / Pipe support

38



# Working with INSTAFLEX

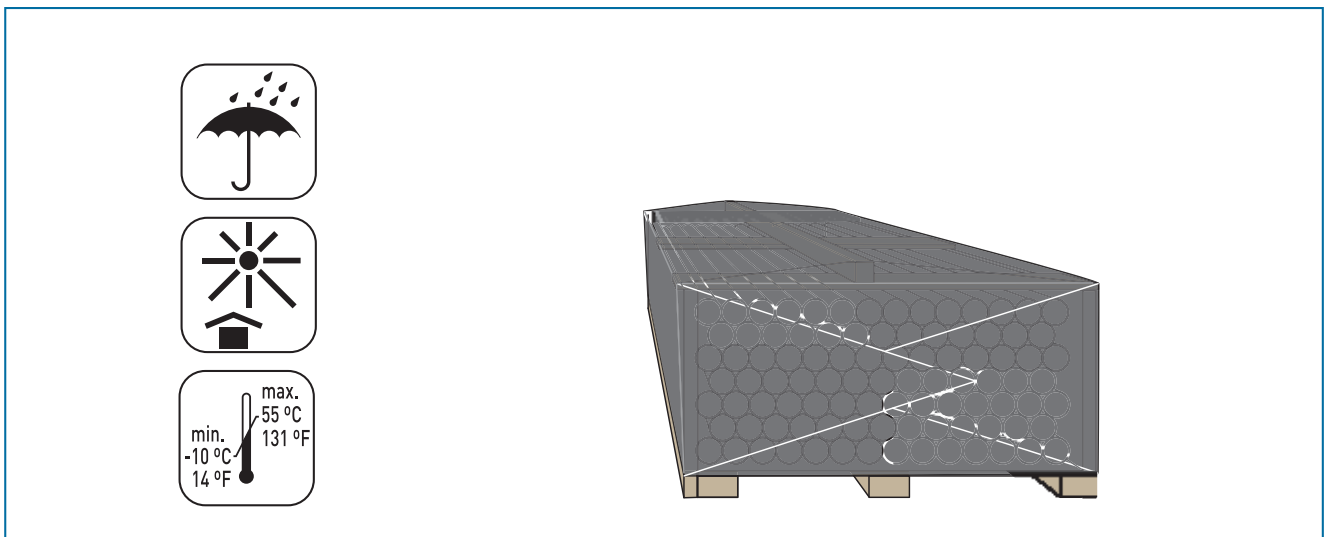
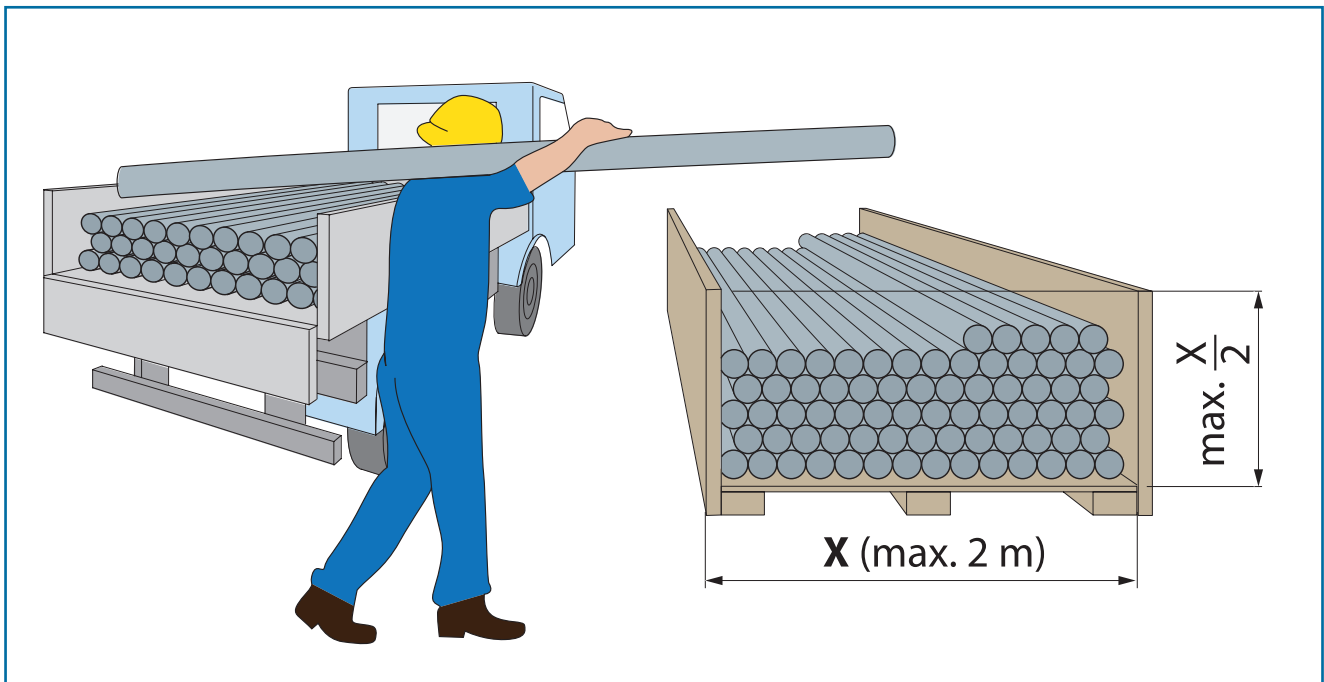
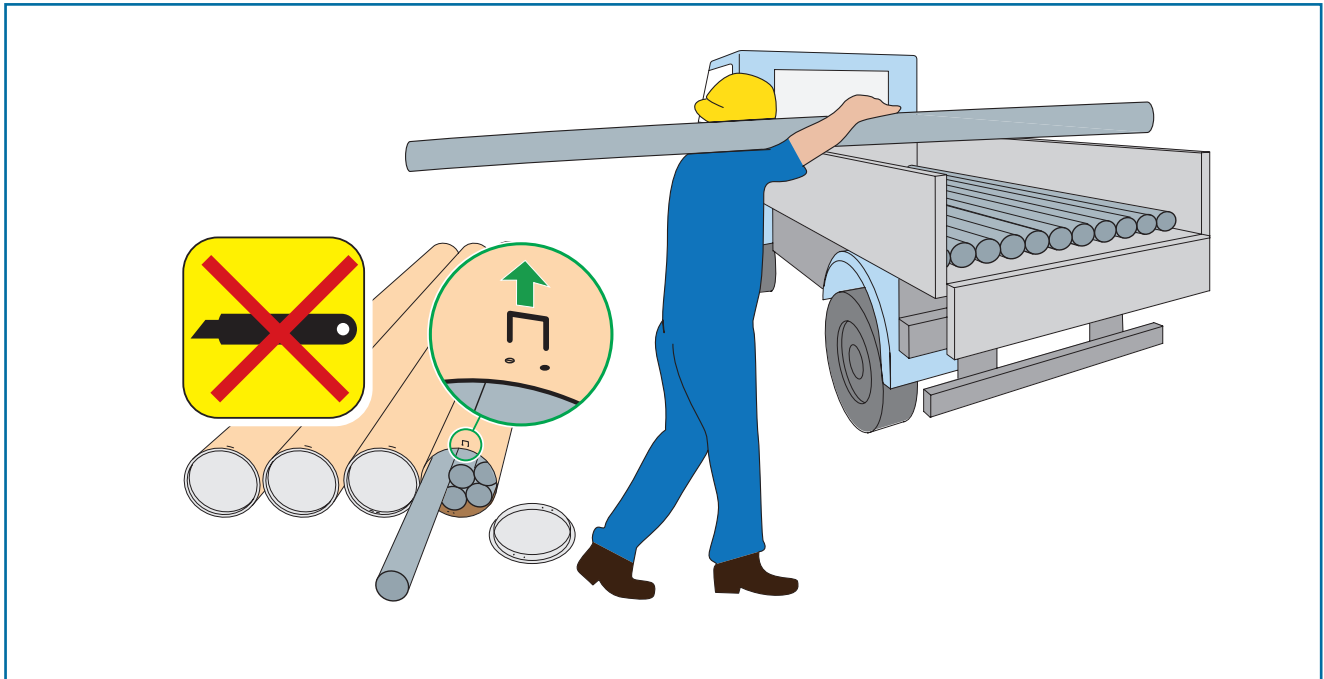



# Pipes



## PB pipe 5,8 m - bars

Packed in cardboard boxes / PN 16

d (mm)	s (mm)	Code	SP	Weight (kg)
16	2.2	<b>760 856 606</b>	52	0.097
20	2.8	<b>760 856 607</b>	52	0.151
25	2.3	<b>760 856 608</b>	58	0.165
32	2.9	<b>760 856 609</b>	23	0.270
40	3.7	<b>760 856 610</b>	17	0.416
50	4.6	<b>760 856 611</b>	17	0.645
63	5.8	<b>760 856 612</b>	6	1.020
75	6.8	<b>760 856 613</b>	6	1.440
90	8.2	<b>760 856 614</b>	6	2.060
110	10.0	<b>760 856 615</b>	6	3.050



## PB pipe 5.8 m - bars

Packed in PE-Bag / PN 16

d (mm)	s (mm)	Code	SP	Weight (kg)	Length (m)
125	11.4	<b>761 065 290</b>	6	3.950	5.8
160	14.6	<b>761 065 291</b>	6	6.460	5.8
225	20.5	<b>761 065 292</b>	6	12.700	5.8



## PB pipe (coiled)

Packed in cardboard boxes  
Packed in protective wrap

d (mm)	s (mm)	Length (m)	Code	SP	Weight (kg/m)
16	2.2	60	<b>760 853 389</b>	60	0.000
16	2.2	102	<b>760 853 395</b>	102	15.300
16	2.2	400	<b>760 856 624</b>	400	0.000
20	2.8	60	<b>760 853 390</b>	60	0.000
20	2.8	102	<b>760 853 397</b>	102	15.300
20	2.8	400	<b>760 853 398</b>	400	60.000
25	2.3	30	<b>760 854 946</b>	30	0.000



## PB pipe in protective pipe (coiled)

Packed in cardboard boxes

d (mm)	s (mm)	Code	SP	Weight (kg)	D (mm)
16	2.2	<b>760 853 387</b>	60	0.162	25
20	2.8	<b>760 853 388</b>	60	0.235	30
25	2.3	<b>760 854 910</b>	30	0.284	34

## Accessories / Pipe support

### Pipe transfer piece d16 / d20



d (mm)	Code	SP	Weight (kg)	L (mm)	H (mm)
16 - 20	<b>760 853 299</b>	30	0.116	45	40

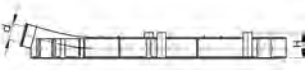

### Pipe transfer bend d16 / d20



d (mm)	Code	SP	Weight (kg)	L1 (mm)	H (mm)
16 - 20	<b>760 853 300</b>	18	0.113	45	180

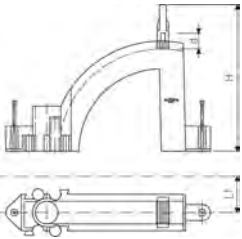

### Pipe support d16 / d20



d (mm)	Code	SP	Weight (kg)	L (mm)	L1 (mm)	H (mm)	H1 (mm)
16 - 20	<b>760 853 399</b>	12	0.269	90	45	235	70

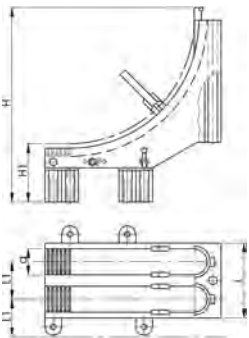

### Cap for protective pipe



d (mm)	Colors	Code	SP	Weight (kg)	D (mm)	L (mm)
16	red	<b>762 101 234</b>	10	0.006	25	70
16	blue	<b>762 101 235</b>	10	0.005	25	70
20	red	<b>762 101 236</b>	10	0.006	30	70
20	blue	<b>762 101 237</b>	10	0.005	30	70
20	red	<b>760 854 988</b>	10	0.005	30	70
20	blue	<b>760 854 989</b>	10	0.006	30	70





### Cap for protective pipe

d (mm)	Colors	Code	SP	Weight (kg)	D (mm)	L (mm)
16	red	<b>760 854 986</b>	10	0.005	25	70
16	blue	<b>762 101 235</b>	10	0.005	25	70
20	red	<b>760 854 988</b>	10	0.005	30	70
20	green	<b>760 854 989</b>	10	0.006	30	70

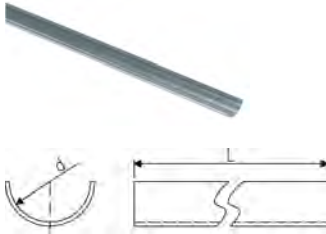

### Clip pipe support tray

d (mm)	Code	SP	Weight (kg)	L (mm)
16	<b>760 856 602</b>	30	0.550	3000
20	<b>760 856 603</b>	30	0.680	3000
25	<b>760 856 604</b>	30	0.844	3000
32	<b>760 856 605</b>	30	1.073	3000

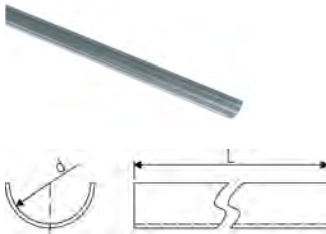

### Pipe support tray

For diameter over d90 no pipe support is required

d (mm)	Code	SP	Weight (kg)	L (mm)
40	<b>760 854 928</b>	30	1.335	3000
50	<b>760 854 929</b>	30	1.662	3000
63	<b>760 854 930</b>	30	0.570	3000
75	<b>760 854 985</b>	30	2.480	3000

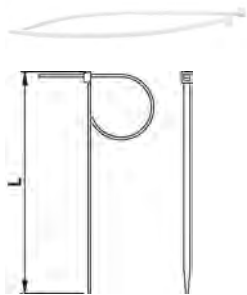

### Pipe binder

d-d (mm)	Code	SP	Weight (kg)	L (mm)
16 - 40	<b>760 853 283</b>	100	0.000	200
50 - 75	<b>760 853 284</b>	100	0.001	300
90 - 110	<b>760 854 984</b>	100	0.003	430



### Coupling for protective pipe

For pipe transfer piece 3891  
From the INSTAFLEX range  
\* available as long as stock exist

d (mm)	Code	SP	Weight (kg)
* 16	<b>760 853 316</b>	9	0.009
* 20	<b>760 853 753</b>	9	0.010

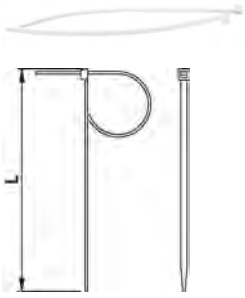

### Pipe binder

d-d (mm)	Code	SP	Weight (kg)	L (mm)
16 - 40	<b>760 853 283</b>	100	0.000	200
50 - 75	<b>760 853 284</b>	100	0.001	300
90 - 110	<b>760 854 984</b>	100	0.003	430



### Fawa pipe support

d (mm)	Code	SP	Weight (kg)
16 - 20	<b>760 853 278</b>	50	0.102



### Pipe support d16 / d20

d (mm)	Code	SP	Weight (kg)	L (mm)	L1 (mm)	H (mm)	H1 (mm)
16 - 20	<b>760 853 399</b>	12	0.269	90	45	235	70

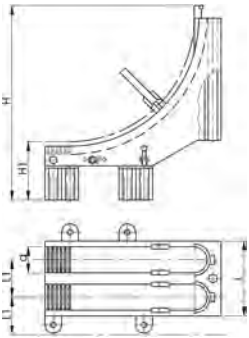

### Insta Pipe support d16 / d20

From the INSTAFLEX range

d (mm)	Code	SP	Weight (kg)	L (mm)	L1 (mm)	H (mm)	H1 (mm)
16 - 20	<b>760 853 399</b>	12	0.269	90	45	235	70

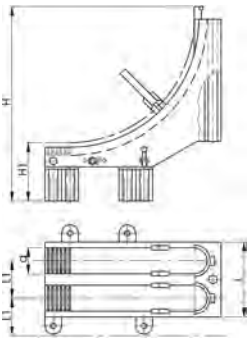



### Pipe transfer bend d16 / d20

d (mm)	Code	SP	Weight (kg)	L1 (mm)	H (mm)
16 - 20	<b>760 853 300</b>	18	0.113	45	180

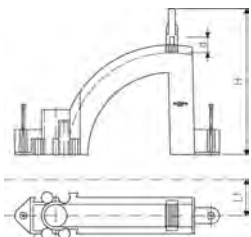

### Pipe transfer piece d16 / d20



d (mm)	Code	SP	Weight (kg)	L (mm)	H (mm)
16 - 20	<b>760 853 299</b>	30	0.116	45	40

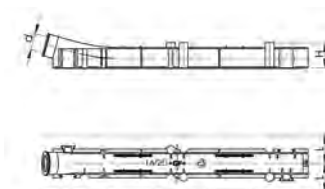

### Single Pipe clip, metal

d / outside protective pipe

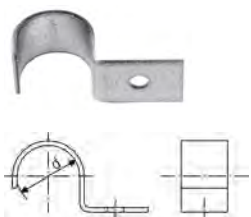

d (mm)	d1 (mm)	Code	SP	Weight (kg)
25	16	<b>760 853 254</b>	50	0.025
30	20	<b>760 853 567</b>	50	0.029
35	25	<b>760 854 951</b>	50	0.029

### Single Pipe clip - plastic

d / outside protective pipe



d (mm)	d1 (mm)	Code	SP	Weight (kg)
25	16	<b>760 853 627</b>	50	0.007

### Single pipe clip - metal

d / outside protective pipe

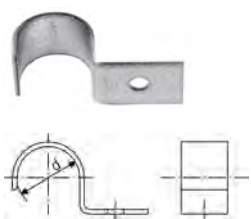

d (mm)	d1 (mm)	Code	SP	Weight (kg)
25	16	<b>760 853 254</b>	50	0.025
30	20	<b>760 853 567</b>	50	0.029
35	25	<b>760 854 951</b>	50	0.029



### Double pipe clip - metal

d (mm)	d1 (mm)	Code	SP	Weight (kg)
25	16	<b>760 853 628</b>	50	0.040



### Pipe clamp

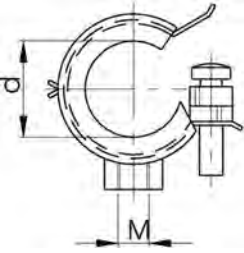

d (mm)	Code	SP	Weight (kg)	M (mm)
16	<b>761 066 296</b>	50	0.039	8
20	<b>761 066 297</b>	50	0.045	8
25	<b>761 066 298</b>	50	0.053	8
32	<b>761 066 299</b>	50	0.046	8
40	<b>761 066 300</b>	50	0.071	8
50	<b>761 066 301</b>	50	0.087	8
63	<b>761 066 302</b>	10	0.134	8
75	<b>761 066 303</b>	10	0.135	8
90	<b>761 066 304</b>	10	0.156	10
110	<b>761 066 305</b>	25	0.228	10



### KLIP-IT pipe clip type 061 PE metric

#### Model:

- Material: clip PE and safety clip PP black, bolts galvanized
- **Minimum order quantity: standard packaging SP**
- Height not designed for ball valve 546 and 543. Please use spacer 73 06 11.

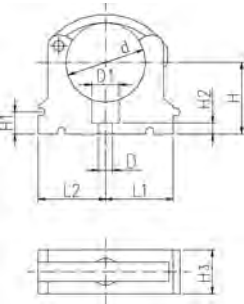

d (mm)	Code	SP	Weight (kg)	D (mm)	D1 (mm)	L1 (mm)	L2 (mm)	H (mm)	H1 (mm)	H2 (mm)	H3 (mm)	SC
* 16	<b>173 061 005</b>	10	0.006	6	11	14	17	23	10	6	16	M5
* 20	<b>173 061 006</b>	10	0.007	6	11	17	19	25	10	6	16	M5
* 25	<b>173 061 007</b>	10	0.009	6	11	19	22	28	10	6	16	M5
* 32	<b>173 061 008</b>	10	0.011	6	11	24	27	31	10	6	16	M5
40	<b>173 061 009</b>	10	0.026	7	14	34	34	35	10	7	22	M6
50	<b>173 061 010</b>	10	0.028	7	14	37	37	40	10	7	22	M6
63	<b>173 061 011</b>	10	0.047	9	17	45	45	52	10	10	25	M8
75	<b>173 061 012</b>	10	0.061	9	17	52	52	58	10	10	25	M8
90	<b>173 061 013</b>	10	0.098	9	17	65	65	65	10	10	28	M8
110	<b>173 061 014</b>	10	0.125	9	17	79	79	75	10	10	28	M8

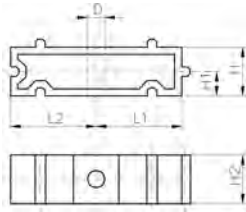

## KLIP-IT spacer type 061 PE

### Model:

- **Minimum order quantity: standard packaging SP**
- For pipe clips type 061, PE black, UV resistant

d	Inch	Code	SP	Weight	D	L1	L2	H	H1	H2	SC
(mm)	(inch)			(kg)	(mm)	(mm)	(mm)	(mm)	(mm)	(mm)	
16	3/8	<b>173 061 155</b>	10	0.005	6	14	17	20	10	16	M5
20	1/2	<b>173 061 156</b>	10	0.005	6	17	19	20	10	16	M5
25	3/4	<b>173 061 157</b>	10	0.006	6	19	22	20	10	16	M5
32	1	<b>173 061 158</b>	10	0.008	6	24	27	20	10	16	M5
40	1 1/4	<b>173 061 159</b>	10	0.016	7	34	34	20	10	22	M6
50	1 1/2	<b>173 061 160</b>	10	0.017	7	37	37	20	10	22	M6
63	2	<b>173 061 161</b>	10	0.025	9	45	45	20	10	25	M8
75	2 1/2	<b>173 061 162</b>	10	0.027	9	52	52	20	10	25	M8
90	3	<b>173 061 163</b>	10	0.040	9	65	65	20	10	28	M8
110	4	<b>173 061 164</b>	10	0.050	9	79	79	20	10	28	M8

# INSTAFLEX

## Valves







PB-valves

50



Spare parts - Retrofit top

53



Ball valves

55



Butterfly valves

58



Additional components

60

OLD

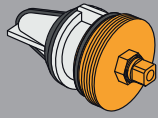

ø 20 / 25 / 32

NEW

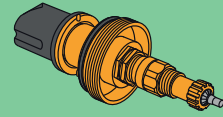

**WARNING**  
SHUT OFF WATER BEFORE  
WORK

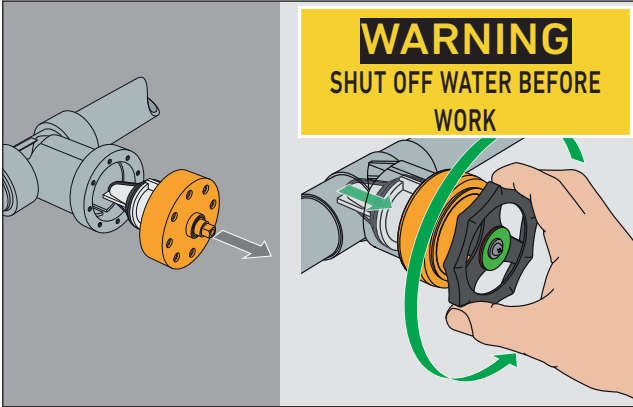

1

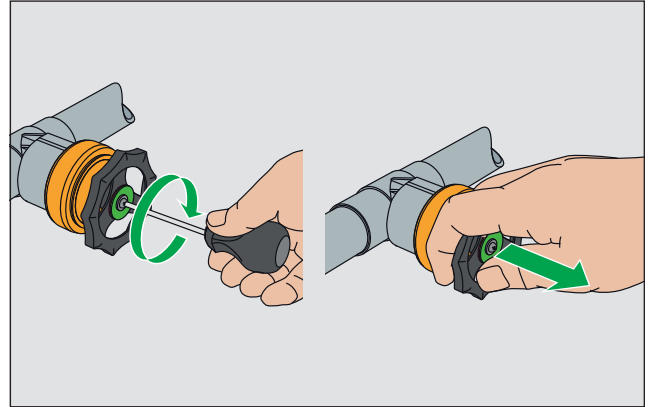

2

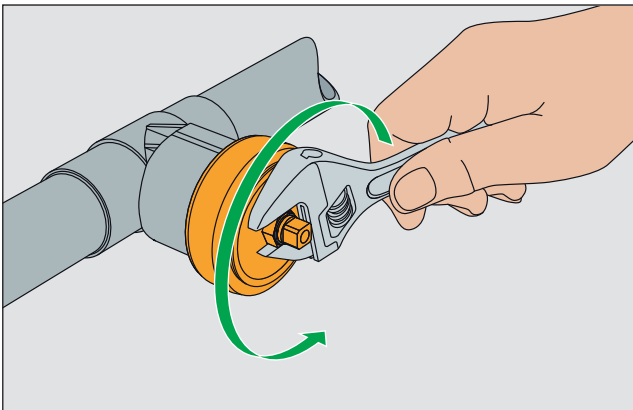

3

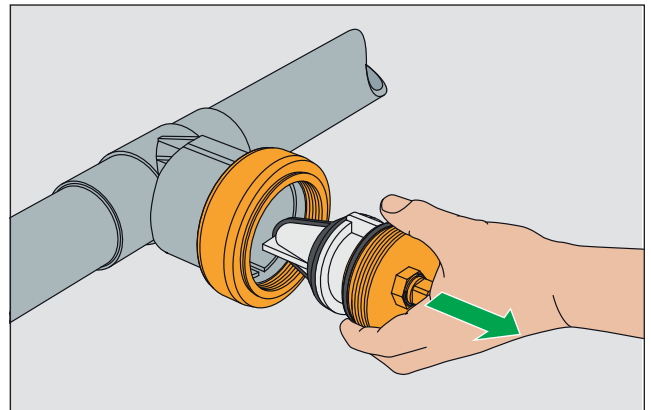

4

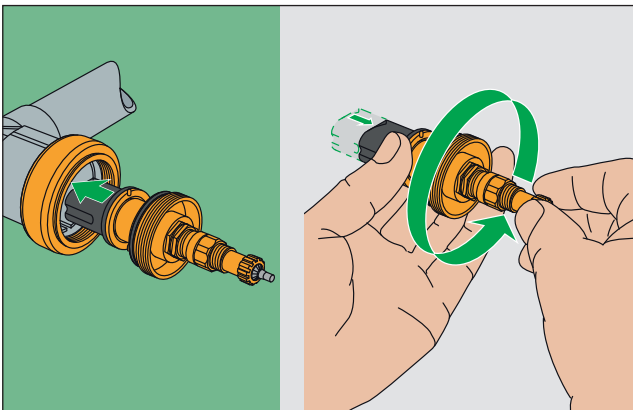

5

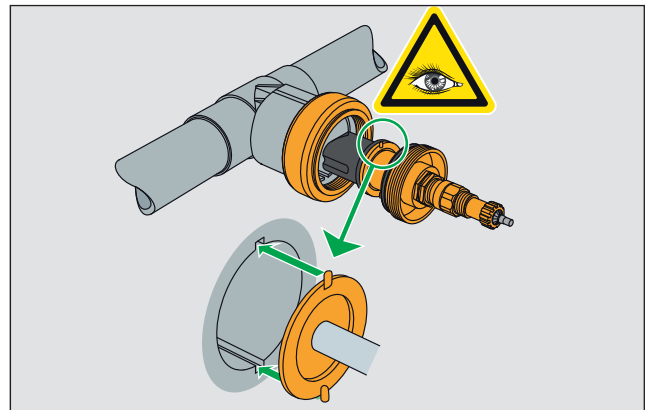

6

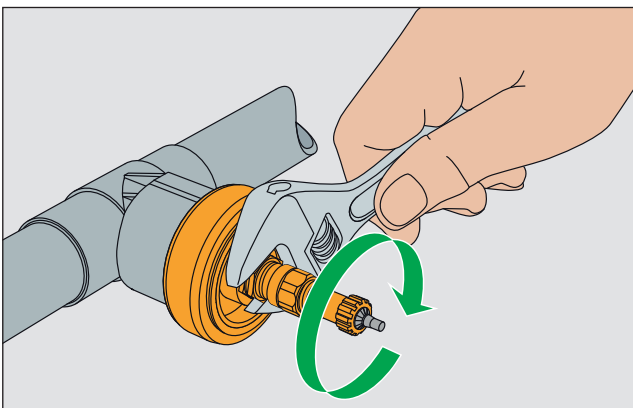

7

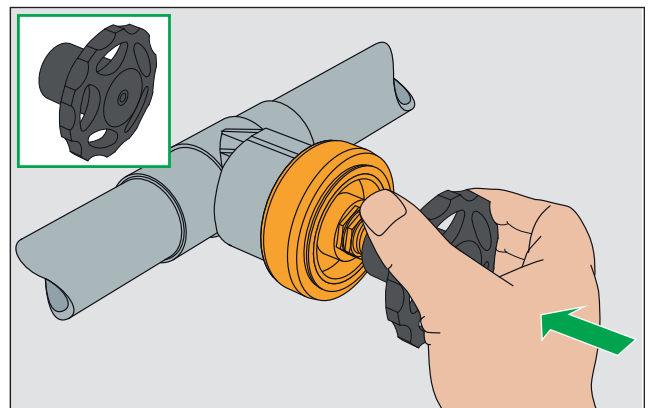

8

OLD

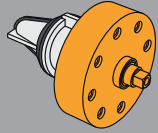

ø 40 / 50 / 63

NEW

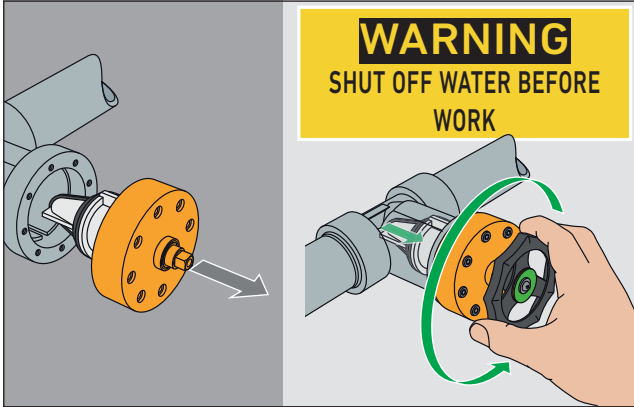
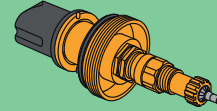

1

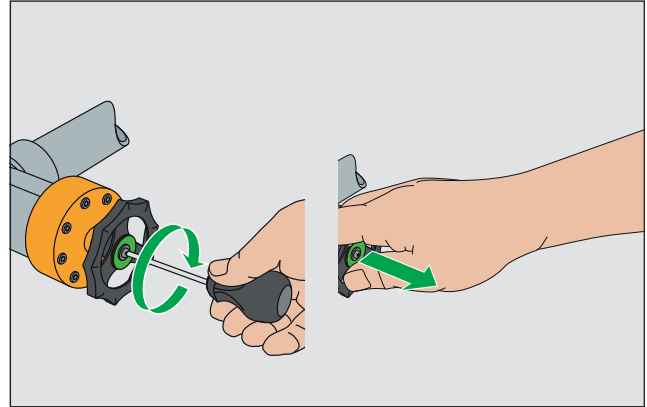

2

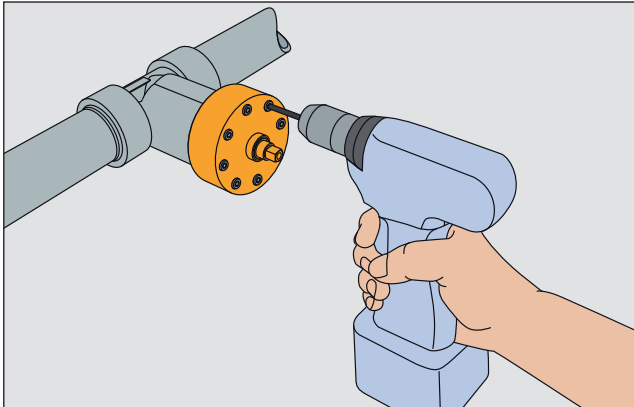

3

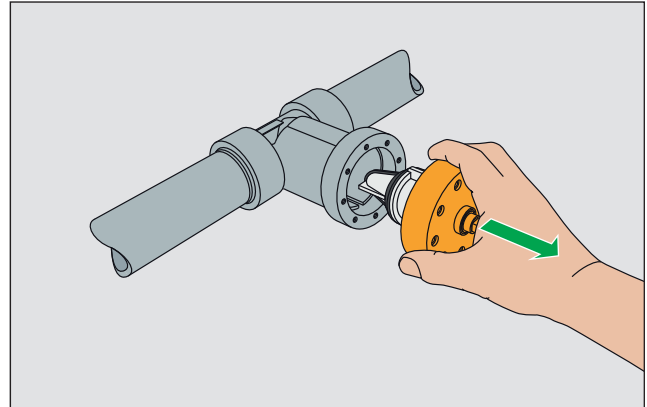

4

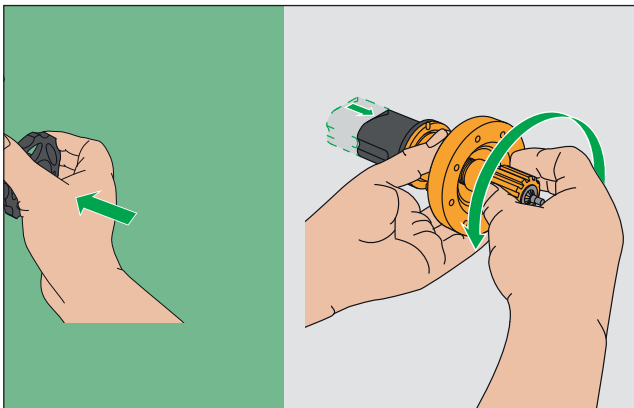

5

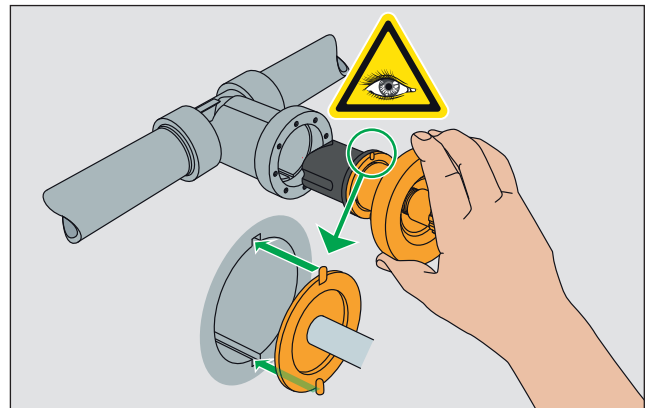

6

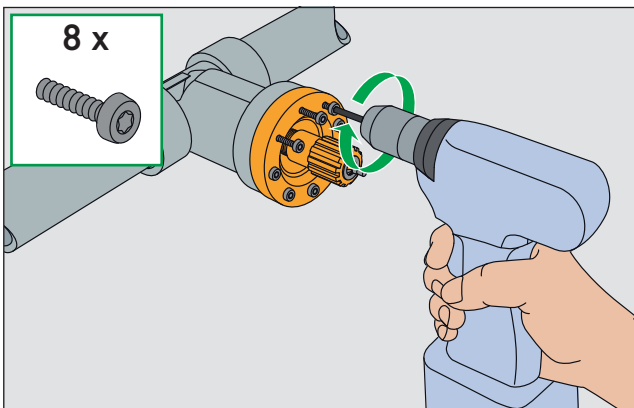

7

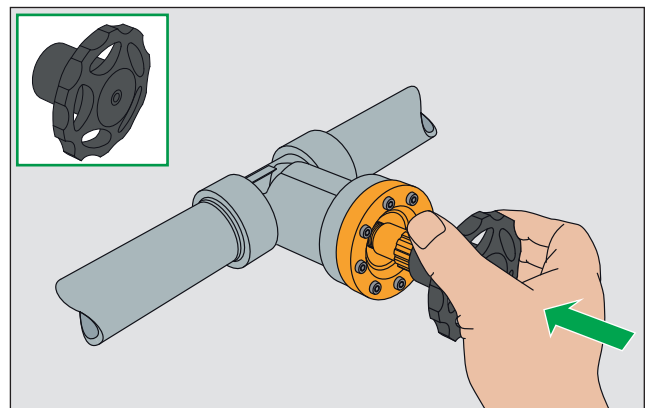

8

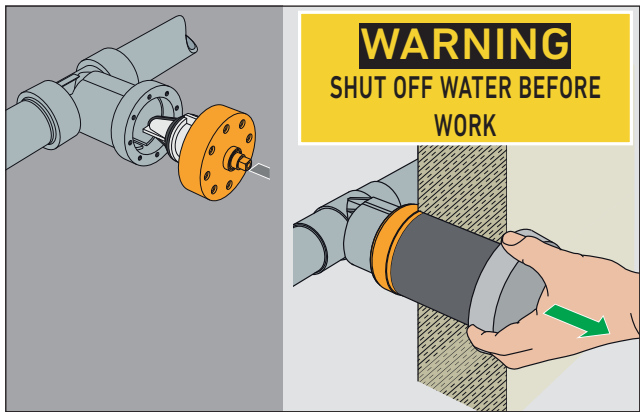

**1**

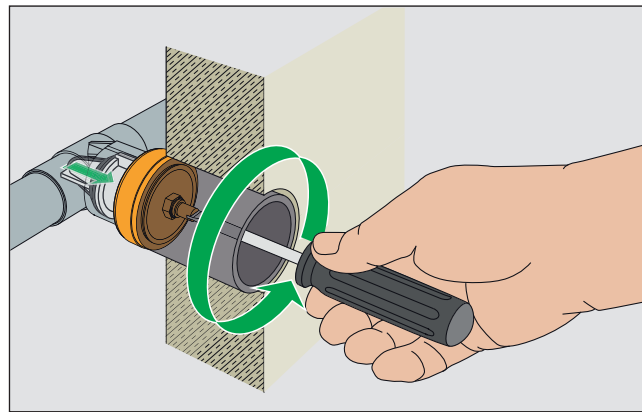

**2**

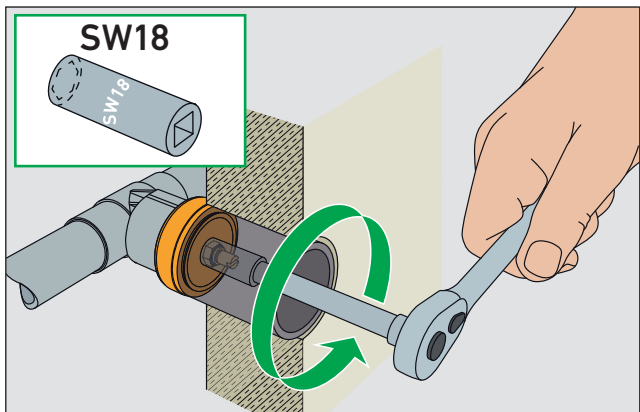

**3**

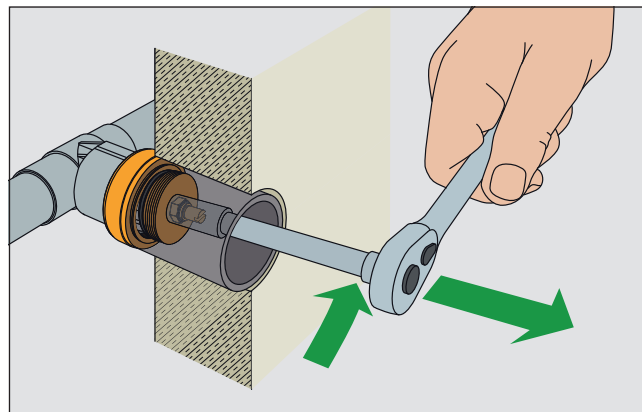

**4**

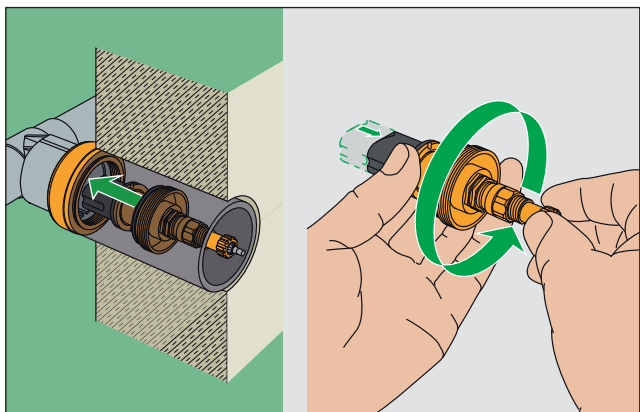

**5**

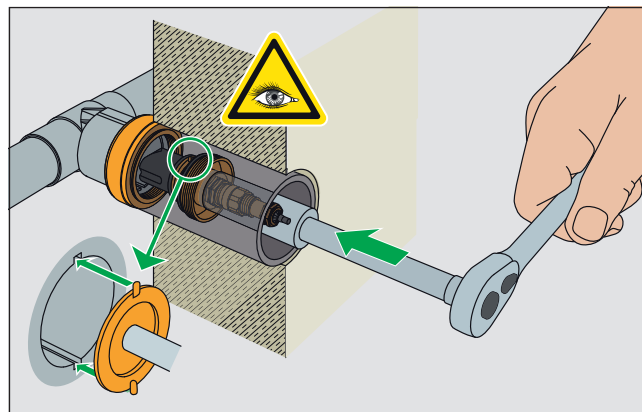

**6**

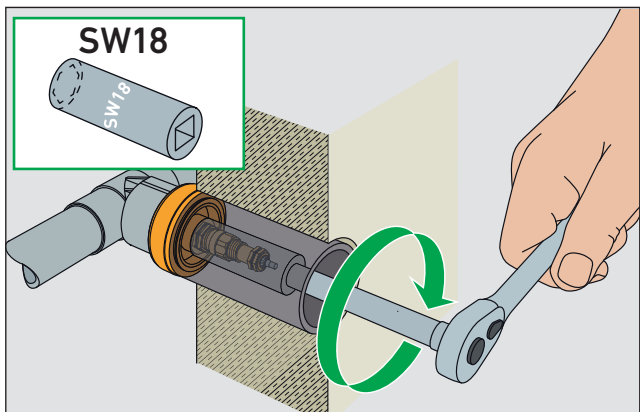

**7**

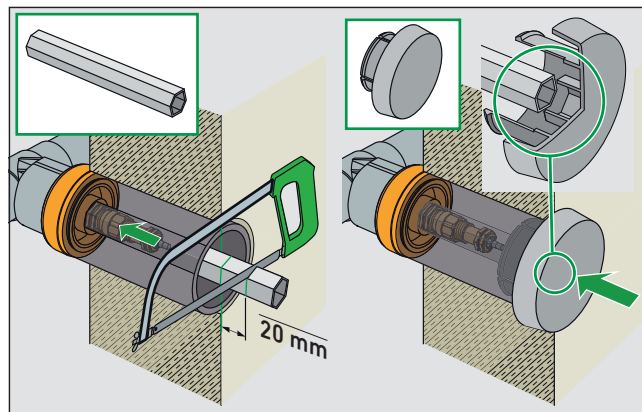

**8**

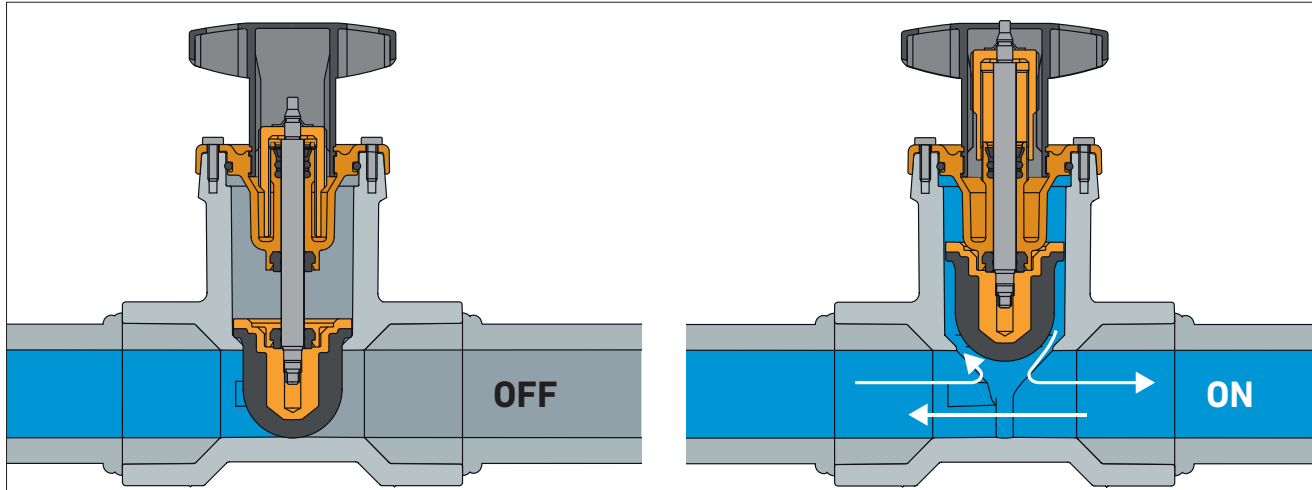

Value z (Zeta)					
ø 20	ø 25	ø 32	ø 40	ø 50	ø 63
0.4	0.4	0.4	0.3	0.3	0.3

Value Kv 100 (m <sup>3</sup> /h)					
ø 20	ø 25	ø 32	ø 40	ø 50	ø 63
25.3	25.3	25.3	77.5	77.5	77.5

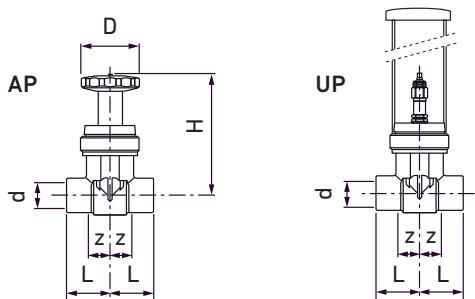

AP	UP	d (mm)	H (mm)	L (mm)	z (mm)	D (mm)
		20	112	40	25	55
		25	112	40	22	55
		32	112	43	23	55
		40	165	55	33	90
		50	165	60	35	90
		63	165	75	47	90

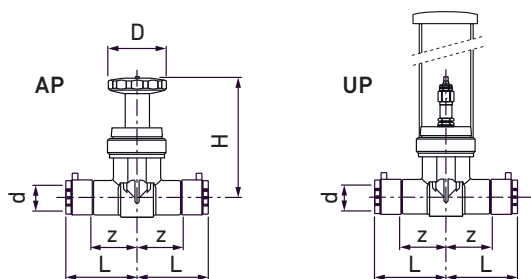

AP	UP	d (mm)	H (mm)	L (mm)	z (mm)	D (mm)
		20	112	86	47	55
		25	112	89	47	55
		32	112	94	52	55
		40	165	112	65	90
		50	165	120	71	90
		63	165	141	90	90

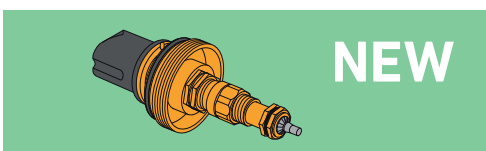

## UP ø 20 / 25 / 32

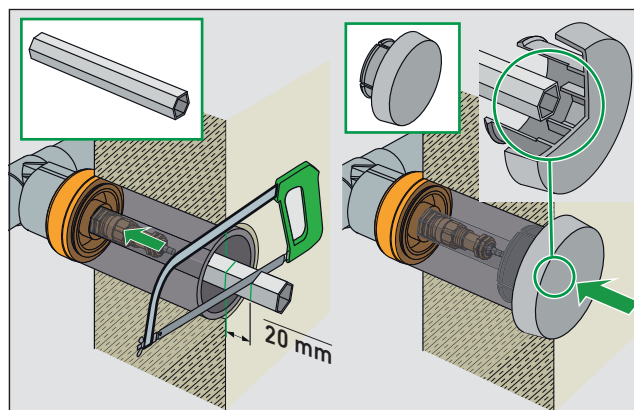
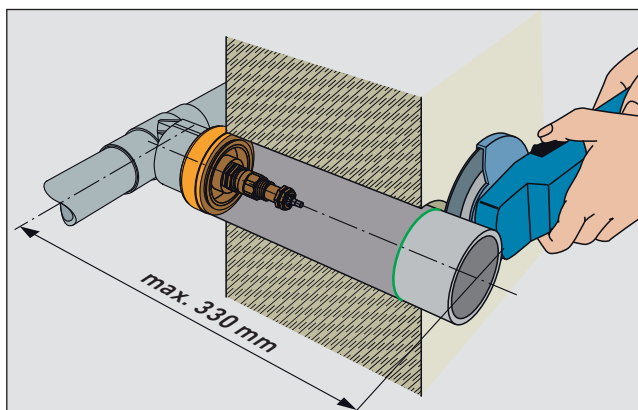

1

2

# PB-valves

## Valve BTV 2 HWS



Electro fusion quality for portable water  
 Gasket: EPDM, approved for potable hot and cold water  
 Brass: UBA conform

d (mm)	DN (mm)	Code	SP	Weight (kg)	D (mm)	L (mm)	H (mm)	z (mm)
20	15	<b>761 069 647</b>	1	0.425	55	86	112	47
25	20	<b>761 069 648</b>	1	0.427	55	89	112	47
32	25	<b>761 069 649</b>	1	0.470	55	94	112	52
40	32	<b>761 069 650</b>	1	1.237	90	112	165	65
50	40	<b>761 069 651</b>	1	1.369	90	120	165	71
63	50	<b>761 069 652</b>	1	1.851	90	141	165	90

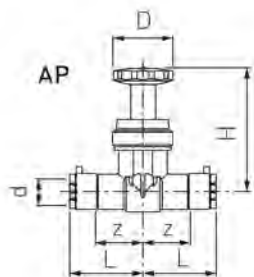

## Valve BTV 2 HWS - spigot G1/4"



Electro fusion quality for portable water  
 Gasket: EPDM, approved for potable hot and cold water  
 Brass: UBA conform

d (mm)	DN (mm)	Code	SP	Weight (kg)	H (mm)	L (mm)	z (mm)	D (mm)
20	15	<b>761 069 653</b>	1	0.489	112	86	47	55
25	20	<b>761 069 654</b>	1	0.494	112	89	47	55
32	25	<b>761 069 655</b>	1	0.520	112	94	52	55
40	32	<b>761 069 656</b>	1	1.298	165	112	65	90
50	40	<b>761 069 657</b>	1	1.431	165	120	71	90
63	50	<b>761 069 658</b>	1	1.754	165	141	90	90

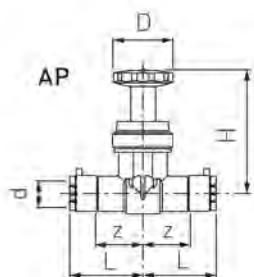



### UPV BTV 2 HWS



Electro fusion quality for portable water  
 Gasket: EPDM, approved for potable hot and cold water  
 Brass: UBA conform

d (mm)	DN (mm)	Code	SP	Weight (kg)	H (mm)	L (mm)	z (mm)	D (mm)
20	15	<b>761 069 659</b>	1	0.607	330	86	47	55
25	20	<b>761 069 660</b>	1	0.609	330	89	47	55
32	25	<b>761 069 661</b>	1	0.652	330	94	52	55

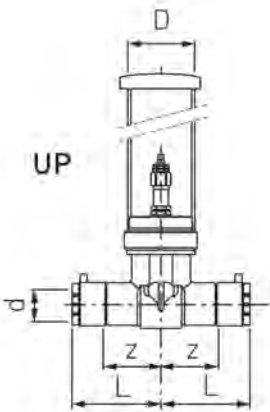

### Valve BTV 2 HMS - without drain



Socket fusion  
 Gasket: EPDM, quality for potable water  
 Brass: UBA conform

d (mm)	Code	SP	Weight (kg)	D (mm)	L (mm)	H (mm)	z (mm)	Value (Zeta)	kv-100-value ( $\Delta p=1$ bar) (L/min)
20	<b>761 070 304</b>	1	0.379	55	40	112	25	0.4	421
25	<b>761 070 305</b>	1	0.370	55	40	112	22	0.4	421
32	<b>761 070 306</b>	1	0.387	55	43	112	23	0.4	421
40	<b>761 070 307</b>	1	1.099	90	55	165	33	0.3	1291
50	<b>761 070 308</b>	1	1.151	90	60	165	35	0.3	1291
63	<b>761 070 309</b>	1	1.492	90	75	165	47	0.3	1291

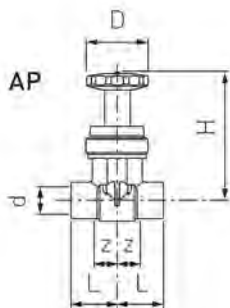

### Valve BTV 2 HMS - with spigot G 1/4"



Socket fusion  
Gasket: EPDM, quality for potable water  
Brass: UBA conform

d (mm)	Code	SP	Weight (kg)	D (mm)	L (mm)	H (mm)	z (mm)	Value (Zeta)	kv-100-value ( $\Delta p=1$ bar) (L/min)
20	<b>761 070 310</b>	1	0.443	55	40	112	25	0.4	421
25	<b>761 070 311</b>	1	0.434	55	40	112	22	0.4	421
32	<b>761 070 312</b>	1	0.434	55	43	112	23	0.4	421
40	<b>761 070 313</b>	1	1.161	90	55	165	33	0.3	1291
50	<b>761 070 314</b>	1	1.213	90	60	165	35	0.3	1291
63	<b>761 070 315</b>	1	1.394	90	75	165	47	0.3	1291

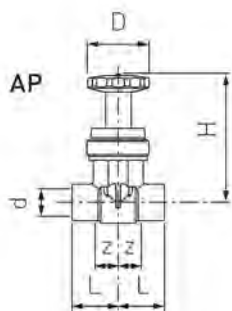

### UPV BTV 2 HMS



Socket fusion  
Gasket: EPDM, quality for potable water  
Brass: UBA conform

d (mm)	DN (mm)	Code	SP	Weight (kg)	D (mm)	L (mm)	H (mm)	z (mm)
20	15	<b>761 070 316</b>	1	0.561	55	40	370	25
25	20	<b>761 070 317</b>	1	0.552	55	40	370	22
32	25	<b>761 070 318</b>	1	0.569	55	43	370	23

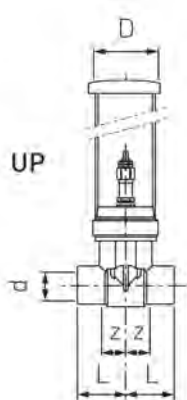

## Spare parts - Retrofit top



### Retrofit top d20/d25

Suitable to repair the old version of the INSTAFLEX system valve and the new BTV 2  
For additional information please see the installation manual for BTV 2 (760 809 086)

d (mm)	Code	Weight (kg)	SP
20 / 25	<b>761 066 896</b>	0.225	1



### Retrofit top d32

Suitable to repair the old version of the INSTAFLEX system valve and the new BTV 2  
For additional information please see the installation manual for BTV 2 (760 809 086)

d (mm)	Code	Weight (kg)	SP
32	<b>761 066 897</b>	0.227	1



### Retrofit top d40/d50/d63

Suitable to repair the old version of the INSTAFLEX system valve and the new BTV 2  
For additional information please see the installation manual for BTV 2 (760 809 086)

d (mm)	Code	Weight (kg)	SP
40 / 50 / 63	<b>761 065 303</b>	0.878	1



### Retrofit top UPV d20/d25

Suitable to repair the old version of the INSTAFLEX system valve and the new BTV 2  
For additional information please see the installation manual for BTV 2 (760 809 086)

d (mm)	Code	Weight (kg)	SP
20 / 25	<b>761 066 898</b>	0.263	1

### Retrofit top UPV d32

Suitable to repair the old version of the INSTAFLEX system valve and the new BTV 2  
For additional information please see the installation manual for BTV 2 (760 809 086)



<b>d</b> (mm)	<b>Code</b>	<b>Weight</b> (kg)	<b>SP</b>
32	<b>761 066 899</b>	0.264	1



### Drain valve and plug

<b>G</b> (inch)	<b>Code</b>	<b>SP</b>	<b>Weight</b> (kg)
1/4	<b>761 066 328</b>	1	0.046

## Ball valves

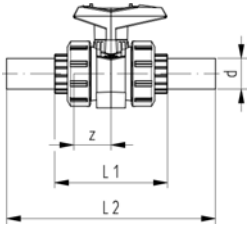

### Ball valve type 546 PVC-C / PB-Spigots

No approval for potable water installations  
Working temperature max. +70°C  
\* on request

	d (mm)	DN (mm)	PN (bar)	EPDM Code	SP	Weight (kg)	L1 (mm)	L2 (mm)	z (mm)
*	20	15	10	761 066 343	1	0.178	95	190	33
*	25	20	10	761 066 344	1	0.271	108	208	38
*	32	25	10	761 066 345	1	0.386	118	218	39
*	40	32	10	761 066 346	1	0.676	137	250	47
*	50	40	10	761 066 347	1	0.988	147	263	49
*	63	50	10	761 066 348	1	1.642	168	288	46

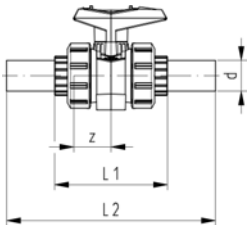

### Ball valve type 546 PP / PB-Spigots

Applicable for compressed air till 10 bar  
No approval for potable water installations  
Working temperature max. +70°C  
\* on request

	d (mm)	DN (mm)	PN (bar)	EPDM Code	SP	Weight (kg)	L1 (mm)	L2 (mm)	z (mm)
*	20	15	10	760 000 343	1	0.141	95	190	33
*	25	20	10	760 000 344	1	0.203	108	208	38
*	32	25	10	760 000 345	1	0.298	118	218	39
*	40	32	10	760 000 346	1	0.512	137	250	47
*	50	40	10	760 000 347	1	0.715	147	263	49
*	63	50	10	760 000 348	1	1.293	168	288	46



### Ball valve type 346 with PB-Flange adapter

Material: PP-H/EPDM

d (mm)	DN (mm)	PN (bar)	EPDM Code	SP	Weight (kg)	D (mm)	L (mm)	L1 (mm)	L2 (mm)	H (mm)	z (mm)	kv-value (Δp=1 bar) (L/min)
20	15	10	760 000 091	1	0.150	46	101	78	62	50	73	185
25	20	10	760 000 092	1	0.250	56	9	92	74	60	87	350
32	25	10	760 000 093	1	0.360	67	130	100	78	70	94	700
40	32	10	760 000 094	1	0.600	82	149	110	88	80	109	1000
50	40	10	760 000 095	1	0.930	98	162	120	94	92	116	1600
63	50	10	760 000 096	1	1.700	121	195	145	113	109	141	3100



DN10/15 - 50

### Ball valve typ 346 with PB-Flange adapter

PVC-C/EPDM

For portable water installations, not DVGW approved

d (mm)	DN (mm)	Inch (inch)	PN (bar)	EPDM Code	SP	Weight (kg)
20	15	1/2	16	<b>761 066 946</b>	1	0.150
25	20	3/4	16	<b>761 066 947</b>	1	0.250
32	25	1	16	<b>761 066 948</b>	1	0.360
40	32	1 1/4	16	<b>761 066 949</b>	0	0.600
50	40	1 1/2	16	<b>761 066 950</b>	1	0.930
63	50	2	16	<b>761 066 951</b>	1	1.700

d (mm)	D (mm)	L (mm)	L1 (mm)	L2 (mm)	H (mm)	z (mm)	kv-value ( $\Delta p=1$ bar) (l/min)
20	45	102	78	63	50	71	185
25	56	120	92	75	60	82	350
32	67	131	100	79	70	87	700
40	82	150	110	89	80	98	1000
50	98	163	120	95	92	101	1600
63	120	197	166	115	110	121	3100

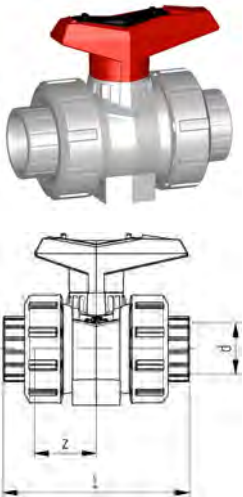

### Ball valve type 546 PVC-C - PB-flange adaptor - socket fusion

For portable water installations, not DVGW approved

d (mm)	DN (mm)	PN (bar)	EPDM Code	SP	Weight (kg)	L (mm)	z (mm)
20	15	16	<b>761 066 337</b>	1	0.160	95	33
25	20	16	<b>761 066 338</b>	1	0.243	108	38
32	25	16	<b>761 066 339</b>	1	0.349	118	39
40	32	16	<b>761 066 340</b>	1	0.614	137	47
50	40	16	<b>761 066 341</b>	1	0.838	147	49
63	50	16	<b>761 066 342</b>	1	1.546	168	46

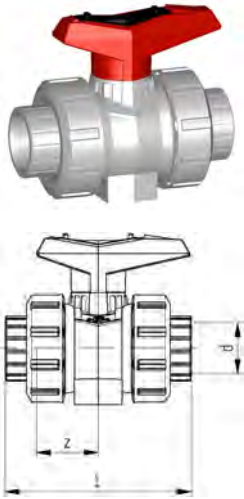

### Ball valve type 546 PP - PB-flange adaptor - socket fusion

For portable water installations, not DVGW approved

d (mm)	DN (mm)	PN (bar)	EPDM Code	SP Weight (kg)	L (mm)	z (mm)	
20	15	16	<b>760 000 337</b>	1	0.119	95	33
25	20	16	<b>760 000 338</b>	1	0.182	108	38
32	25	16	<b>760 000 339</b>	1	0.255	118	39
40	32	16	<b>760 000 340</b>	1	0.446	137	47
50	40	16	<b>760 000 341</b>	1	0.609	147	49
63	50	16	<b>760 000 342</b>	1	1.118	168	46



### PB Flange adaptor flat with spigot

Suitable to ball valve 546  
on request

d (mm)	Code	SP Weight (kg)	D (mm)	D1 (mm)	h (mm)	
20	<b>761 069 627</b>	1	0.008	27	34	66
25	<b>761 069 628</b>	1	0.025	33	41	71
32	<b>761 069 629</b>	1	0.039	41	50	74
40	<b>761 069 630</b>	1	0.027	50	61	82
50	<b>761 069 631</b>	1	0.094	61	73	87
63	<b>761 069 632</b>	1	0.074	76	90	94



# Butterfly valves



## Metal - butterfly valve type 039M With hand lever

### Model:

- Body GGG40 (A 395 M:88, EN-JS 1020 EN1563) Rilsan coating
- Seat material: EPDM, FPM and others on request
- Full bore shaft, square shape
- Installation length: EN 558 row 20
- Mounting between ISO, ANSI, BS or JIS Flanges
- Interface according to DIN/ISO 5211
- Also available: gearbox with handwheel, electric-, pneumatic actuated

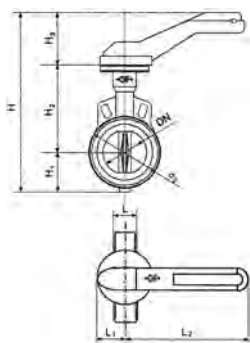

d (mm)	Size (inch)	DN (mm)	PN (bar)	kv-value ( $\Delta p=1$ bar) (l/min)	Disc: ductile iron/Rilsan® coated EPDM Code	SP	Weight (kg)	Disc: stainless steel EPDM Code	SP	Weight (kg)
75	2 1/2	65	16	4667	<b>199 039 001</b>	1	2.100	<b>199 039 201</b>	1	2.100
90	3	80	16	7167	<b>199 039 002</b>	1	2.300	<b>199 039 202</b>	1	2.300
110	4	100	16	11833	<b>199 039 003</b>	1	3.500	<b>199 039 203</b>	1	3.500
140	5	125	16	18333	<b>199 039 004</b>	1	4.300	<b>199 039 204</b>	1	4.300
160	6	150	16	26667	<b>199 039 005</b>	1	5.700	<b>199 039 205</b>	1	5.700
225	8	200	16	46667	<b>199 039 006</b>	1	8.400	<b>199 039 206</b>	1	8.400
280	10	250	16	78333	<b>199 039 007</b>	1	17.000	<b>199 039 207</b>	1	17.000
315	12	300	16	115000	<b>199 039 008</b>	1	35.500	<b>199 039 208</b>	1	21.000

d (mm)	H (mm)	H1 (mm)	H2 (mm)	H3 (mm)	L (mm)	L1 (mm)	L2 (mm)	Cv val- ue ( $\Delta p=1$ psi) (l/min)	d3 (mm)
75	312	63	152	95	46	45	220	1233	114
90	327	71	159	95	46	45	220	1893	131
110	360	87	178	95	52	45	220	3126	152
140	388	102	191	95	56	45	320	4843	182
160	416	118	203	95	56	45	320	7045	209
225	489	149	245	95	60	45	320	12328	262
280	525	200	275	50	68	63	560	20693	331
315	592	227	315	50	78	63	560	30380	380



**Metal - butterfly valve type 039G**  
**Reduction gear with handwheel**

**Model:**

- Body GGG40 (A 395 M:88, EN-JS 1020 EN1563) Rilsan coating
- Seat material: EPDM, FPM and others on request
- Full bore shaft, square shape
- Installation length: EN 558 row 20
- Mounting between ISO, ANSI, BS or JIS Flanges
- Interface according to DIN/ISO 5211

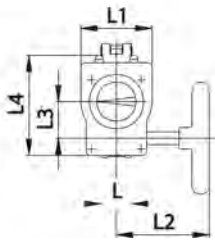
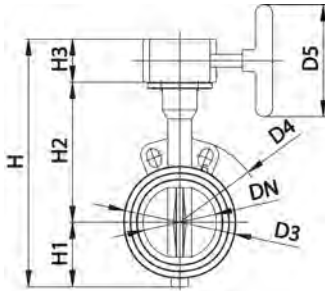

d (mm)	Size (inch)	DN (mm)	PN (bar)	kv-value ( $\Delta p=1$ bar) (l/min)	Disc: ductile iron/Rilsan® coated EPDM Code	SP	Weight (kg)	Disc: stainless steel EPDM Code	SP	Weight (kg)
75	2 1/2	65	16	4667	<b>199 039 027</b>	1	3.600	<b>199 039 227</b>	1	3.600
90	3	80	16	7167	<b>199 039 028</b>	1	3.800	<b>199 039 228</b>	1	3.800
110	4	100	16	11833	<b>199 039 029</b>	1	4.800	<b>199 039 229</b>	1	4.800
140	5	125	16	18333	<b>199 039 030</b>	1	5.600	<b>199 039 230</b>	1	5.600
160	6	150	16	26667	<b>199 039 031</b>	1	7.000	<b>199 039 231</b>	1	7.000
225	8	200	16	46667	<b>199 039 032</b>	1	9.500	<b>199 039 232</b>	1	9.500
280	10	250	16	78333	<b>199 039 033</b>	1	31.600	<b>199 039 233</b>	1	19.000
315	12	300	16	115000	<b>199 039 034</b>	1	40.000	<b>199 039 234</b>	1	37.000

d (mm)	D3 (mm)	D4 (mm)	D5 (mm)	H (mm)	H1 (mm)	H2 (mm)	H3 (mm)	L1 (mm)	L2 (mm)	L3 (mm)	L4 (mm)	Cv val- ue ( $\Delta p=1$ psi) (l/min)
75	114	185	125	275	65	152	58	84	152	38	107	1233
90	131	190	125	290	73	159	58	84	152	38	107	1893
110	152	229	125	323	87	178	58	84	152	38	107	3126
140	182	254	125	351	102	191	58	84	152	38	107	4843
160	209	285	125	379	118	203	58	84	152	38	107	7045
225	262	343	125	452	149	245	58	84	152	38	107	12328
280	331	333	250	542	200	275	67	106	184	52	142	20693
315	380	353	250	609	227	315	67	106	184	52	142	30380

## Additional components



### PROGEF Standard Pressure reducing valve type 582 Unions with butt fusion spigots SDR11 metric Without manometer

#### Model:

- Diaphragm PTFE/EPDM
- Integrated stainless steel mounting inserts
- 0.5-9.0 bar (7-130 psi)

0.3-3.0 bar (4-44 psi) on request

Manometer on request

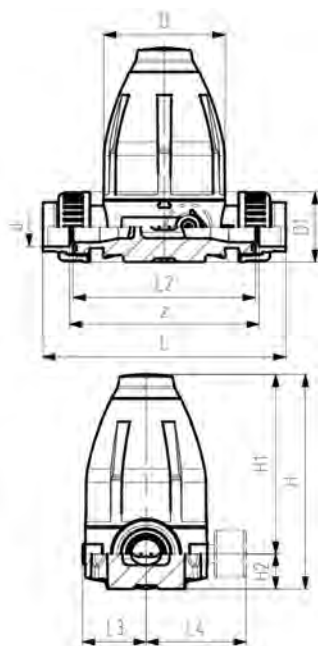

d (mm)	DN (mm)	PN (bar)	O-rings EPDM Code	Weight (kg)	SP	O-rings FPM Code	SP
20	15	10	<b>167 582 502</b>	0.640	1	<b>167 582 512</b>	1
25	20	10	<b>167 582 503</b>	1.350	1	<b>167 582 513</b>	1
32	25	10	<b>167 582 504</b>	1.370	1	<b>167 582 514</b>	1
40	32	10	<b>167 582 505</b>	3.660	1	<b>167 582 515</b>	1
50	40	10	<b>167 582 506</b>	3.710	1	<b>167 582 516</b>	1
63	50	10	<b>167 582 507</b>	3.860	1	<b>167 582 517</b>	1

d (mm)	D (mm)	D1 (mm)	H (mm)	H1 (mm)	H2 (mm)	H3 (mm)	L (mm)	L2 (mm)	L3 (mm)	L5 (mm)	M	z (mm)	closest inch (inch)
20	79	48	132	111	21	12	158	120	42	40	M6	126	½
25	100	58	177	148	29	14	192	150	53	46	M6	156	¾
32	100	65	177	148	29	14	196	150	53	46	M6	156	1
40	147	77	251	207	44	21	255	205	76	65	M8	211	1 ¼
50	147	84	251	207	44	21	261	205	76	65	M8	211	1 ½
63	147	111	251	207	44	21	269	205	76	65	M8	211	2



### PB socket fusion adapter for standard union

Insert for socket fusion fittings with a pre-assembled messing ring for an optimal force distribution

Suitable for all common metric plastic unions

\* on request

	d (mm)	DN (mm)	Code
*	20	15	<b>761 066 031</b>
*	25	20	<b>761 066 032</b>
*	32	25	<b>761 066 033</b>
*	40	32	<b>761 066 034</b>
*	50	40	<b>761 066 035</b>
*	63	50	<b>761 066 036</b>

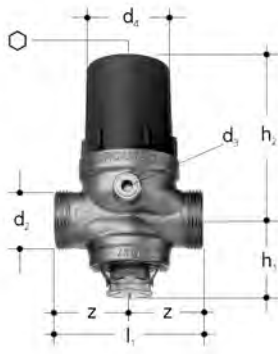

### JRGURED pressure reducing valve without unions, PN 25 - 4 bar

Made of gunmetal, cover made of glass fibre reinforced plastic, slider and valve seat made of stainless steel, membrane and valve seal made of EPDM, manometer connection on both sides, sealed with 5149 plugs, stainless steel 1000 µm, transparent filter cup made of plastic. Without unions. Factory setting 400 kPa (4 bar).

EPDM gaskets cannot be oiled neither be greased. EPDM membranes and gaskets are not suitable for oleaginous compressed air.

Secondary pressure 200-600 kPa (2-6 bar), Tmax 30°C

GN (inch)	DN (mm)	JRG Code	GF Code	SP	Weight (kg)
½	15	<b>1303.015</b>	<b>350 712 301</b>	1	0.620
¾	20	<b>1303.020</b>	<b>350 712 401</b>	1	0.770
1	25	<b>1303.025</b>	<b>350 712 501</b>	1	1.340
1 ¼	32	<b>1303.032</b>	<b>350 712 601</b>	1	1.800
1 ½	40	<b>1303.040</b>	<b>350 712 701</b>	1	3.400
2	50	<b>1303.050</b>	<b>350 712 801</b>	1	4.900
2 ½	65	<b>1303.065</b>	<b>350 734 701</b>	1	5.200

GN (inch)	DN (mm)	d2 G (inch)	d3 Rp (inch)	d4 (mm)	h1 (mm)	h2 (mm)	l1 (mm)	z (mm)	⊕
½	15	¾	⅙	54	34	79	80	40	5
¾	20	1	⅙	60	42	86	85	43	5
1	25	1 ¼	¼	72	52	110	100	50	6
1 ¼	32	1 ½	¼	80	64	121	120	60	6
1 ½	40	1 ¾	¼	96	80	157	145	73	8
2	50	2 ¾	¼	105	98	172	175	88	8
2 ½	65	3	¼	105	98	172	180	90	8



### Return flow inhibitor, BR1, PN 16

Outlets with BR 1 external thread according to EN ISO 228-1, without screw connection, threaded connection for test and drain valve, closed with closure plug 5149, without test and drain valve.

Made of gunmetal, stainless steel valve seat and closing spring, plastic return flow inhibitor, PPSU baffle, EPDM seals. For water up to 90°C, opening pressure less than 5 kPa (50 mbar). Tested according DIN EN 1213, noise tested, valve sound group 1. Check valve replacement see 1628, test and drain valve see 7301.080. Unions to plastic systems: 4700, 5550. Unions to stainless steel systems: 8350, 8355. Unions to threaded connections: 8201, 8205, 8299, 8333, 8339, 8360. It's required to use only AFM 34 gaskets. These cannot be oiled neither be greased.

DN (mm)	JRG Code	GF Code	SP	Weight (kg)
15	<b>1611.015</b>	<b>350 896 244</b>	1	0.311
20	<b>1611.020</b>	<b>350 896 245</b>	1	0.460
25	<b>1611.025</b>	<b>350 896 246</b>	1	0.749
32	<b>1611.032</b>	<b>350 896 247</b>	1	0.860
40	<b>1611.040</b>	<b>350 896 248</b>	1	1.257
50	<b>1611.050</b>	<b>350 896 249</b>	1	1.860

DN (mm)	d1 G (inch)	d2 G (inch)	d3 Rp (inch)	h (mm)	l (mm)	l3 (mm)	l4 (mm)	l5 (mm)	⊕
15	¾	½	¼	42	75	24	52	6	6
20	1	¾	¼	51	87	24	63	7	6
25	1 ¼	1	¼	61	99	24	75	8	6
32	1 ½	1 ¼	¼	80	118	30	89	9	6
40	1 ¾	1 ½	¼	91	130	31	100	10	6
50	2 ¾	2	¼	107	155	35	120	11	6



### Return flow inhibitor, BR1, PN 16

Outlets with BR 1 external thread according to EN ISO 228-1, without screw connection, threaded connection for test and drain valve, closed with closure plug 5149, without test and drain valve. Made of gunmetal, stainless steel valve seat and closing spring, plastic return flow inhibitor, PPSU baffle, EPDM seals.

For water up to 90°C, opening pressure less than 5 kPa (50 mbar).

Tested according DIN EN 1213.

Check valve replacement see 1628, test and drain valve see 7301.080.

Unions to plastic systems: 4700, 5550.

Unions to stainless steel systems: 8350, 8355.

Unions to threaded connections: 8201, 8205, 8299, 8333, 8339, 8360.

It's required to use only AFM 34 gaskets.

These cannot be oiled neither be greased.

DN (mm)	JRG Code	GF Code	SP	Weight (kg)
65	<b>1611.065</b>	<b>350 898 302</b>	1	3.120

DN (mm)	d1 G (inch)	d2 G (inch)	d3 Rp (inch)	h (mm)	l1 (mm)	l3 (mm)	l4 (mm)	l5 (mm)	6
65	3	2 ½	¼	116	190	43	147	14.5	6



### Safety valve JRGARANT, reaction pressure 6 bar

For closed model water heater, inlet with male thread, outlet with female thread.

Body made of gunmetal, upper part made of plastic, factory setting of operating pressure for the safety valve.

Upper part to 1025 see 1045, water dropping nipple to 1025 see 8223.

GN (inch)	DN (mm)	JRG Code	GF Code	SP	Weight (kg)
½	15	<b>1025.240</b>	<b>350 599 405</b>	1	0.242
¾	20	<b>1025.320</b>	<b>350 599 505</b>	1	0.285
1	25	<b>1025.400</b>	<b>350 599 606</b>	1	0.556

GN (inch)	DN (mm)	d1 R (inch)	d2 Rp (inch)	h1 (mm)	h2 (mm)	l1 (mm)	l2 (mm)	PN (bar)	Temperature (°C)	z (mm)
½	15	½	½	28	60	38	47	10	90	15
¾	20	¾	¾	32	62	41	48	10	90	17
1	25	1	1	39	82	46	65	10	90	22



### Slanted filter, PN 16

made of gunmetal, female thread on both sides, extensive filter element made of rust-free steel mesh, for water, air, oil etc. up to 100°C.

GN (inch)	DN (mm)	JRG Code	GF Code	SP	Weight (kg)	d1 Rp (inch)	d2 G (inch)	h1 (mm)	l (mm)	z1 (mm)	z2 (mm)	μm
¾	10	<b>1810.160</b>	<b>350 872 101</b>	1	0.170	¾	½	40	60	10	30	560
½	15	<b>1810.240</b>	<b>350 870 901</b>	1	0.250	½	½	45	65	10	27	560
¾	20	<b>1810.320</b>	<b>350 871 001</b>	1	0.350	¾	¾	53	75	12	33	560
1	25	<b>1810.400</b>	<b>350 871 101</b>	1	0.574	1	1	64	90	15	40	560
1 ¼	32	<b>1810.480</b>	<b>350 871 201</b>	1	0.870	1 ¼	1 ¼	77	110	19	52	800
1 ½	40	<b>1810.560</b>	<b>350 871 301</b>	1	1.290	1 ½	1 ½	89	120	20	61	800
2	50	<b>1810.640</b>	<b>350 871 401</b>	1	1.950	2	2	111	150	23	77	800
2 ½	65	<b>1810.720</b>	<b>350 871 501</b>	1	3.480	2 ½	2 ½	122	180	22	98	800
3	80	<b>1810.800</b>	<b>350 871 601</b>	1	5.420	3	3	136	210	27	117	800



### Fine filter, PN 16

With female thread, PN16.

Threaded connection for aeration and ventilation and manometer valve closed with plug. Gunmetal body, transparent plastic filter cup with drain cock, fine filter element 100 µm, threaded ring and key, for water up to max. 30°C.

Plug see 5149.080, filter cup 1848 / 1849, filter element 1838 / 1839, fine filter key 8127.000  
Transparent filter cups have to be protected from UV rays and aggressive surroundings/ influences.

The filter element has to be replaced periodically min. twice a year.  
Installation in horizontal pipe lines only.

GN (inch)	DN (mm)	JRG Code	GF Code	SP	Weight (kg)	d1 Rp (inch)	d2 (mm)	h1 (mm)	h3 (mm)	l (mm)	z (mm)	µm
1	25	1830.400	350 690 001	1	3.000	1	122	370	430	130	48	100
1 ¼	32	1830.480	350 690 002	1	3.150	1 ¼	122	372	432	150	56	100
1 ½	40	1830.560	350 690 003	1	3.200	1 ½	122	374	434	150	56	100
2	50	1830.640	350 690 004	1	3.450	2	122	380	440	160	56	100

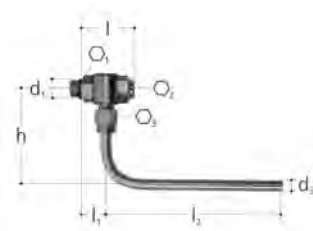

### Sampling valve

With male thread, PN 16

For microbiological water analysis with temperature indicator (7306.090) incl. operating key for hot water up to max. 90°C, Gunmetal body, metallical sealing, water pocket free design, EPDM gaskets, Sampling pipe made of stainless steel, extraction position adjustable 360°, suitable to: JRG LegioStop products 1610-1631, 2190/2191 return flow inhibitor, 3600-3609 JRG LegioTherm 2T, 5200-5234 Y-type valves, 5262-5284 combined return flow inhibitor, 5354/5371 straight seat valve.

GN (inch)	DN (mm)	JRG Code	GF Code	SP	Weight (kg)
¼	8	7306.080	351 110 365	1	0.190
¾	8	7306.160	351 110 500	1	0.190

GN (inch)	DN (mm)	d1 R (inch)	d3 (mm)	h (mm)	l (mm)	l1 (mm)	l2 (mm)	Ø1	Ø2	Ø3
¼	8	¼	8	65	35	16	125	20	5	14
¾	8	¾	8	65	35	16	125	20	5	14

# System adapters

**Male thread**  
**Female thread**  
**Loose nut**  
**Adapter union**





### Adapter - male thread

Socket fusion transition to male thread  
Thread in DZR brass, UBA (Umwelt Bundesamt, Germany) conform  
EPDM sealing hot and cold water approved

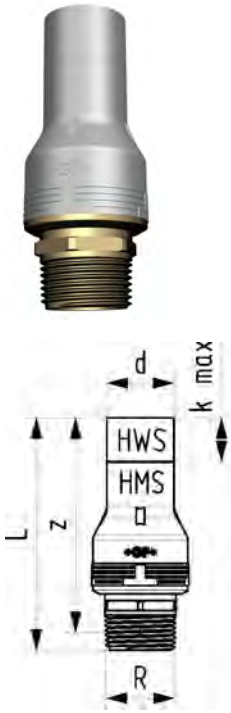

d (mm)	R (inch)	Code	SP	Weight (kg)	L (mm)	z (mm)	k max. (mm)
16	½	<b>761 069 666</b>	1	0.082	96	83	22
20	½	<b>761 069 667</b>	1	0.098	99	86	24
20	¾	<b>761 069 668</b>	1	0.118	101	86	24
25	¾	<b>761 069 669</b>	1	0.129	104	89	23
25	1	<b>761 069 670</b>	1	0.160	107	90	23
32	1	<b>761 069 671</b>	1	0.206	111	94	21
40	1 ¼	<b>761 069 672</b>	1	0.402	133	114	24
50	1 ½	<b>761 069 673</b>	1	0.505	138	119	22
63	2	<b>761 069 674</b>	1	0.868	156	132	21

### Adapter - female thread

Socket fusion transition to female thread  
Thread in DZR brass, UBA (Umwelt Bundesamt, Germany) conform  
EPDM sealing hot and cold water approved

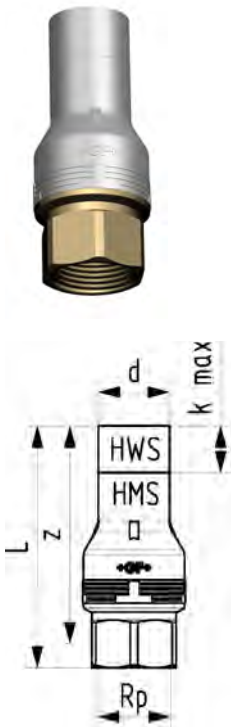

d (mm)	Rp (inch)	Code	SP	Weight (kg)	L (mm)	z (mm)	k max. (mm)
16	½	<b>761 069 675</b>	1	0.091	97	84	22
20	½	<b>761 069 676</b>	1	0.104	100	87	23
20	¾	<b>761 069 677</b>	1	0.133	100	85	23
25	¾	<b>761 069 678</b>	1	0.152	104	89	23
25	1	<b>761 069 679</b>	1	0.190	108	91	23
32	1	<b>761 069 680</b>	1	0.227	109	92	21
40	1 ¼	<b>761 069 681</b>	1	0.424	130	111	24
50	1 ½	<b>761 069 682</b>	1	0.598	135	116	22
63	2	<b>761 069 683</b>	1	0.908	148	124	21

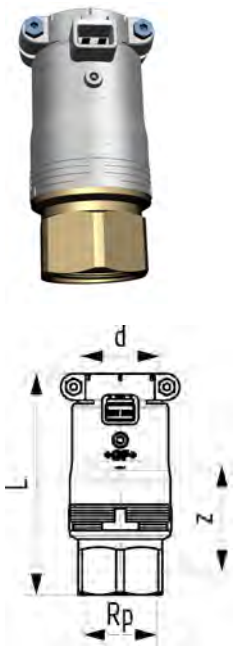

### Adapter - female thread

Electro fusion transition to female thread  
Thread in DZR brass, UBA (Umwelt Bundesamt, Germany) conform  
EPDM sealing hot and cold water approved

d (mm)	Rp (inch)	Code	SP	Weight (kg)	L (mm)	z (mm)
16	½	<b>761 069 702</b>	1	0.164	88	35
20	½	<b>761 069 703</b>	1	0.173	91	37
20	¾	<b>761 069 704</b>	1	0.144	91	35
25	¾	<b>761 069 705</b>	1	0.167	95	37
25	1	<b>761 069 706</b>	1	0.205	100	39
32	1	<b>761 069 707</b>	1	0.246	100	39
40	1 ¼	<b>761 069 708</b>	1	0.439	119	51
50	1 ½	<b>761 069 709</b>	1	0.625	124	56
63	2	<b>761 069 710</b>	1	0.924	142	65

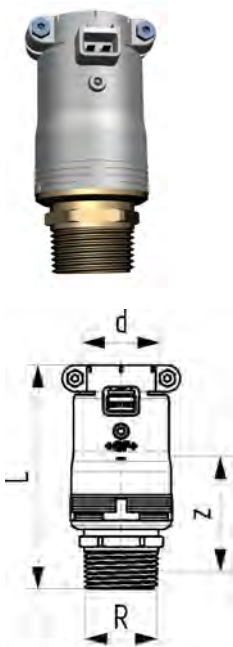

### Adapter - male thread

Electro fusion transition to male thread  
Thread in DZR brass, UBA (Umwelt Bundesamt, Germany) conform  
EPDM sealing hot and cold water approved

d (mm)	R (inch)	Code	SP	Weight (kg)	L (mm)	z (mm)
16	½	<b>761 069 711</b>	1	0.093	87	36
20	½	<b>761 069 712</b>	1	0.113	90	37
20	¾	<b>761 069 713</b>	1	0.131	92	38
25	¾	<b>761 069 714</b>	1	0.148	96	39
25	1	<b>761 069 715</b>	1	0.175	98	39
32	1	<b>761 069 716</b>	1	0.232	102	43
40	1 ¼	<b>761 069 717</b>	1	0.430	122	56
50	1 ½	<b>761 069 718</b>	1	0.545	127	61
63	2	<b>761 069 719</b>	1	0.935	150	76

### Adapter loose union nut - flat seal

Socket fusion transition to loose nut adapter concentering  
 Thread in DZR brass, UBA (Umwelt Bundesamt, Germany) conform  
 EPDM sealing hot and cold water approved  
 Incl. flat seal EPDM  
 \* only for the UK market  
 \* with centering

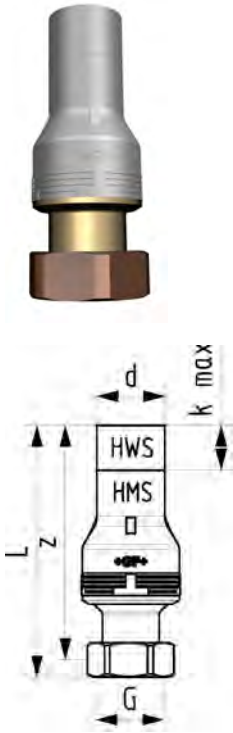

d (mm)	G (inch)	Code	SP	Weight (kg)	L (mm)	z (mm)	k max. (mm)	L min. (mm)	SF (mm)
16	¾	761 069 684	1	0.715	100	93	22	17	
20	¾	761 069 685	1	0.230	102	94	24	16	
20	1	761 069 686	1	0.186	107	98	24	16	
25	¾	761 069 687	1	0.190	108	101	23	20	
25	1	761 069 688	1	0.200	110	102	23	20	
25	1 ¼	761 069 689	1	0.274	118	109	23	20	
32	1	761 069 690	1	0.229	118	110	21	22	
32	1 ¼	761 069 691	1	0.292	118	110	21	22	
32	1 ½	761 069 692	1	0.380	119	110	21	22	
40	1 ¼	761 069 693	1	0.386	134	105	24	26	
40	1 ½	761 069 694	1	0.458	132	124	24	24	
40	2	761 069 695	1	0.595	139	126	24	24	
50	1 ¾	761 069 696	1	0.599	142	131	22	28	
50	2 ¼	761 069 697	1	0.782	150	138	22	28	
63	2 ¾	761 069 698	1	1.139	159	147	21	30	
63	2 ¾	761 069 699	1	1.210	161	146	21	30	
*	16	½	761 069 700	1	0.093	98	91	22	16
*	20	¾	761 069 701	1	0.149	102	95	24	16

### Adapter loose union nut - flat seal

Electro fusion transition to loose nut adapter  
 Thread in DZR brass, UBA (Umwelt Bundesamt, Germany) conform  
 EPDM sealing hot and cold water approved  
 Incl. flat seal EPDM  
 \* only for the UK market  
 \* with centering

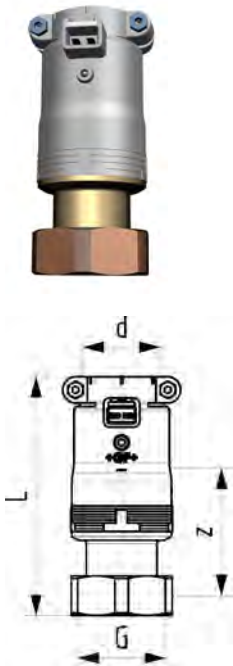

d (mm)	G (inch)	Code	SP	Weight (kg)	L (mm)	z (mm)	
16	¾	761 069 720	1	0.143	90	46	
20	¾	761 069 721	1	0.132	92	46	
20	1	761 069 722	1	0.167	98	50	
25	¾	761 069 723	1	0.196	99	50	
25	1	761 069 724	1	0.202	102	51	
25	1 ¼	761 069 725	1	0.290	109	58	
32	1	761 069 726	1	0.261	109	58	
32	1 ¼	761 069 727	1	0.315	109	58	
32	1 ½	761 069 728	1	0.374	110	58	
40	1 ¼	761 069 729	1	0.420	123	67	
40	1 ½	761 069 730	1	0.490	121	64	
40	2	761 069 731	1	0.614	128	68	
50	1 ¾	761 069 732	1	0.666	131	73	
50	2 ¼	761 069 733	1	0.826	138	77	
63	2 ¾	761 069 734	1	1.186	152	89	
63	2 ¾	761 069 735	1	1.246	155	89	
*	16	½	761 069 736	1	0.166	88	44
*	20	¾	761 069 737	1	0.134	93	47



### Adaptor union

Spigot for electro fusion and socket fusion - male thread  
Including EPDM O-Ring, quality suitable for potable water

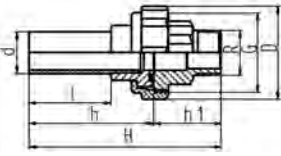

d (mm)	R (inch)	Code	SP	Weight (kg)	D (mm)	H (mm)	G (inch)	h (mm)	h1 (mm)	l (mm)
16	½	761 069 400	1	0.221	41	106	1	68	38	45
20	½	761 069 401	1	0.232	46	110	1 ¼	70	40	47
25	¾	761 069 402	1	0.340	52	117	1 ½	76	41	50
32	1	761 069 403	1	0.489	64	123	2	78	45	50
40	1 ¼	761 069 404	1	0.673	79	136	2 ½	88	48	56
50	1 ½	761 069 405	1	0.783	85	141	2 ¾	93	48	58
63	2	761 069 406	1	1.100	104	152	3 ½	98	54	60



### Adaptor union

Spigot for electro fusion and socket fusion - female thread  
Including EPDM O-Ring, quality suitable for potable water

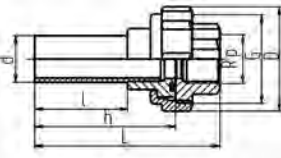

d (mm)	Rp (inch)	Code	SP	Weight (kg)	D (mm)	L (mm)	G (inch)	l (mm)	h (mm)	z (mm)
16	½	761 069 407	1	0.171	41	90	1	45	68	9
20	½	761 069 408	1	0.225	46	94	1 ¼	47	70	10
25	¾	761 069 409	1	0.274	52	100	1 ½	50	76	9
32	1	761 069 410	1	0.391	64	103	2	50	78	8
40	1 ¼	761 069 411	1	0.620	79	114	2 ½	56	88	7
50	1 ½	761 069 412	1	0.678	85	119	2 ¾	58	93	7
63	2	761 069 413	1	1.036	104	126	3 ½	60	98	5



### Union, socket-socket

Including EPDM O-Ring, quality suitable for potable water

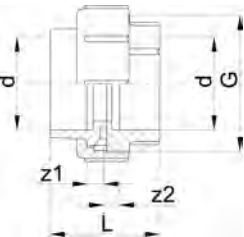

d (mm)	Code	SP	Weight (kg)	G (inch)	L (mm)	z1 (mm)	z2 (mm)
16	761 066 691	10	0.135	1	43	8	5
20	761 066 692	10	0.164	1 ¼	43	8	5
25	761 066 693	10	0.208	1 ½	49	8	5
32	761 066 694	5	0.300	2	53	8	5
40	761 066 695	5	0.469	2 ½	59	10	5
50	761 066 696	2	0.525	2 ¾	65	10	5
63	761 066 697	2	0.766	3 ½	71	10	5

### Adaptor union - socket-male thread

Including EPDM O-Ring, quality suitable for potable water

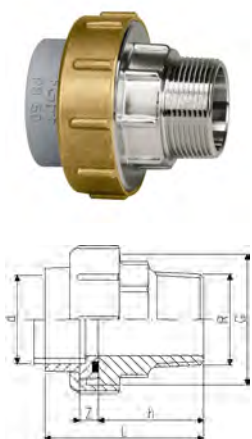

d (mm)	R (inch)	Code	SP	Weight (kg)	G (inch)	L (mm)	h (mm)	z (mm)
16	½	<b>761 066 698</b>	10	0.215	1	61	38	8
20	½	<b>761 066 699</b>	10	0.217	1 ¼	63	40	8
25	¾	<b>761 066 700</b>	10	0.324	1 ½	67	41	8
32	1	<b>761 066 701</b>	5	0.474	2	73	45	8
40	1 ¼	<b>761 066 702</b>	5	0.634	2 ½	80	48	10
50	1 ½	<b>761 066 703</b>	2	0.719	2 ¾	83	48	10
63	2	<b>761 066 704</b>	2	1.006	3 ½	92	54	10

### Adaptor union - socket-female thread

Including EPDM O-Ring, quality suitable for potable water

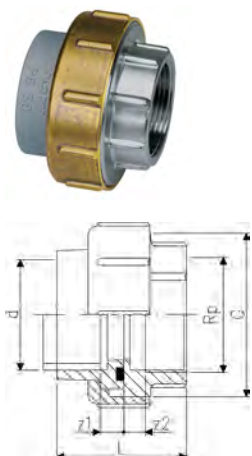

d (mm)	Rp (inch)	Code	SP	Weight (kg)	L (mm)	z1 (mm)	z2 (mm)	G (inch)
16	½	<b>761 066 705</b>	10	0.164	45	8	9	1
20	½	<b>761 066 706</b>	10	0.219	47	8	10	1 1/4
25	¾	<b>761 066 707</b>	10	0.268	50	8	9	1 1/2
32	1	<b>761 066 708</b>	5	0.270	53	8	8	2
40	1 ¼	<b>761 066 709</b>	5	0.600	58	10	7	2 1/2
50	1 ½	<b>761 066 710</b>	2	0.700	61	10	7	2 3/4
63	2	<b>761 066 711</b>	2	0.950	66	10	5	3 1/2

### Electrofusion adaptor union

Including EPDM O-Ring, quality suitable for potable water

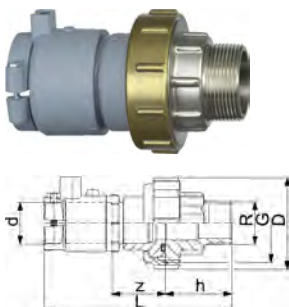

d (mm)	R (inch)	Code	SP	Weight (kg)	D (mm)	L (mm)	G (inch)	h (mm)	z (mm)
16	½	<b>761 069 475</b>	1	0.236	41	106	1	38	31
20	½	<b>761 069 476</b>	1	0.248	50	109	1 ¼	40	30
25	¾	<b>761 069 477</b>	1	0.331	56	116	1 ½	41	33
32	1	<b>761 069 478</b>	1	0.476	69	124	2	45	37
40	1 ¼	<b>761 069 479</b>	1	0.728	83	137	2 ½	48	42
50	1 ½	<b>761 069 480</b>	1	0.842	90	143	2 ¾	48	46
63	2	<b>761 069 481</b>	1	1.196	110	158	3 ½	54	53

### Electrofusion adaptor union

Including EPDM O-Ring, quality suitable for potable water

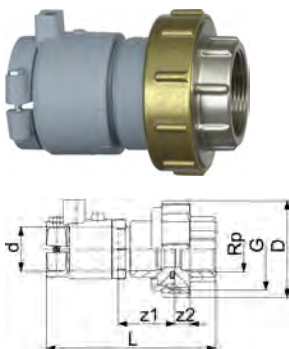

d (mm)	Rp (inch)	Code	SP	Weight (kg)	D (mm)	L (mm)	G (inch)	z1 (mm)	z2 (mm)
16	½	<b>761 069 482</b>	1	0.185	41	90	1	31	9
20	½	<b>761 069 483</b>	1	0.250	50	93	1 ¼	30	10
25	¾	<b>761 069 484</b>	1	0.298	56	99	1 ½	33	9
32	1	<b>761 069 485</b>	1	0.425	69	104	2	37	8
40	1 ¼	<b>761 069 486</b>	1	0.686	83	115	2 ½	42	7
50	1 ½	<b>761 069 487</b>	1	0.738	90	121	2 ¾	46	7
63	2	<b>761 069 488</b>	1	1.133	110	132	3 ½	53	5



### Female threaded HWS screw connection for valves

With EPDM O-ring seals Comes  
With Klingerit gasket

d (mm)	G1 (inch)	Code	SP	Weight (kg)	D (mm)	L (mm)	z1 (mm)	z2 (mm)	G (inch)
20	¾	<b>761 069 641</b>	1	0.245	50	89	30	10	1 ¼
25	1	<b>761 069 642</b>	1	0.316	56	95	33	10	1 ½
32	1 ¼	<b>761 069 643</b>	1	0.427	69	98	37	10	2
40	1 ½	<b>761 069 644</b>	1	0.705	83	112	42	11	2 ½
50	1 ¾	<b>761 069 645</b>	1	0.835	90	118	46	11	2 ¾
63	2 ¾	<b>761 069 646</b>	1	1.233	110	127	53	11	3 ½



### Adaptor INSTAFLEX-Hepworth

d1 (mm)	d2 (mm)	Code	SP	Weight (kg)	d (mm)	L (mm)
16	20	<b>761 066 326</b>	10	0.005	15	54

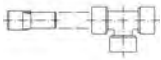

# Accessories



## Union nut

Suitable for flange or union nut

d (mm)	G (inch)	Code	SP	Weight (kg)
16	1	<b>761 066 188</b>	130	0.090
20	1 ¼	<b>761 066 100</b>	140	0.083
25	1 ½	<b>761 066 101</b>	80	0.104
32	2	<b>761 066 102</b>	0	0.142
40	2 ½	<b>761 066 103</b>	0	0.226
50	2 ¾	<b>761 066 104</b>	0	0.261
63	3 ½	<b>761 066 105</b>	0	0.334



## EPDM O-Ring

Quality suitable for potable water

d (mm)	Code	SP	Weight (kg)	d1 (mm)	D (mm)	H (mm)
16	<b>761 066 558</b>	1	0.002	19	26	4
20	<b>761 066 124</b>	1	0.002	23	31	4
25	<b>761 066 125</b>	1	0.001	28	35	4
32	<b>761 066 126</b>	1	0.001	36	43	4
40	<b>761 066 127</b>	1	0.004	44	55	5
50	<b>761 066 128</b>	1	0.001	53	64	5
63	<b>761 066 129</b>	1	0.002	69	80	5
75	<b>761 070 036</b>	1	0.007	82	93	5
90	<b>761 070 037</b>	1	0.008	101	112	5
110	<b>761 070 038</b>	1	0.016	120	134	7

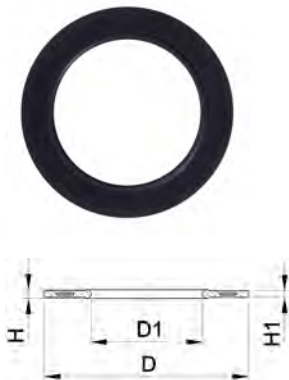

## Profile flange gasket metric For flange adaptors without chamfer

### Model:

- For flange adaptor No. 27 79 85 PP-H SDR11 without chamfer
- Profile Gasket with carbon steel insert (type G-ST-P/K)
- Hardness: 70° shore **EPDM**, 75° shore **FPM**

d (mm)	DN (mm)	PN (bar)	EPDM Code	SP	Weight (kg)	FPM Code	SP	Weight (kg)	D (mm)	D1 (mm)	H (mm)	H1 (mm)
20	15	16	<b>748 440 706</b>	1	0.009	<b>749 440 706</b>	1	0.013	51	20	4	3
25	20	16	<b>748 440 707</b>	1	0.015	<b>749 440 707</b>	1	0.014	61	22	4	3
32	25	16	<b>748 440 708</b>	1	0.013	<b>749 440 708</b>	1	0.019	71	28	4	3
40	32	16	<b>748 440 709</b>	1	0.019	<b>749 440 709</b>	1	0.026	82	40	4	3
50	40	16	<b>748 440 710</b>	1	0.029	<b>749 440 710</b>	1	0.039	92	46	4	3
63	50	16	<b>748 440 711</b>	1	0.041	<b>749 440 711</b>	1	0.050	107	58	5	4
75	65	16	<b>748 440 712</b>	1	0.053	<b>749 440 712</b>	1	0.082	127	69	5	4
90	80	16	<b>748 440 713</b>	1	0.064	<b>749 440 713</b>	1	0.083	142	84	5	4



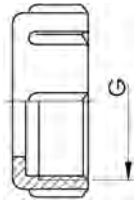

### Union nut

Suitable for flange adaptor and union

<b>d</b> (mm)	<b>G</b> (inch)	<b>Code</b>	<b>SP</b>	<b>Weight</b> (kg)
16	1	<b>761 066 980</b>	10	0.120
20	1 ¼	<b>761 066 971</b>	10	0.090
25	1 ½	<b>761 066 972</b>	10	0.110
32	2	<b>761 066 973</b>	10	0.130
40	2 ½	<b>761 066 974</b>	10	0.180
50	2 ¾	<b>766 066 975</b>	10	0.210
63	3 ½	<b>766 066 976</b>	2	0.280



# INSTAFLEX

## Pipe Outlets





### Single pipe outlet 1/2"

Not for prewall and wood-mounting installations

d (mm)	Rp (inch)	Code	SP	Weight (kg)	H (mm)	z (mm)
16	1/2	<b>760 869 914</b>	10	0.242	48	28
20	1/2	<b>760 856 021</b>	1	0.330	48	28

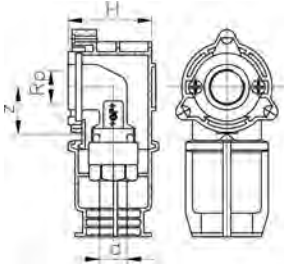

### Single pipe outlet 3/4"

d (mm)	Rp (inch)	Code	SP	Weight (kg)	H (mm)	L (mm)	B (mm)	z (mm)
20	3/4	<b>760 856 022</b>	1	0.350	46	70	50	28

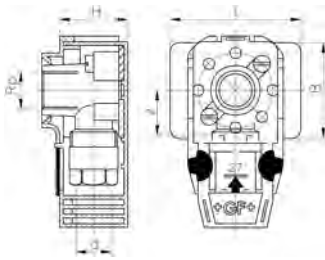

### Dual pipe outlet 1/2"

Not for prewall and wood-mounting installations

d1 (mm)	d2 (mm)	Rp (inch)	Code	SP	Weight (kg)	H (mm)	L (mm)	z1 (mm)	z2 (mm)
16	16	1/2	<b>760 856 023</b>	10	0.489	48	40	67	67
16	20	1/2	<b>760 856 027</b>	1	0.528	48	40	67	69
20	16	1/2	<b>760 856 029</b>	1	0.524	48	40	69	67
20	20	1/2	<b>760 856 025</b>	1	0.583	48	40	69	69

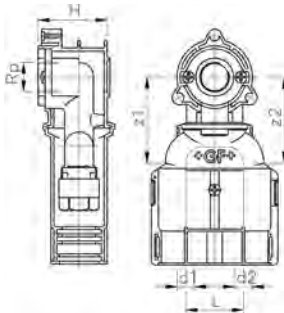



### Single pipe outlet - flange

Screw 760 856 040, self tapping M6 x 16  
\* for GIS wall mounting

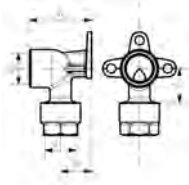

	d (mm)	Rp (inch)	Code	SP	Weight (kg)	H (mm)	H1 (mm)	z (mm)
	16	½	<b>760 853 013</b>	10	0.180	44	22	28
	16	½	<b>760 856 036</b>	2	0.279	60	22	28
	16	½	<b>760 856 037</b>	2	0.319	80	22	28
*	16	½	<b>760 856 043</b>	2	0.333	100	22	28
	20	½	<b>760 854 682</b>	10	0.213	44	25	28
	20	¾	<b>760 853 038</b>	1	0.313	44	25	28



### Dual pipe outlet - flange

Screw 760 856 040, self tapping M6 x 16  
\* for GIS wall mounting

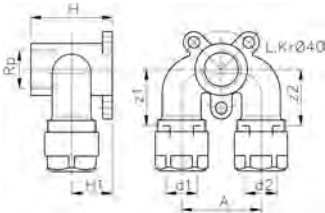

	d1 (mm)	d2 (mm)	Rp (inch)	Code	SP	Weight (kg)	H (mm)	H1 (mm)	z1 (mm)	z2 (mm)	A (mm)
	16	16	½	<b>760 853 059</b>	1	0.380	44	22	30	30	40
*	16	16	½	<b>760 856 045</b>	1	0.385	100	22	30	30	40
	20	20	½	<b>760 869 902</b>	1	0.439	44	25	32	32	40



### Dual pipe outlet - flange

Screw 760 856 040, self tapping M6 x 16

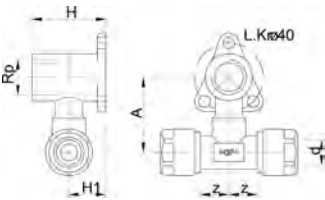

	d (mm)	Rp (inch)	Code	SP	Weight (kg)	H (mm)	H1 (mm)	z (mm)
	16	½	<b>760 853 014</b>	10	0.344	44	22	19



### Single pipe outlet - mounting flange

Screw 760 856 040, self tapping M6 x 16  
\* on request

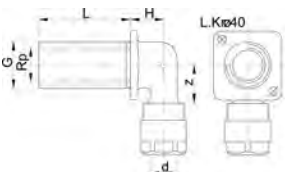

	d (mm)	Rp (inch)	G (inch)	Code	SP	Weight (kg)	L (mm)	H (mm)	z (mm)
	16	½	¾	<b>760 856 041</b>	2	0.236	30	20	26
*	16	½	¾	<b>760 856 050</b>	2	0.254	42	20	26
*	16	½	¾	<b>760 869 906</b>	2	0.273	55	20	26



### Single pipe outlet - mounting flange

Screw 760 856 040, self tapping M6 x 16

d (mm)	Rp (inch)	Code	SP	Weight (kg)	D (mm)	L (mm)	H (mm)	z (mm)
16	1/2	<b>760 869 904</b>	2	0.222	27	20	22	26

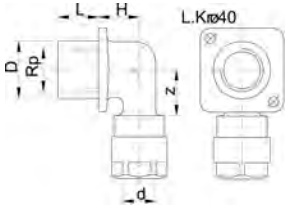

### Fastening set

Appropriate to outlet joint - male thread  
Consists of: Union nut washer, seal  
From the INSTAFLEX range

G (inch)	Code	SP	Weight (kg)
3/4	<b>760 854 699</b>	10	0.031

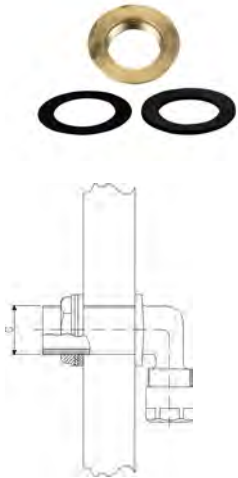

### Rubber isolator for pipe outlets

Suitable for dual pipe outlets

H (mm)	Code	SP	Weight (kg)	z (mm)
9	<b>760 856 205</b>	20	0.007	3

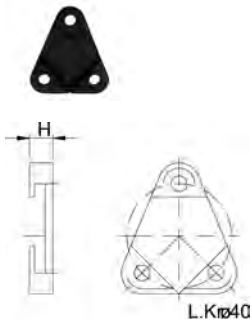

### Pipe outlet GIS

Consisting: 1 Distance plate, 2 Rubber isolator, 6 Screws, 2 Single pipe outlet d16 - 1/2"

L2 (mm)	L3 (mm)	Code	SP	Weight (kg)
73	153	<b>760 856 010</b>	1	0.933

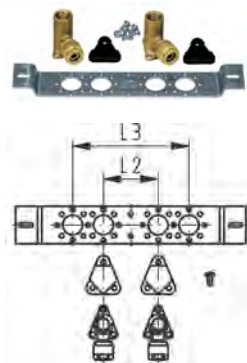



### Pipe outlet for flushing cistern Meplafix 90°

Incl. protection cap

d (mm)	Code	SP	Weight (kg)	h (mm)	z (mm)
16	<b>760 856 049</b>	1	0.163	43	21

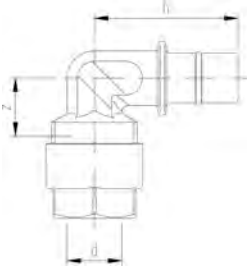

### Single pipe outlet

With fastening set

d (mm)	Rp (inch)	Code	SP	Weight (kg)	G (inch)	H (mm)	L (mm)	z (mm)
16	½	<b>760 856 011</b>	5	0.243	1	22	14	26

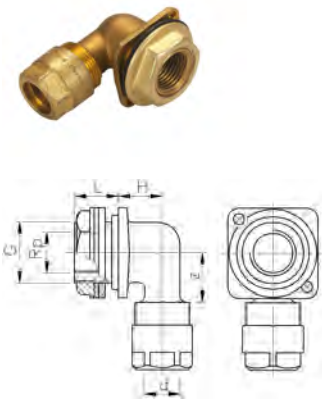

### Dual pipe outlet - not interchangeable

With fastening set

d (mm)	Rp (inch)	Code	SP	Weight (kg)	G (inch)	L (mm)	H (mm)	z (mm)
16	½	<b>760 856 013</b>	5	0.340	1	14	22	26

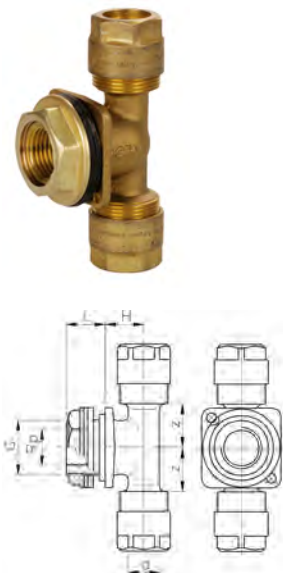



### Single pipe outlet 90°

\* available as long as stock exist

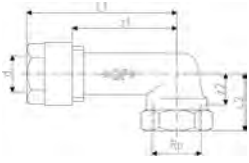

	d (mm)	Rp (inch)	Code	SP	Weight (kg)	L1 (mm)	L2 (mm)	z1 (mm)	z2 (mm)
	16	1/2	<b>760 854 882</b>	5	0.210	67	30	46	17
	20	1/2	<b>760 854 883</b>	5	0.225	74	30	48	17
	20	3/4	<b>760 854 884</b>	5	0.235	76	30	50	16
*	25	3/4	<b>760 854 886</b>	2	0.455	93	30	59	16

### Wall inlet plug

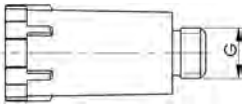

G (inch)	Code	SP	Weight (kg)
1/2	<b>760 853 297</b>	10	0.088

### Fastening sleeve

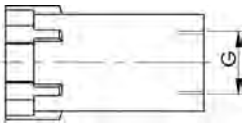

G (inch)	Code	SP	Weight (kg)
1/2	<b>760 853 298</b>	10	0.050

### Mounting bolt







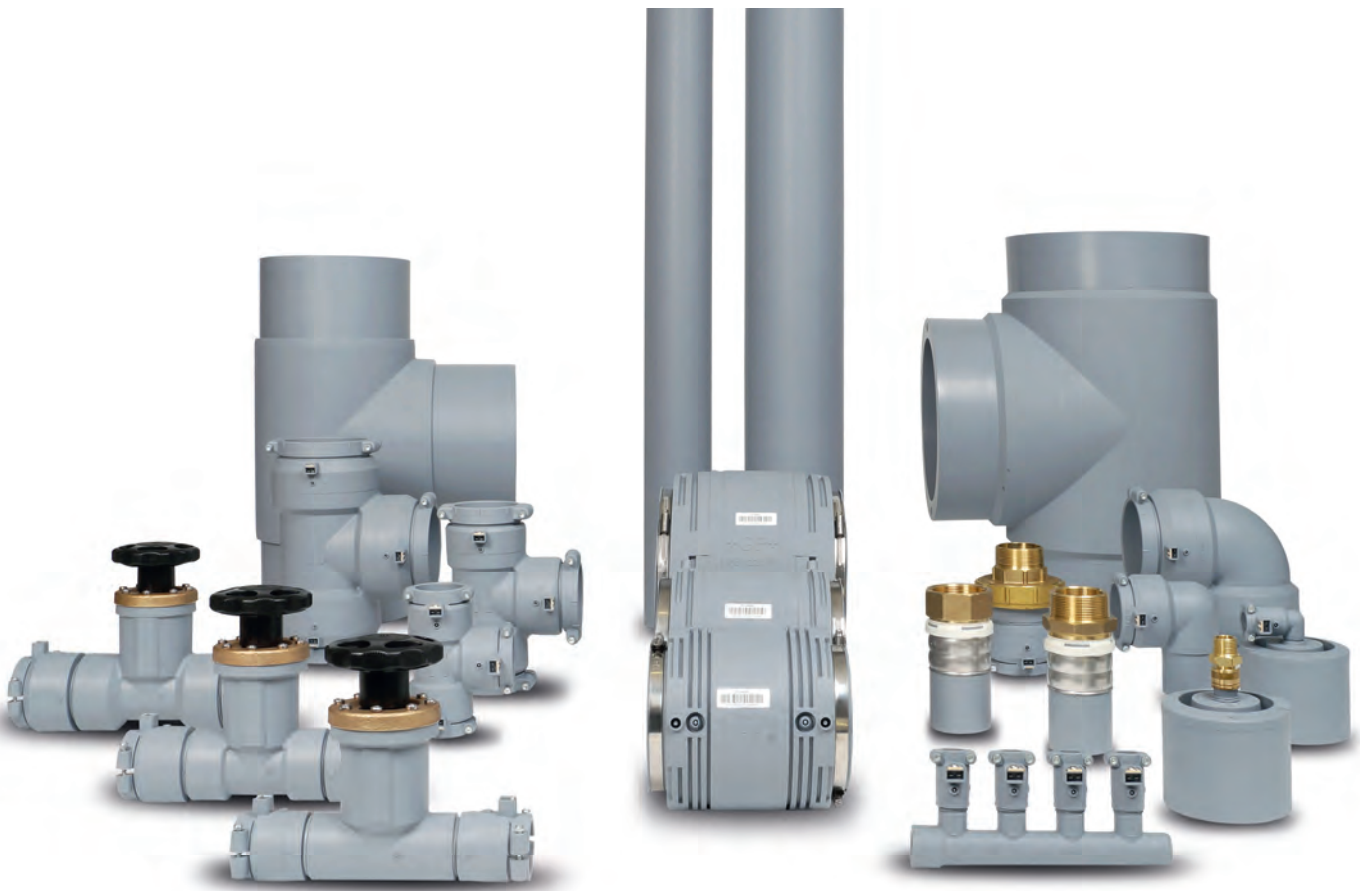

G (inch)	Code	SP	Weight (kg)
1/2	<b>760 853 291</b>	5	0.138

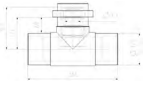
# INSTAFLEX

Electro fusion jointing HWS



	Fittings	86
	Segment fittings	91
	Manifolds	93
	Flange adapters	94
	Special reducers	95
	Accessories	98
	Flanges	99

# Electro fusion HWS d16-d110

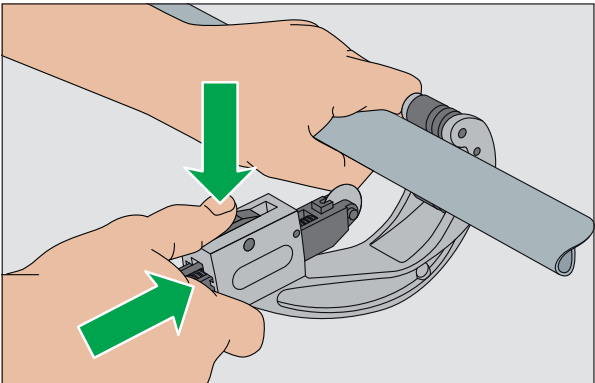

1

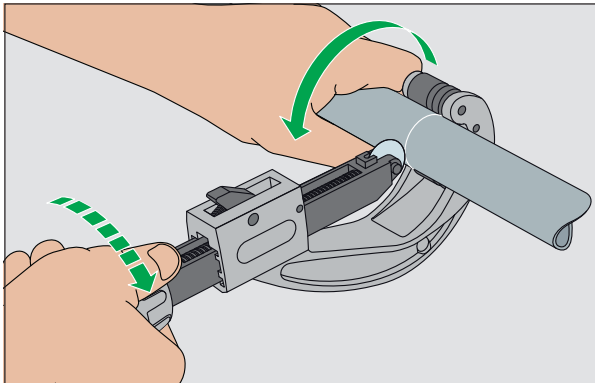

2

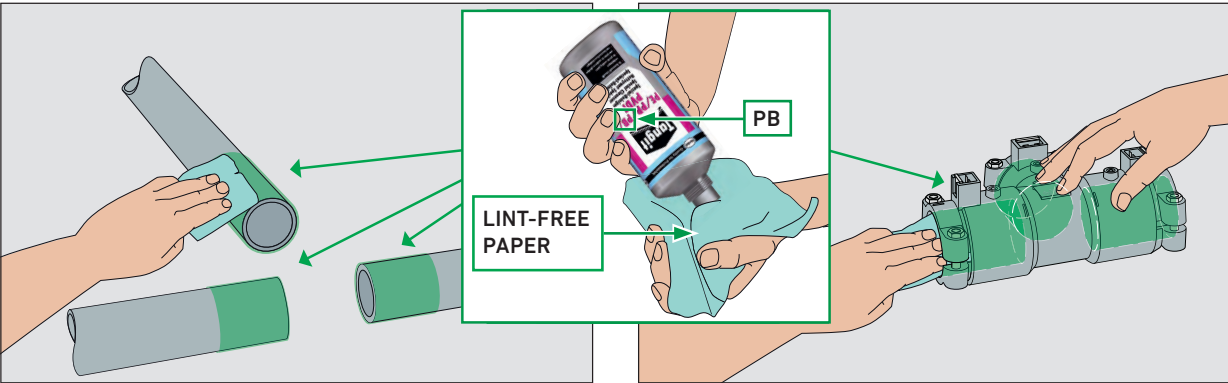

3

4

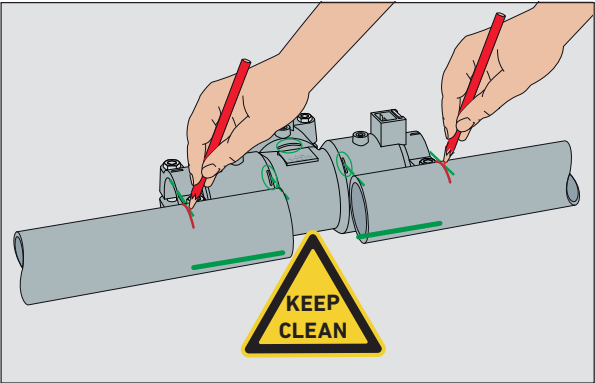

5

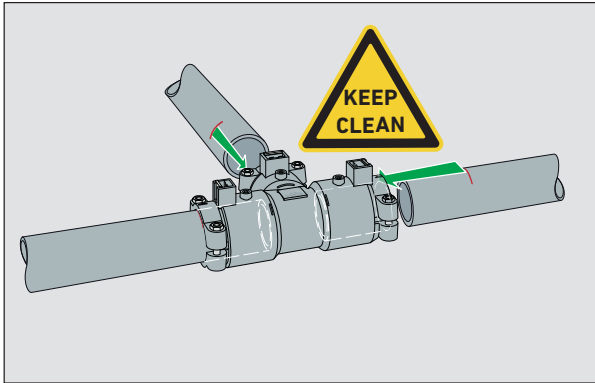

6

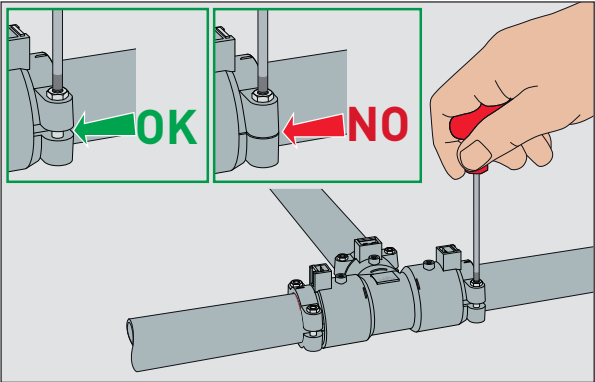

7

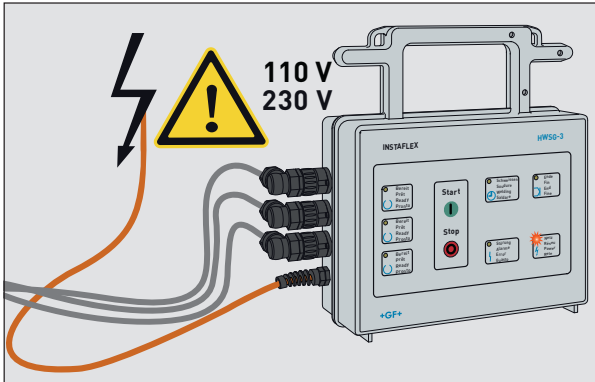

8

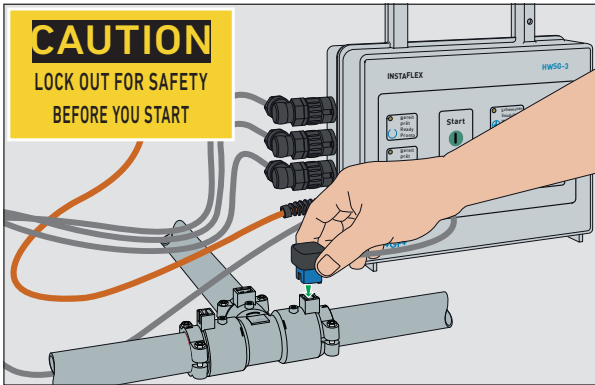

9

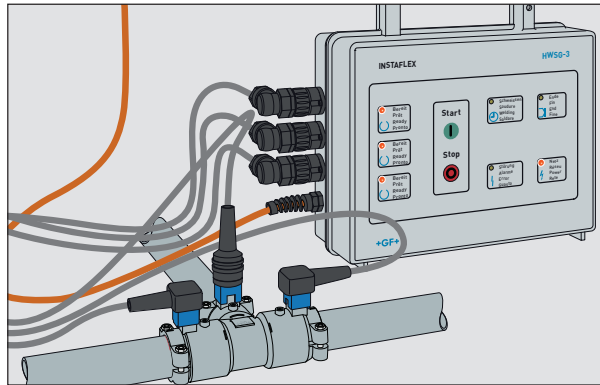

10

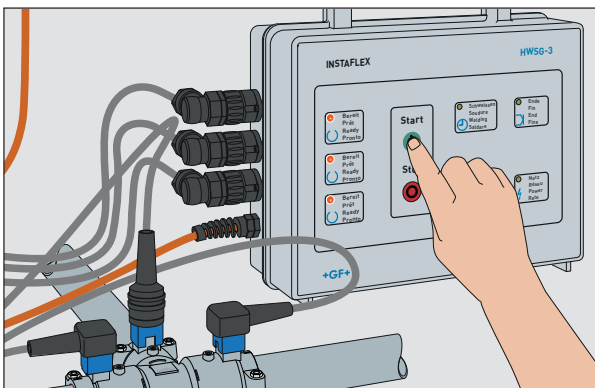

11

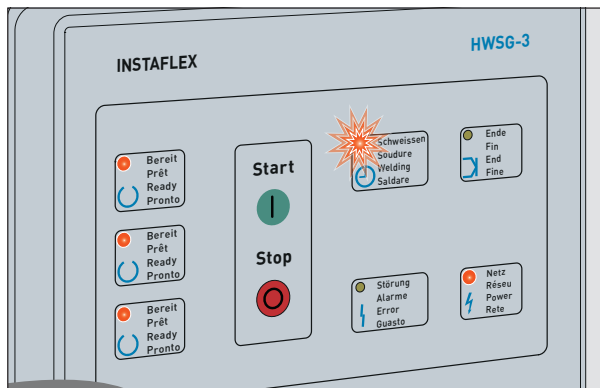

12

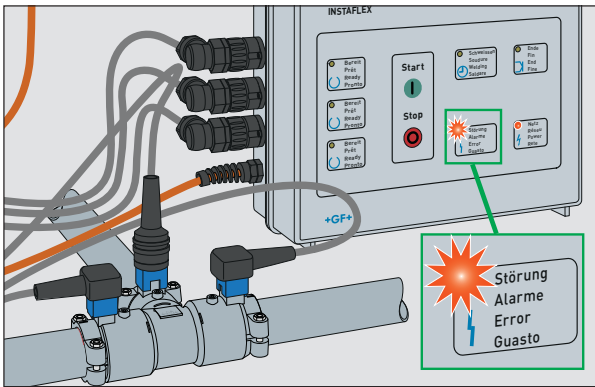

13

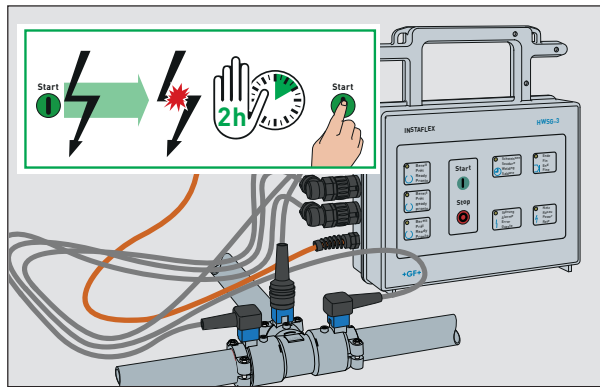

14

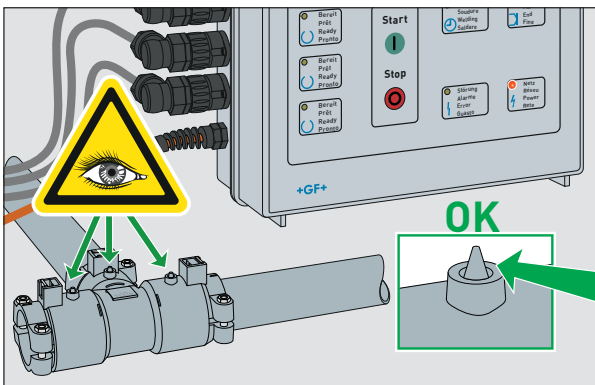

15

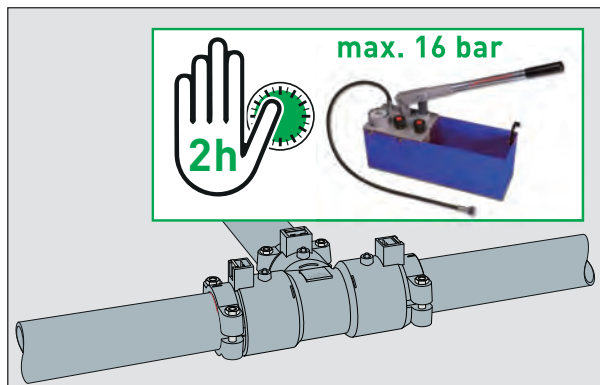

16

# Electro fusion d125/d160/d225

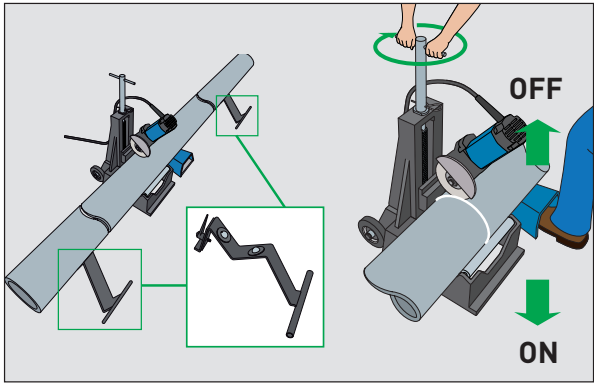

1

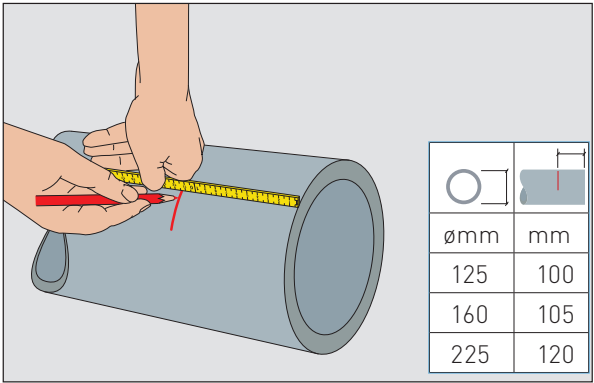

2

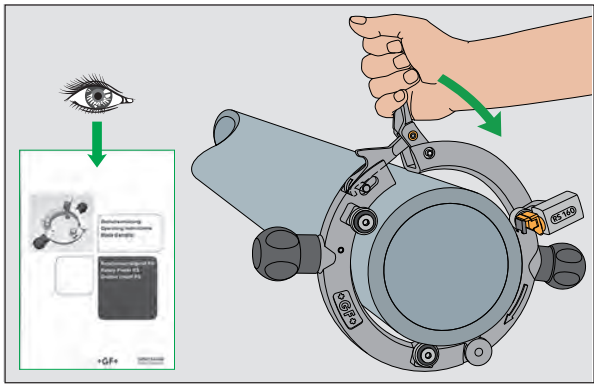

3

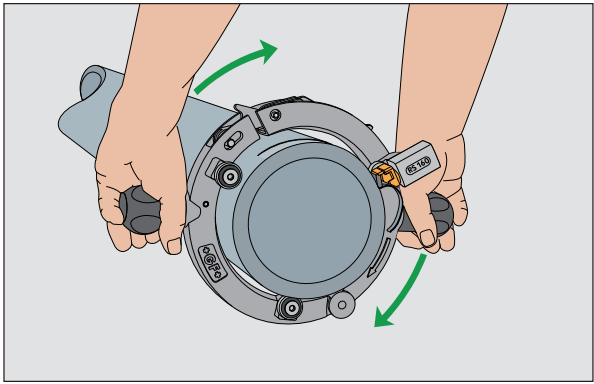

4

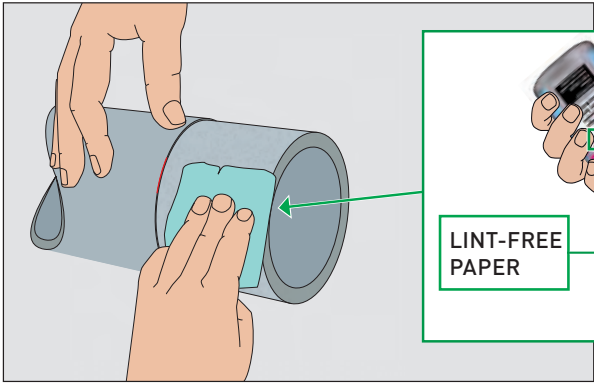

5

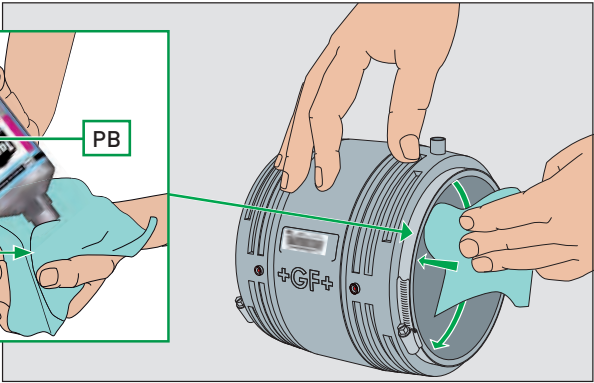

6

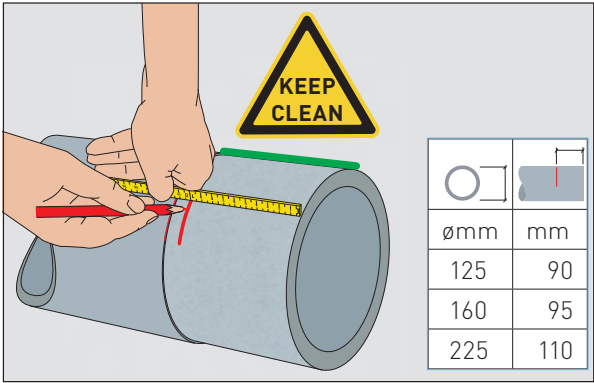

7

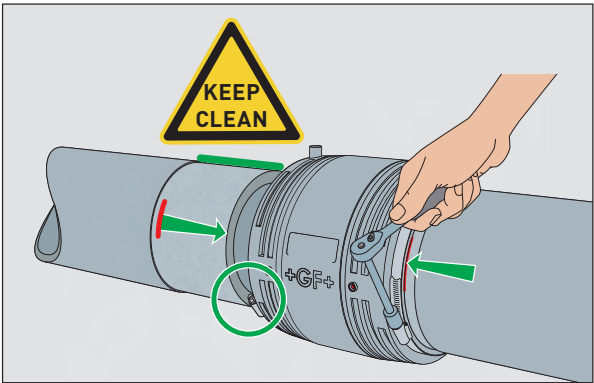

8

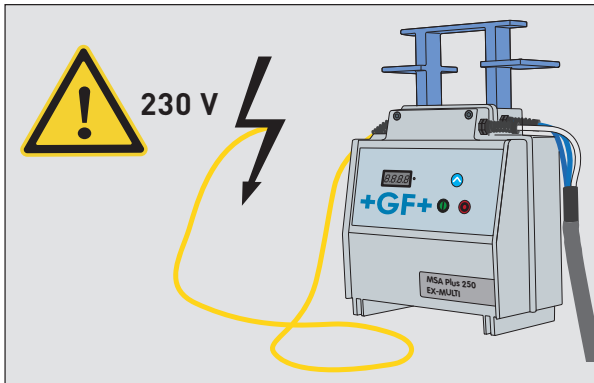

9

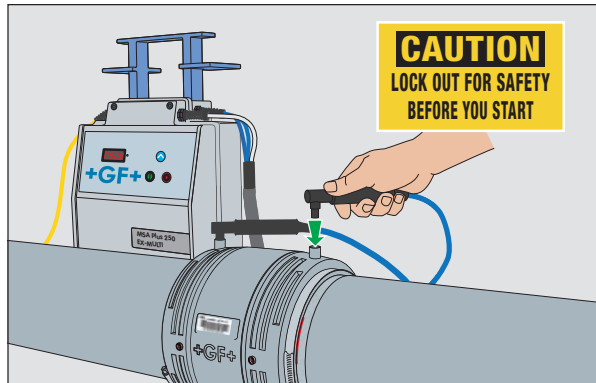

10



11

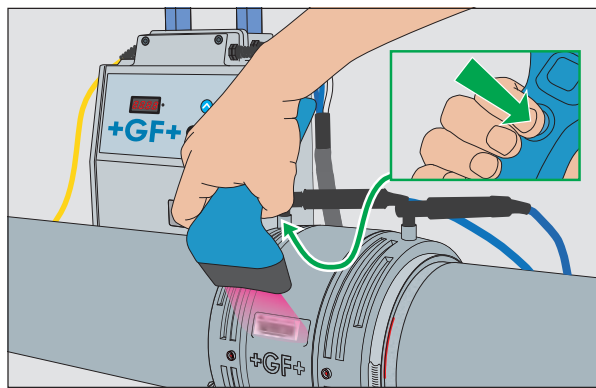

12

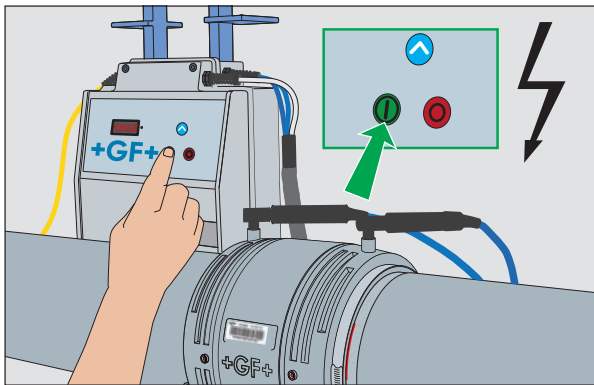

13

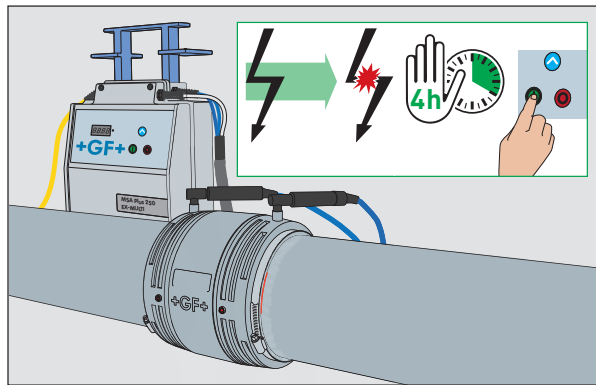

14

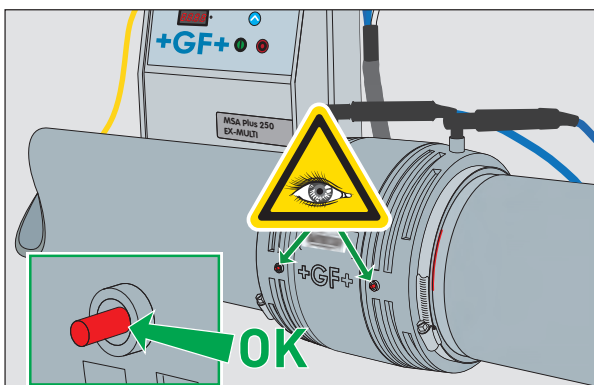

15

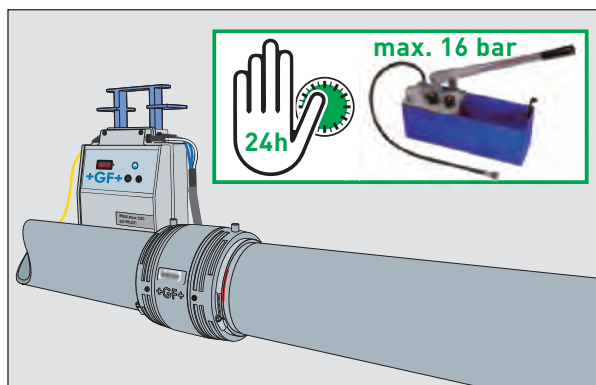

16



# Fittings

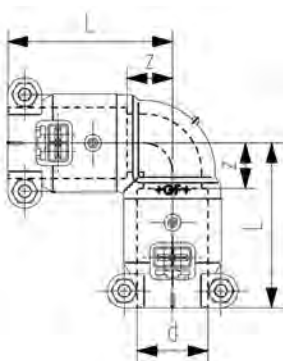

## Electro fusion elbow 90°

d (mm)	Code	SP	Weight (kg)	L (mm)	z (mm)
16	<b>761 069 214</b>	1	0.023	47	10
20	<b>761 069 215</b>	1	0.027	54	14
25	<b>761 069 216</b>	1	0.039	58	16
32	<b>761 069 217</b>	1	0.079	60	18
40	<b>761 069 218</b>	1	0.128	69	22
50	<b>761 069 219</b>	1	0.206	78	29
63	<b>761 069 220</b>	1	0.328	86	36
75	<b>761 069 221</b>	1	0.515	112	45
90	<b>761 069 222</b>	1	0.811	127	54
110	<b>761 069 223</b>	1	1.330	146	66

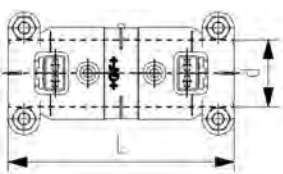

## Electro fusion coupler

Suitable as sliding coupling

d (mm)	Code	SP	Weight (kg)	L (mm)
16	<b>761 069 200</b>	1	0.023	76
20	<b>761 069 201</b>	1	0.027	80
25	<b>761 069 202</b>	1	0.041	85
32	<b>761 069 203</b>	1	0.053	85
40	<b>761 069 204</b>	1	0.084	95
50	<b>761 069 205</b>	1	0.121	99
63	<b>761 069 206</b>	1	0.184	102
75	<b>761 069 265</b>	1	0.317	134
90	<b>761 069 266</b>	1	0.519	147
110	<b>761 069 267</b>	1	0.766	160

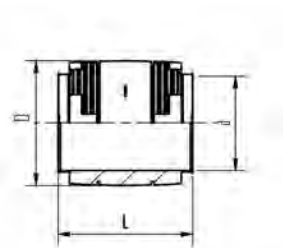

## Electro fusion coupler - PN16

d (mm)	Code	SP	Weight (kg)	L (mm)
125	<b>761 069 555</b>	1	1.500	186
160	<b>761 069 556</b>	1	2.021	190
225	<b>761 069 557</b>	1	4.472	220

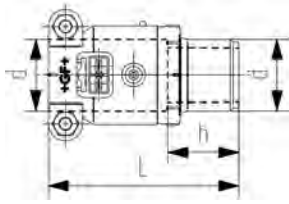

### Electro fusion adaptor

Transition to socket fusion - HMS

d (mm)	Code	SP	Weight (kg)	L (mm)	h (mm)
16	<b>761 069 207</b>	1	0.026	60	23
20	<b>761 069 208</b>	1	0.017	61	22
25	<b>761 069 209</b>	1	0.026	67	25
32	<b>761 069 210</b>	1	0.037	71	29
40	<b>761 069 211</b>	1	0.060	79	32
50	<b>761 069 212</b>	1	0.095	85	36
63	<b>761 069 213</b>	1	0.151	94	43

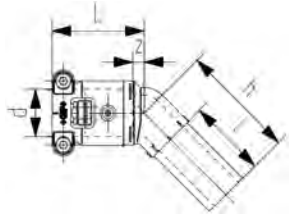

### Elbow 45° socket-spigot

d (mm)	Code	SP	Weight (kg)	L (mm)	l (mm)	h (mm)	z (mm)
16	<b>761 069 447</b>	1	0.014	44	38	50	6
20	<b>761 069 448</b>	1	0.030	46	40	54	7
25	<b>761 069 449</b>	1	0.042	50	42	57	8
32	<b>761 069 450</b>	1	0.059	51	42	60	9
40	<b>761 069 451</b>	1	0.098	58	47	67	11
50	<b>761 069 452</b>	1	0.156	63	49	75	14
63	<b>761 069 453</b>	1	0.242	68	51	79	17

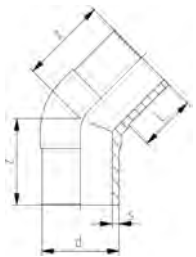

### Elbow 45°

d (mm)	Code	SP	Weight (kg)	L (mm)	z (mm)
125	<b>761 065 261</b>	1	1.246	92	140
160	<b>761 065 262</b>	1	2.379	102	162
225	<b>761 065 263</b>	1	6.065	122	200

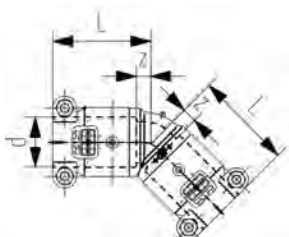

### Electro fusion elbow 45°

d (mm)	Code	SP	Weight (kg)	L (mm)	z (mm)
16	<b>761 069 227</b>	1	0.033	44	6
20	<b>761 069 228</b>	1	0.027	46	7
25	<b>761 069 229</b>	1	0.039	50	8
32	<b>761 069 230</b>	1	0.059	51	9
40	<b>761 069 231</b>	1	0.070	58	11
50	<b>761 069 232</b>	1	0.147	63	14
63	<b>761 069 233</b>	1	0.275	68	17
75	<b>761 069 234</b>	1	0.451	88	21
90	<b>761 069 235</b>	1	0.700	98	25
110	<b>761 069 236</b>	1	1.098	111	31

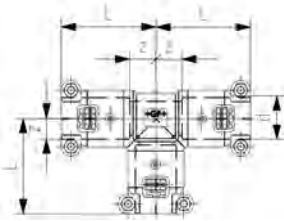

### Electro fusion T-piece 90°- equal

d (mm)	Code	SP	Weight (kg)	L (mm)	z (mm)
16	<b>761 069 237</b>	1	0.053	47	10
20	<b>761 069 238</b>	1	0.067	54	14
25	<b>761 069 239</b>	1	0.089	58	16
32	<b>761 069 240</b>	1	0.116	60	18
40	<b>761 069 241</b>	1	0.185	69	22
50	<b>761 069 242</b>	1	0.290	78	29
63	<b>761 069 243</b>	1	0.452	86	36
75	<b>761 069 244</b>	1	0.747	112	45
90	<b>761 069 245</b>	1	0.890	127	54
110	<b>761 069 246</b>	1	1.884	146	66



### Tee 90° - equal

d (mm)	Code	SP	Weight (kg)	L (mm)	z (mm)
125	<b>761 065 255</b>	1	2.397	93	183
160	<b>761 065 256</b>	1	4.312	102	210
225	<b>761 065 257</b>	1	11.984	122	270

### Electro fusion T-piece 90° - reducer

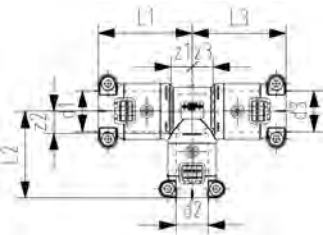

d1 (mm)	d2 (mm)	d3 (mm)	Code	SP	Weight (kg)	L1 (mm)	L2 (mm)	L3 (mm)	z1 (mm)	z2 (mm)	z3 (mm)
20	16	16	<b>761 069 249</b>	1	0.058	54	47	47	14	10	10
20	16	20	<b>761 069 250</b>	1	0.041	54	49	54	14	11	14
25	16	25	<b>761 069 251</b>	1	0.082	58	54	58	16	16	16
25	20	20	<b>761 069 256</b>	1	0.079	58	54	54	16	14	14
25	20	25	<b>761 069 252</b>	1	0.079	58	54	58	16	14	16
25	25	20	<b>761 069 257</b>	1	0.081	58	58	54	16	16	14
32	20	32	<b>761 069 253</b>	1	0.088	60	58	60	18	18	18
32	25	25	<b>761 069 258</b>	1	0.098	60	58	58	18	16	16
32	25	32	<b>761 069 254</b>	1	0.095	60	58	60	18	16	18
40	20	40	<b>761 069 259</b>	1	0.157	69	63	69	22	23	22
40	25	40	<b>761 069 255</b>	1	0.170	69	63	69	22	21	22
40	32	40	<b>761 069 260</b>	1	0.168	69	63	69	22	21	22
50	25	50	<b>761 069 261</b>	1	0.246	78	72	78	29	30	29
50	32	50	<b>761 069 262</b>	1	0.360	78	72	78	29	30	29
63	25	63	<b>761 069 263</b>	1	0.360	86	81	86	36	39	36
63	40	63	<b>761 069 264</b>	1	0.384	86	85	86	36	38	36



### Electro fusion adapter T-piece 90° - male thread

Electro fusion T-piece with transition to male thread  
Thread in DZR brass, UBA (Umwelt Bundesamt, Germany) conform  
EPDM sealing hot and cold water approved

d	R	Code	SP	Weight	L1	L2	z1	z2
(mm)	(inch)			(kg)	(mm)	(mm)	(mm)	(mm)
25	¾	<b>761 069 738</b>	1	0.177	58	88	16	73
32	1	<b>761 069 739</b>	1	0.246	60	97	18	80

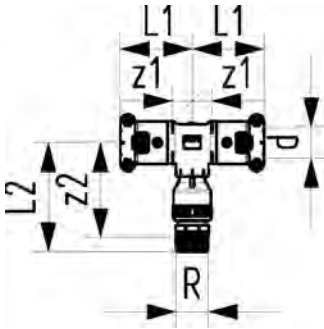

### Electro fusion - end cap



d	Code	SP	Weight	L
(mm)			(kg)	(mm)
16	<b>761 069 270</b>	1	0.022	67
20	<b>761 069 271</b>	1	0.025	70
25	<b>761 069 272</b>	1	0.036	77
32	<b>761 069 273</b>	1	0.054	83
40	<b>761 069 274</b>	1	0.095	95
50	<b>761 069 275</b>	1	0.153	104
63	<b>761 069 276</b>	1	0.265	116

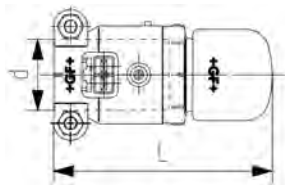

### Electro fusion - reducer



d1	d2	Code	SP	Weight	l	h	z
(mm)	(mm)			(kg)	(mm)	(mm)	(mm)
20	16	<b>761 069 277</b>	1	0.023	40	83	45
25	16	<b>761 069 278</b>	1	0.026	42	83	46
25	20	<b>761 069 279</b>	1	0.026	42	86	47
32	16	<b>761 069 457</b>	1	0.033	42	86	48
32	20	<b>761 069 280</b>	1	0.030	42	84	45
32	25	<b>761 069 281</b>	1	0.038	42	89	47
40	20	<b>761 069 458</b>	1	0.055	47	102	62
40	25	<b>761 069 459</b>	1	0.060	47	104	62
40	32	<b>761 069 282</b>	1	0.060	47	95	53
50	20	<b>761 069 460</b>	1	0.070	49	102	62
50	25	<b>761 069 461</b>	1	0.075	49	104	62
50	32	<b>761 069 462</b>	1	0.075	49	95	53
50	40	<b>761 069 283</b>	1	0.091	49	103	56
63	20	<b>761 069 463</b>	1	0.096	51	102	62
63	25	<b>761 069 464</b>	1	0.109	51	104	62
63	32	<b>761 069 284</b>	1	0.101	51	95	53
63	40	<b>761 069 465</b>	1	0.121	51	103	56
63	50	<b>761 069 285</b>	1	0.141	51	106	57
75	63	<b>761 069 286</b>	1	0.232	67	129	78
90	63	<b>761 069 287</b>	1	0.289	74	128	77

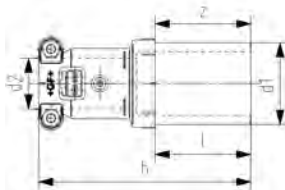
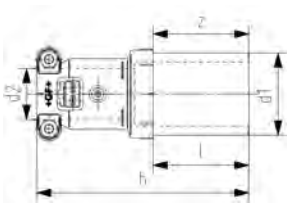

table continued on the next page



d1 (mm)	d2 (mm)	Code	SP	Weight (kg)	l (mm)	h (mm)	z (mm)
90	75	<b>761 069 288</b>	1	0.354	74	143	76
110	63	<b>761 069 289</b>	1	0.414	80	135	84
110	75	<b>761 069 290</b>	1	0.464	80	150	83
110	90	<b>761 069 291</b>	1	0.576	80	165	92



### Reducer

d1 (mm)	d2 (mm)	Code	SP	Weight (kg)	L1 (mm)	L2 (mm)	z (mm)
125	110	<b>761 065 267</b>	1	0.729	92	85	215
160	125	<b>761 065 268</b>	1	1.263	102	92	245
225	160	<b>761 065 269</b>	1	2.800	122	102	280

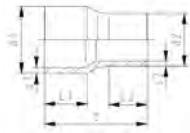

### Sliding sleeves

\* on request

	d (mm)	Code	SP	Weight (kg)	L (mm)	z (mm)
*	20	<b>761 069 623</b>	1	0.093	168	90
*	25	<b>761 069 624</b>	1	0.168	208	124
*	32	<b>761 069 625</b>	1	0.219	190	106
*	40	<b>761 069 626</b>	1	0.362	206	112

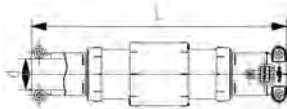

### Bracket clamp

\* on request

	d (mm)	Code	SP	Weight (kg)
*	16	<b>761 069 490</b>	10	0.016
*	20	<b>761 069 491</b>	10	0.018
*	25	<b>761 069 492</b>	10	0.023
*	32	<b>761 069 493</b>	6	0.030
*	40	<b>761 069 494</b>	6	0.050
*	50	<b>761 069 495</b>	6	0.073
*	63	<b>761 069 496</b>	6	0.102
*	75	<b>761 069 497</b>	6	0.166
*	90	<b>761 069 498</b>	4	0.244
*	110	<b>761 069 499</b>	4	0.380

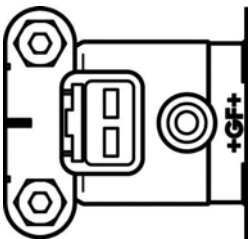

## Segment fittings

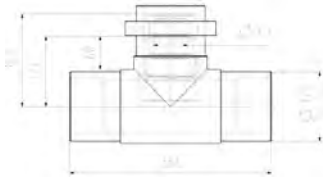

### T-piece - reducer / flange

Prefabricated elbow with short end for electro fusion socket  
GF customized quality, pre-peeled, swiss made  
Single packed in plastic bags  
\* on request

	d1 (mm)	d2 (mm)	d3 (mm)	Code	SP Weight (kg)	L1 (mm)	L2 (mm)
*	125	63	125	<b>761 065 297</b>	0	0.001	167 366
*	125	75	125	<b>761 065 302</b>	0	5.540	173 366
*	125	110	125	<b>761 065 301</b>	0	0.001	180 420
*	160	125	160	<b>761 065 313</b>	0	5.784	340 420
*	160	75	160	<b>761 065 299</b>	0	17.920	208 420
*	160	90	160	<b>761 065 300</b>	0	0.001	216 420

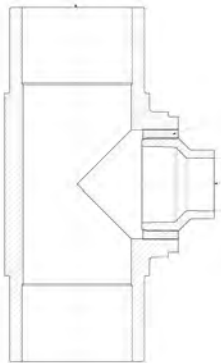

### T-piece - reducer

Prefabricated elbow with short end for electro fusion socket  
GF customized quality, pre-peeled, swiss made  
Single packed in plastic bags  
\* on request

	d1 (mm)	d2 (mm)	d3 (mm)	Code	SP Weight (kg)	L1 (mm)	L2 (mm)
*	125	63	125	<b>761 070 263</b>	0	0.001	90 336
*	160	63	160	<b>761 070 264</b>	0	0.001	120 420

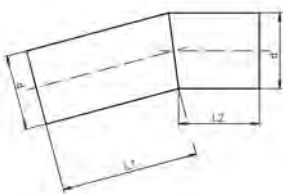

### Elbow 15°

Prefabricated elbow with short and long ends for electro fusion fittings  
GF customized quality, pre-peeled, swiss made  
Single packed in plastic bags  
\* on request

	d (mm)	Code	SP Weight (kg)	L1 (mm)	L2 (mm)
*	63	<b>761 069 589</b>	1	0.306	180 65
*	75	<b>761 069 590</b>	1	0.576	236 80
*	90	<b>761 069 591</b>	1	0.824	265 85
*	110	<b>761 069 592</b>	1	1.340	292 100

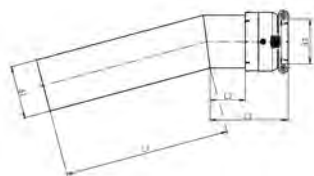

### Elbow 15°

Prefabricated elbow with short end for electro fusion socket  
GF customized quality, pre-peeled, swiss made  
Single packed in plastic bags  
\* on request

	d-d (mm)	Code	SP Weight (kg)	L1 (mm)	L2 (mm)	L3 (mm)
*	75 - 63	<b>761 069 599</b>	1	0.306	236	50 111
*	90 - 75	<b>761 069 600</b>	1	0.500	265	55 125
*	110 - 90	<b>761 069 601</b>	1	0.706	292	60 145

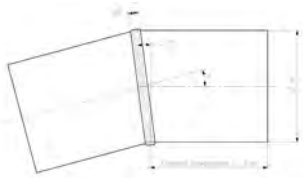

### Elbow 15°

Prefabricated elbow with two short ends for electro fusion fittings  
 GF customized quality, pre-peeled, swiss made  
 Single packed in plastic bags  
 \* on request

	d (mm)	Code	SP	Weight (kg)	L1 (mm)
*	90	<b>761 069 662</b>	1	0.405	95
*	110	<b>761 065 311</b>	1	0.647	100
*	125	<b>761 065 304</b>	1	0.905	110
*	160	<b>761 065 305</b>	1	1.590	115
*	225	<b>761 065 307</b>	1	6.348	130

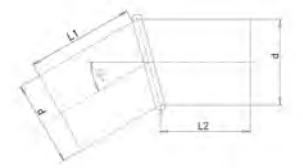

### Elbow 30°

Prefabricated elbow with two short ends for electro fusion fittings  
 GF customized quality, pre-peeled, swiss made  
 Single packed in plastic bags  
 \* on request

	d (mm)	Code	SP	Weight (kg)	L1 (mm)
*	90	<b>760 069 663</b>	1		95
*	110	<b>761 065 312</b>	0	0.641	100
*	125	<b>761 065 308</b>	1	0.971	110
*	160	<b>761 065 309</b>	1	1.723	115
*	225	<b>761 065 310</b>	1		130

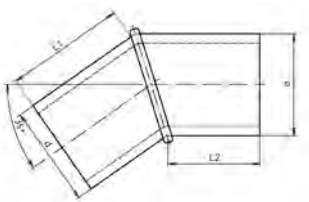

### Elbow 35°

Prefabricated elbow with two short ends for electro fusion fittings  
 GF customized quality, pre-peeled, swiss made  
 Single packed in plastic bags  
 \* on request

	d (mm)	Code	SP	Weight (kg)	L1 (mm)
*	110	<b>761 069 665</b>	1	1.500	100



# Manifolds



## Polybutene Manifold for electro fusion

Electro fusion connections

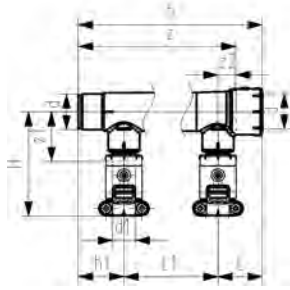

	d (mm)	d1 (mm)	Code	SP	Weight (kg)	L (mm)	L1 (mm)	H (mm)	h (mm)	h1 (mm)	z (mm)	z1 (mm)	z2 (mm)
single	25	16	<b>761 066 250</b>	1	0.040	31	0	60	63	32	45	36	13
single	25	20	<b>761 066 251</b>	1	0.050	39	0	64	78	39	60	35	21
double	25	16	<b>761 066 252</b>	1	0.074	31	45	60	108	32	90	36	13
triple	25	16	<b>761 066 253</b>	1	0.112	31	45	60	153	32	135	36	13
4 fold	25	16	<b>761 066 254</b>	1	0.144	31	45	60	198	32	180	36	13

### Raccordement à gauche

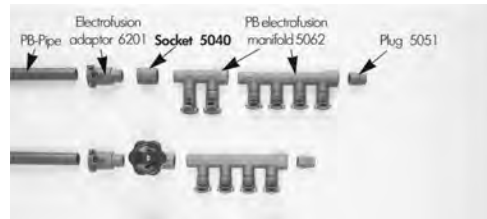
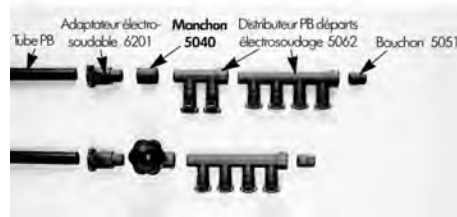

### Raccordement à droite

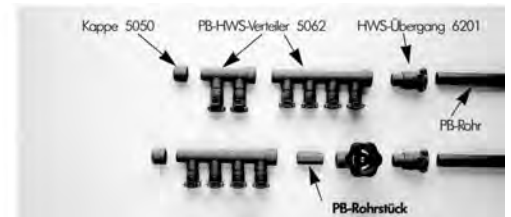
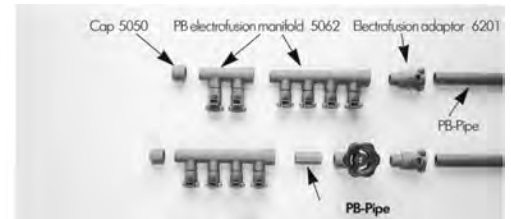
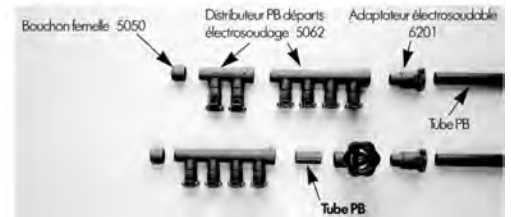

## Flange adapters



### Flange adaptor flat with groove and spigots for electro fusion

Suitable for flange or union nut  
Including EPDM O-Ring, quality suitable for potable water  
\* on request

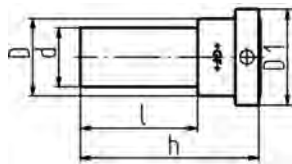

	<b>d</b> (mm)	<b>Code</b>	<b>SP</b>	<b>Weight</b> (kg)	<b>D</b> (mm)	<b>D1</b> (mm)	<b>l</b> (mm)	<b>h</b> (mm)
*	16	<b>761 069 306</b>	5	0.011	22	29	45	68
*	20	<b>761 069 307</b>	1	0.018	27	34	47	70
*	25	<b>761 069 308</b>	1	0.023	33	41	50	76
*	32	<b>761 069 309</b>	1	0.039	41	50	50	78
*	40	<b>761 069 310</b>	1	0.061	50	61	56	88
*	50	<b>761 069 311</b>	1	0.096	61	73	58	93
*	63	<b>761 069 312</b>	1	0.168	76	90	60	98
*	75	<b>761 069 313</b>	1	0.343	90	106	118	158
*	90	<b>761 069 314</b>	1	0.515	109	125	125	172
*	110	<b>761 069 315</b>	1	0.840	131	150	131	186



### Flange adaptor flat with spigot for electro fusion

Suitable for flange or union nut  
\* on request

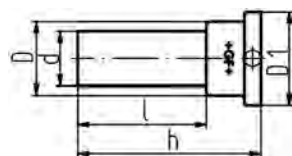

	<b>d</b> (mm)	<b>Code</b>	<b>SP</b>	<b>Weight</b> (kg)	<b>D</b> (mm)	<b>D1</b> (mm)	<b>l</b> (mm)	<b>h</b> (mm)
*	20	<b>761 069 321</b>	1	0.017	27	34	45	67
*	25	<b>761 069 322</b>	1	0.021	33	41	50	73
*	32	<b>761 069 323</b>	1	0.034	41	50	50	75
*	40	<b>761 069 324</b>	1	0.066	50	61	56	83
*	50	<b>761 069 325</b>	1	0.091	61	73	58	88
	63	<b>761 069 326</b>	1	0.172	76	90	60	93
	75	<b>761 069 327</b>	1	0.311	90	106	118	153
	90	<b>761 069 328</b>	1	0.469	109	125	125	167
	110	<b>761 069 329</b>	1	0.770	131	150	131	180



### Flange adaptor - flat

	<b>d</b> (mm)	<b>Code</b>	<b>SP</b>	<b>Weight</b> (kg)	<b>d1</b> (mm)	<b>d2</b> (mm)	<b>L</b> (mm)	<b>b</b> (mm)	<b>z</b> (mm)
	125	<b>761 065 264</b>	1	0.864	132	162	123	25	170
	160	<b>761 065 265</b>	1	1.667	176	218	147	25	200
	225	<b>761 065 266</b>	1	3.003	236	274	122	32	200

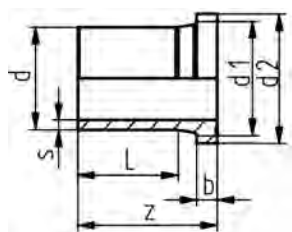

# Special reducers

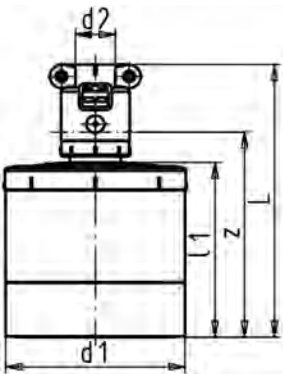

## Special reducer with adaptor

\* on request

	d1 (mm)	d2 (mm)	Code	SP	Weight (kg)	l (mm)	l1 (mm)	z (mm)
*	75	16	<b>761 069 604</b>	1	0.212	134	88	97
*	75	20	<b>761 069 605</b>	1	0.216	134	88	95
*	75	25	<b>761 069 606</b>	1	0.221	137	88	95
*	75	32	<b>761 069 607</b>	1	0.237	139	88	97
*	75	40	<b>761 069 608</b>	1	0.254	145	88	98
*	75	50	<b>761 069 609</b>	1	0.270	148	88	99
*	90	16	<b>761 069 610</b>	1	0.254	133	87	96
*	90	20	<b>761 069 611</b>	1	0.265	133	87	94
*	90	25	<b>761 069 612</b>	1	0.267	136	87	94
*	90	32	<b>761 069 613</b>	1	0.277	138	87	96
*	90	40	<b>761 069 614</b>	1	0.297	144	87	97
*	90	50	<b>761 069 615</b>	1	0.322	147	87	98
*	110	16	<b>761 069 518</b>	1	0.405	140	94	103
*	110	20	<b>761 069 519</b>	1	0.405	140	94	101
*	110	25	<b>761 069 520</b>	1	0.414	143	94	101
*	110	32	<b>761 069 521</b>	1	0.433	145	94	103
*	110	40	<b>761 069 522</b>	1	0.461	151	94	104
*	110	50	<b>761 069 523</b>	1	0.469	154	94	105

## Special reducer with transition on elbow

\* additional diameter on request

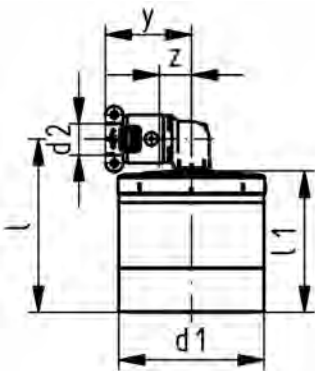

	d1 (mm)	d2 (mm)	Code	SP	Weight (kg)	l (mm)	l1 (mm)	z (mm)	y (mm)
*	75	20	<b>761 069 619</b>	1	0.228	109	88	14	54
*	75	25	<b>761 069 524</b>	1	0.235	111	88	16	58
*	75	32	<b>761 069 525</b>	1	0.249	115	88	18	60
*	75	40	<b>761 069 526</b>	1	0.300	121	88	22	96
*	75	50	<b>761 069 527</b>	1	0.326	127	88	29	78
*	90	20	<b>761 069 620</b>	1	0.273	108	87	14	54
*	90	25	<b>761 069 528</b>	1	0.283	110	87	16	58
*	90	32	<b>761 069 529</b>	1	0.300	114	87	18	60
*	90	40	<b>761 069 530</b>	1	0.350	120	87	22	69
*	90	50	<b>761 069 531</b>	1	0.415	126	87	29	78
*	110	20	<b>761 069 621</b>	1	0.423	115	94	14	54
*	110	25	<b>761 069 532</b>	1	0.435	117	94	16	58
*	110	32	<b>761 069 533</b>	1	0.453	121	94	18	60
*	110	40	<b>761 069 534</b>	1	0.500	127	94	22	69
*	110	50	<b>761 069 535</b>	1	0.565	183	94	29	78



### Special reducer - female thread

Special reducer transition to female thread  
Thread in DZR brass, UBA (Umwelt Bundesamt, Germany) conform  
EPDM sealing hot and cold water approved

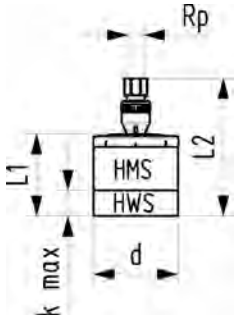

d (mm)	Rp (inch)	Code	SP	Weight (kg)	L1 (mm)	L2 (mm)	k max. (mm)
75	½	<b>761 069 749</b>	1	0.291	88	148	26
75	¾	<b>761 069 750</b>	1	0.339	88	149	26
75	1	<b>761 069 751</b>	1	0.414	88	154	26
90	½	<b>761 069 752</b>	1	0.344	87	147	27
90	¾	<b>761 069 753</b>	1	0.392	87	148	27
90	1	<b>761 069 754</b>	1	0.467	87	153	27
110	½	<b>761 069 755</b>	1	0.486	94	154	28
110	¾	<b>761 069 756</b>	1	0.534	94	155	28
110	1	<b>761 069 757</b>	1	0.609	94	160	28



### Special reducer - male thread

Special reducer transition to male thread  
Thread in DZR brass, UBA (Umwelt Bundesamt, Germany) conform  
EPDM sealing hot and cold water approved

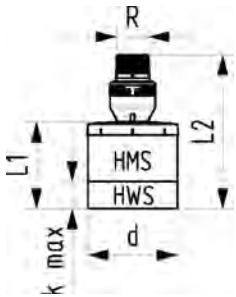

d (mm)	R (inch)	Code	SP	Weight (kg)	L1 (mm)	L2 (mm)	k max. (mm)
75	½	<b>761 069 740</b>	1	0.285	26	147	26
75	¾	<b>761 069 741</b>	1	0.316	26	150	26
75	1	<b>761 069 742</b>	1	0.393	26	156	26
90	½	<b>761 069 743</b>	1	0.338	27	146	27
90	¾	<b>761 069 744</b>	1	0.369	27	149	27
90	1	<b>761 069 745</b>	1	0.446	27	155	27
110	½	<b>761 069 746</b>	1	0.480	28	153	28
110	¾	<b>761 069 747</b>	1	0.511	28	156	28
110	1	<b>761 069 748</b>	1	0.588	28	156	28



### Special reducer

Not predrilled  
Not suitable as end cap

d1 (mm)	d2 (mm)	Code	SP	Weight (kg)	l (mm)
75	16 - 50	<b>761 069 454</b>	1	0.187	88
90	16 - 50	<b>761 069 455</b>	1	0.240	87
110	16 - 50	<b>761 069 456</b>	1	0.382	94

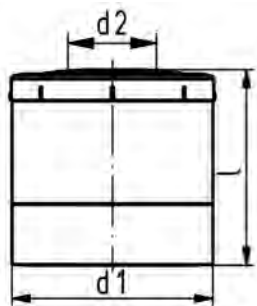

### Special reducer - predrilled

Drilled hole d16 to d50  
\* on request



	d1 (mm)	d2 (mm)	Code	SP	Weight (kg)	l (mm)
*	75	16	<b>761 069 500</b>	1	0.193	88
*	75	20	<b>761 069 501</b>	1	0.214	88
*	75	25	<b>761 069 502</b>	1	0.200	88
*	75	32	<b>761 069 503</b>	1	0.182	88
*	75	40	<b>761 069 504</b>	1	0.175	88
*	75	50	<b>761 069 505</b>	1	0.161	88
*	90	16	<b>761 069 506</b>	1	0.254	87
*	90	20	<b>761 069 507</b>	1	0.242	87
*	90	25	<b>761 069 508</b>	1	0.240	87
*	90	32	<b>761 069 509</b>	1	0.236	87
*	90	40	<b>761 069 510</b>	1	0.226	87
*	90	50	<b>761 069 511</b>	1	0.213	87
*	110	16	<b>761 069 512</b>	1	0.400	94
*	110	20	<b>761 069 513</b>	1	0.387	94
*	110	25	<b>761 069 514</b>	1	0.373	94
*	110	32	<b>761 069 515</b>	1	0.376	94
*	110	40	<b>761 069 516</b>	1	0.372	94
*	110	50	<b>761 069 517</b>	1	0.357	94

## Accessories

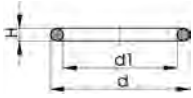

### EPDM O-Ring

Quality suitable for potable water

d (mm)	Code	SP Weight (kg)	d1 (mm)	D (mm)	H (mm)
16	761 066 558	1 0.002	19	26	4
20	761 066 124	1 0.002	23	31	4
25	761 066 125	1 0.001	28	35	4
32	761 066 126	1 0.001	36	43	4
40	761 066 127	1 0.004	44	55	5
50	761 066 128	1 0.001	53	64	5
63	761 066 129	1 0.002	69	80	5
75	761 070 036	1 0.007	82	93	5
90	761 070 037	1 0.008	101	112	5
110	761 070 038	1 0.016	120	134	7

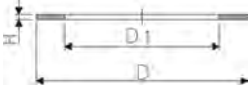

### Flat gasket

#### Model:

- Hardness approx. 65° Shore
- For adaptor unions

Size (inch)	D (mm)	D1 (mm)	H (mm)	EPDM Code	SP Weight (kg)	FPM Code	SP Weight (kg)
¼	20	13	2	748 400 004	1 0.002		
¾	24	17	2	748 400 005	1 0.002	749 400 005	1 0.020
½	30	21	3	748 400 006	1 0.002	749 400 006	1 0.003
¾	38	27	3	748 400 007	1 0.004	749 400 007	1 0.004
1	44	32	3	748 400 008	1 0.002	749 400 008	1 0.002
1 ¼	55	42	3	748 400 009	1 0.007	749 400 009	1 0.003
1 ½	62	46	3	748 400 010	1 0.004	749 400 010	1 0.007
2	78	60	3	748 400 011	1 0.005	749 400 011	1 0.006
2 ½	97	75	3	748 400 012	1 0.010	749 400 012	1 0.009
3	109	88	3	748 400 013	1 0.011	749 400 013	1 0.011



### Back-up ring

d (mm)	di (mm)	L (mm)	SDR	Code	SP Weight (kg)
125	102.2			761 065 283	1 0.300
		225	11	709 026 106	1 1.520

# Flanges

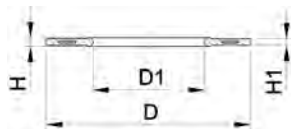

## Profile flange gasket metric For flange adaptors without chamfer

### Model:

- For flange adaptor No. 27 79 85 PP-H SDR11 without chamfer
- Profile Gasket with carbon steel insert (type G-ST-P/K)
- Hardness: 70° shore **EPDM**, 75° shore **FPM**

d (mm)	DN (mm)	PN (bar)	EPDM Code	SP	Weight (kg)	FPM Code	SP	Weight (kg)	D (mm)	D1 (mm)	H (mm)	H1 (mm)
20	15	16	<b>748 440 706</b>	1	0.009	<b>749 440 706</b>	1	0.013	51	20	4	3
25	20	16	<b>748 440 707</b>	1	0.015	<b>749 440 707</b>	1	0.014	61	22	4	3
32	25	16	<b>748 440 708</b>	1	0.013	<b>749 440 708</b>	1	0.019	71	28	4	3
40	32	16	<b>748 440 709</b>	1	0.019	<b>749 440 709</b>	1	0.026	82	40	4	3
50	40	16	<b>748 440 710</b>	1	0.029	<b>749 440 710</b>	1	0.039	92	46	4	3
63	50	16	<b>748 440 711</b>	1	0.041	<b>749 440 711</b>	1	0.050	107	58	5	4
75	65	16	<b>748 440 712</b>	1	0.053	<b>749 440 712</b>	1	0.082	127	69	5	4
90	80	16	<b>748 440 713</b>	1	0.064	<b>749 440 713</b>	1	0.083	142	84	5	4

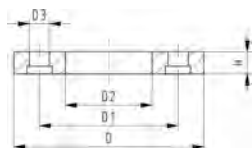

## Backing flanges PN 16 IPP

Material: Casting, GFK coated  
Suitable for flange adaptor  
Tighten the screws with torque as indicated  
Commercially available screws, nuts, washers  
\* on request

d (mm)	Code	SP	Weight (kg)
* 20	<b>761 065 270</b>	2	0.378
* 25	<b>761 065 271</b>	2	0.463
32	<b>761 065 272</b>	2	0.412
40	<b>761 065 273</b>	2	0.551
50	<b>761 065 274</b>	2	0.747
63	<b>761 065 275</b>	2	0.842
75	<b>761 065 276</b>	2	1.131
90	<b>761 065 277</b>	2	1.092
110	<b>761 065 278</b>	2	1.465

d (mm)	D (mm)	D1 (mm)	D2 (mm)	D3 (mm)	H (mm)	Tightening torque (mm)	○	SC
* 20	106	65	28	14	18	10	4	M 12x 70
* 25	118	75	34	14	18	15	4	M 12x 75
32	122	85	42	14	17	15	4	M 12x 75
40	142	100	51	18	17	20	4	M 16x 80
50	156	110	62	18	19	25	4	M 16x 85
63	171	125	78	18	20	35	4	M 16x 85
75	191	145	92	18	21	40	4	M 16x 90
90	206	160	110	18	21	40	8	M 16x 90
110	226	180	133	18	22	50	8	M 16x 95



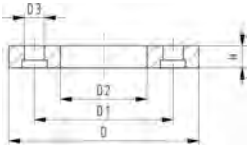

### Backing flanges

d (mm)	Code	SP	Weight (kg)
125	<b>761 065 279</b>	2	1.284
160	<b>761 065 280</b>	2	2.406
225	<b>761 065 281</b>	2	3.600

d (mm)	D (mm)	D1 (mm)	D2 (mm)	D3 (mm)	H (mm)	AL	Screws	Tightening torque (mm)
125	226	180	135	18	23	8	M16 x 130	50
160	296	240	178	22	28	8	M20 x 140	60
225	350	295	238	22	31	8	M20 x 160	75



# INSTAFLEX

## Socket fusion jointing HMS





Fittings

106



Special reducers

110

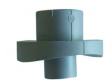

Weld-in saddles

113



Flange connections

115

# Socket fusion d16-d110

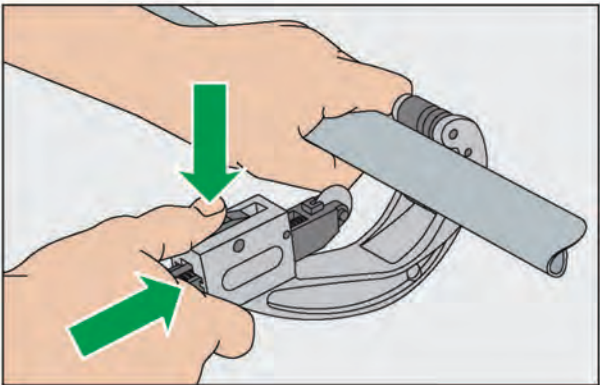

1

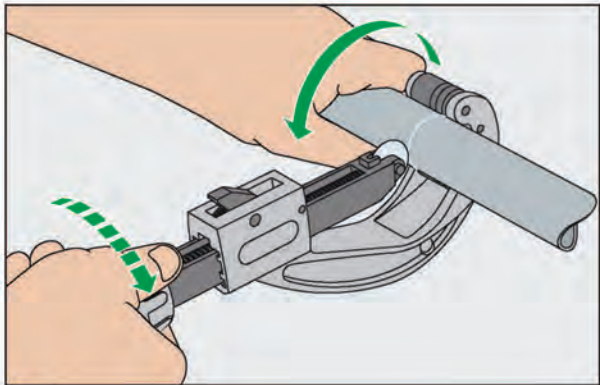

2

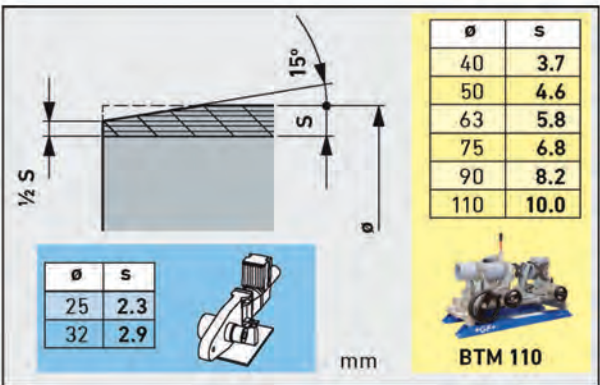

3



4

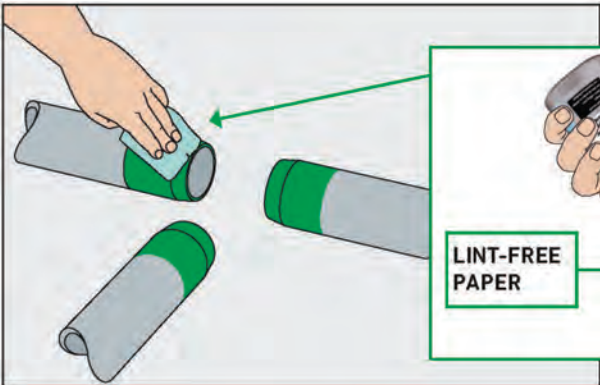

5

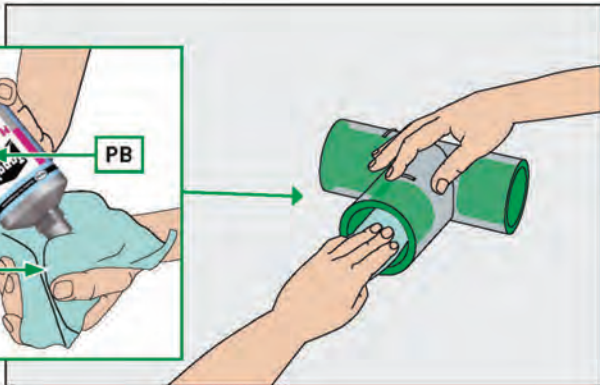

6

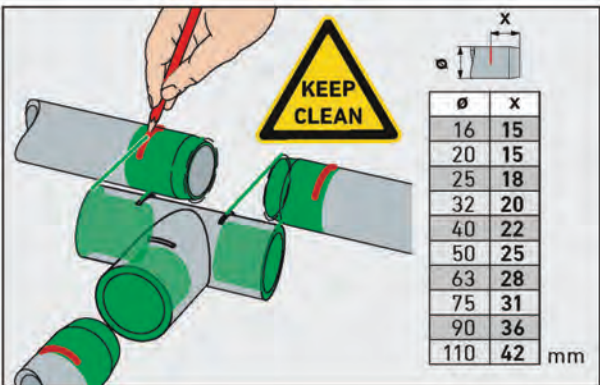

7

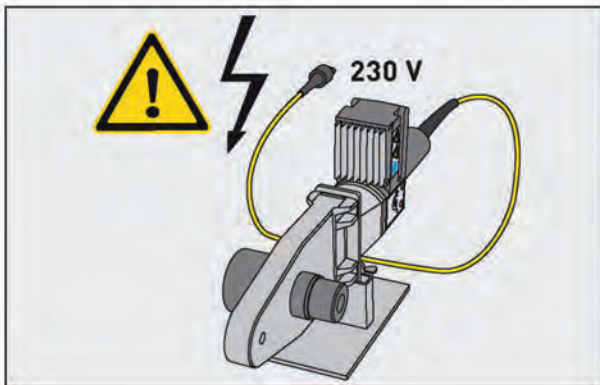

8



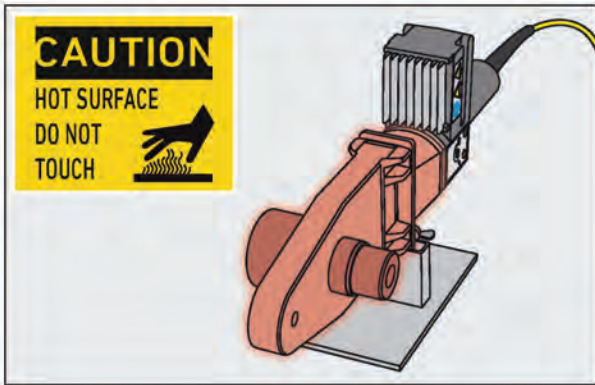

9

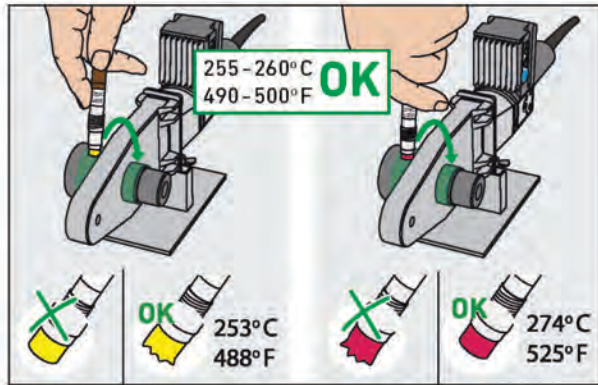

10

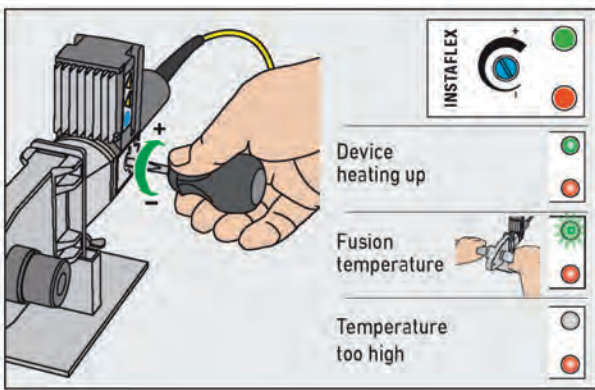

11

Pipe	mm	16	20	25	32	40	50	63	75	90	100
Heating time	s	5	6	6	10	14	18	22	26	30	35
Holding time	s	15	15	15	20	20	30	30	60	75	90
Cooling time	min	2	2	2	4	4	4	6	6	6	6

BTM 110

12

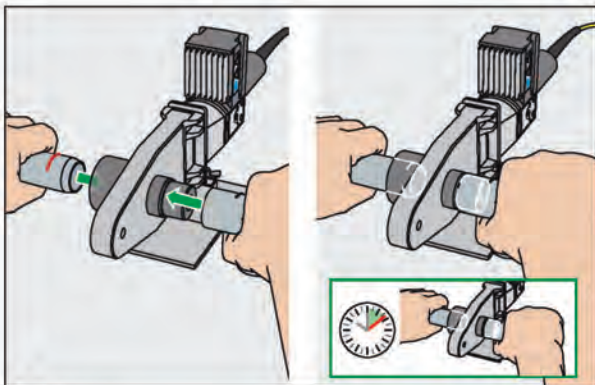

13

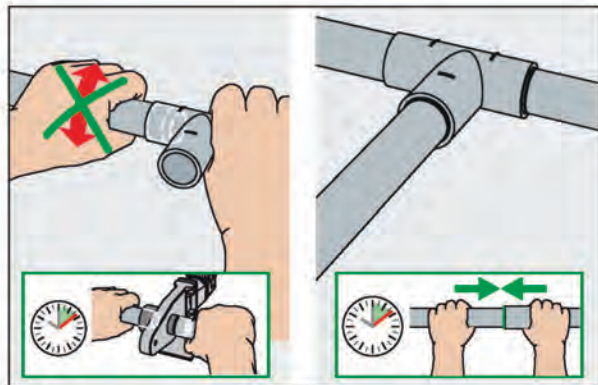

14

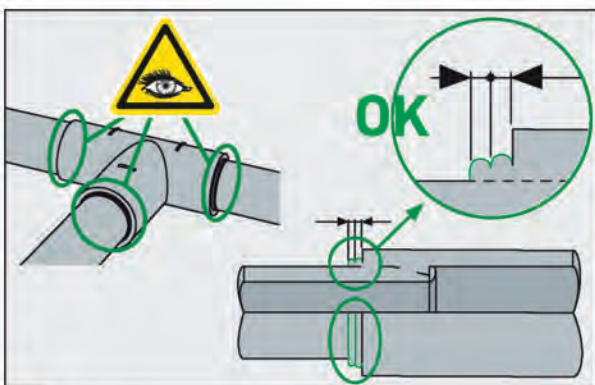

15

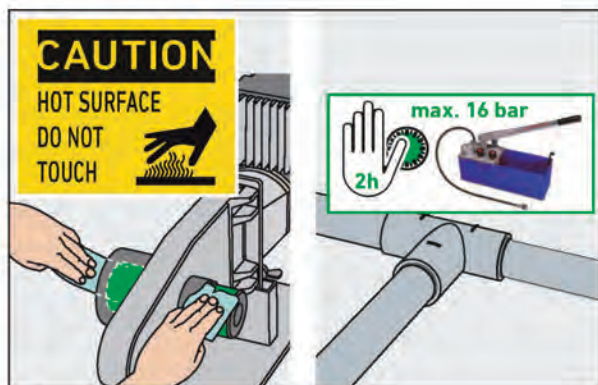

16

# Fittings

## Elbow 90°



d (mm)	Code	SP	Weight (kg)	D (mm)	L (mm)	z (mm)
16	<b>761 066 600</b>	10	0.014	22	25	10
20	<b>761 066 601</b>	10	0.015	26	28	13
25	<b>761 066 602</b>	10	0.020	32	32	14
32	<b>761 066 603</b>	10	0.035	40	38	18
40	<b>761 066 604</b>	5	0.080	51	44	22
50	<b>761 066 605</b>	5	0.116	64	51	26
63	<b>761 066 606</b>	2	0.217	81	62	34
75	<b>761 066 607</b>	2	0.303	91	75	44
90	<b>761 066 608</b>	2	0.466	108	88	52
110	<b>761 066 609</b>	2	0.856	132	105	63

## Elbow 90° - socket spigot

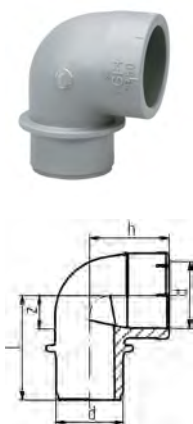

d (mm)	Code	SP	Weight (kg)	D (mm)	L (mm)	h (mm)	z (mm)
16	<b>761 066 900</b>	10	0.009	22	34	25	10
20	<b>761 066 901</b>	10	0.012	26	36	28	13
25	<b>761 066 902</b>	10	0.021	32	44	32	14
32	<b>761 066 903</b>	10	0.037	40	50	38	18
40	<b>761 066 904</b>	5	0.067	51	58	44	22
50	<b>761 066 905</b>	5	0.122	64	70	51	26
63	<b>761 066 906</b>	2	0.233	81	82	62	34

## Elbow 45°



d (mm)	Code	SP	Weight (kg)	D (mm)	L (mm)	z (mm)
16	<b>761 066 610</b>	10	0.008	22	21	6
20	<b>761 066 611</b>	10	0.016	26	22	7
25	<b>761 066 612</b>	10	0.026	32	25	7
32	<b>761 066 613</b>	10	0.030	40	30	10
40	<b>761 066 614</b>	5	0.064	51	34	12
50	<b>761 066 615</b>	5	0.093	64	39	14
63	<b>761 066 616</b>	2	0.145	81	45	17
75	<b>761 066 617</b>	2	0.223	92	51	20
90	<b>761 066 618</b>	2	0.337	109	58	22
110	<b>761 066 619</b>	2	0.616	134	68	26



### Elbow 45° - socket spigot

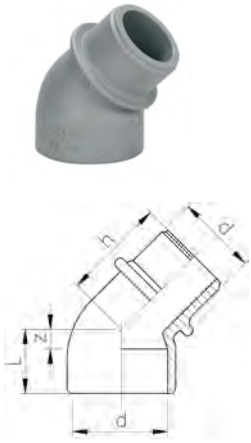

d (mm)	Code	SP	Weight (kg)	D (mm)	L (mm)	h (mm)	z (mm)
16	<b>761 066 907</b>	10	0.008	22	21	29	6
20	<b>761 066 908</b>	10	0.011	26	22	30	7
25	<b>761 066 909</b>	10	0.017	32	25	35	7
32	<b>761 066 910</b>	10	0.032	40	30	40	10
40	<b>761 066 911</b>	5	0.055	51	34	46	12
50	<b>761 066 912</b>	5	0.101	64	39	53	14
63	<b>761 066 913</b>	2	0.258	81	45	62	17

### T-piece 90° - equal



d (mm)	Code	SP	Weight (kg)	D (mm)	L (mm)	z (mm)
16	<b>761 066 620</b>	10	0.017	22	25	10
20	<b>761 066 621</b>	10	0.025	26	28	13
25	<b>761 066 622</b>	10	0.036	32	32	14
32	<b>761 066 623</b>	10	0.045	40	38	18
40	<b>761 066 624</b>	5	0.105	51	44	22
50	<b>761 066 625</b>	5	0.147	64	51	26
63	<b>761 066 626</b>	2	0.315	81	62	34
75	<b>761 066 627</b>	2	0.375	91	75	44
90	<b>761 066 628</b>	2	0.694	112	88	52
110	<b>761 066 629</b>	2	1.120	132	105	63

### T-piece 90° - reduced

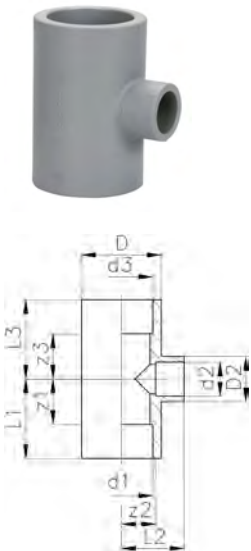

d1 (mm)	d2 (mm)	d3 (mm)	Code	SP	Weight (kg)	D (mm)	D2 (mm)	L1 (mm)	L2 (mm)	L3 (mm)	z1 (mm)	z2 (mm)	z3 (mm)
20	16	20	<b>761 066 914</b>	10	0.015	26	22	28	28	28	13	13	13
20	16	16	<b>761 066 915</b>	10	0.016	26	22	28	28	28	13	13	13
20	20	16	<b>761 066 916</b>	10	0.017	26	26	28	28	28	13	13	13
25	16	25	<b>761 066 917</b>	10	0.025	32	26	32	32	32	14	17	14
25	20	25	<b>761 066 918</b>	10	0.025	32	26	32	32	32	14	17	14
25	20	20	<b>761 066 919</b>	10	0.026	32	26	32	32	32	14	17	17
25	25	20	<b>761 066 920</b>	10	0.027	32	32	32	32	32	14	14	17
32	16	32	<b>761 066 921</b>	10	0.041	40	26	38	38	38	18	23	18
32	20	32	<b>761 066 922</b>	5	0.040	40	26	38	38	38	18	23	18
32	25	32	<b>761 066 923</b>	10	0.036	40	32	38	38	38	18	20	18
40	16	40	<b>761 066 295</b>	5	0.083	51	34	44	44	44	22	29	22
40	25	40	<b>761 066 924</b>	5	0.077	51	34	44	44	44	22	26	22
40	32	40	<b>761 068 049</b>	5	0.076	51	40	44	44	44	22	24	22
50	16	50	<b>761 066 309</b>	5	0.135	64	34	51	51	51	26	36	26
50	25	50	<b>761 066 925</b>	5	0.131	64	34	51	51	51	26	33	26
50	32	50	<b>761 068 050</b>	5	0.133	64	40	51	51	51	26	31	26
63	16	63	<b>761 066 310</b>	2	0.257	81	35	62	62	62	34	47	34
63	25	63	<b>761 066 926</b>	5	0.252	81	35	62	62	62	34	44	34
63	32	63	<b>761 068 051</b>	5	0.255	81	40	62	62	62	34	42	34

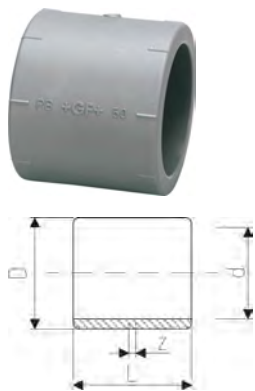

### Socket

d (mm)	Code	SP	Weight (kg)	D (mm)	L (mm)	z (mm)
16	<b>761 066 660</b>	10	0.009	22	33	3
20	<b>761 066 661</b>	10	0.014	26	33	3
25	<b>761 066 662</b>	10	0.020	32	39	3
32	<b>761 066 663</b>	10	0.033	40	43	3
40	<b>761 066 664</b>	10	0.048	51	48	4
50	<b>761 066 665</b>	10	0.069	64	54	4
63	<b>761 066 666</b>	2	0.120	81	60	4
75	<b>761 066 667</b>	2	0.153	91	69	7
90	<b>761 066 668</b>	2	0.236	110	80	8
110	<b>761 066 669</b>	2	0.417	133	94	10

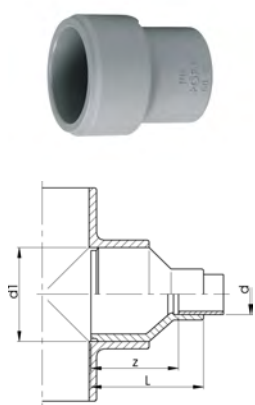

### Reducing bush

d (mm)	d1 (mm)	Code	SP	Weight (kg)	L (mm)	z (mm)
16	20	<b>761 066 670</b>	10	0.005	30	15
16	25	<b>761 066 671</b>	10	0.010	33	18
20	25	<b>761 066 672</b>	10	0.015	33	18
20	32	<b>761 066 674</b>	10	0.018	40	25
25	32	<b>761 066 675</b>	10	0.022	40	22
20	40	<b>761 066 677</b>	10	0.024	42	27
25	40	<b>761 066 678</b>	10	0.028	42	24
32	40	<b>761 066 679</b>	10	0.034	42	22
20	50	<b>761 066 681</b>	10	0.035	55	40
25	50	<b>761 066 682</b>	10	0.035	55	37
32	50	<b>761 066 683</b>	10	0.042	55	35
40	50	<b>761 066 684</b>	10	0.050	55	33
20	63	<b>761 066 686</b>	5	0.055	58	43
25	63	<b>761 066 687</b>	5	0.060	58	40
32	63	<b>761 066 688</b>	5	0.066	58	38
40	63	<b>761 066 689</b>	5	0.074	58	36
50	63	<b>761 066 690</b>	5	0.079	58	33
63	75	<b>761 066 742</b>	2	0.115	67	39
63	90	<b>761 066 746</b>	2	0.150	74	46
75	90	<b>761 066 745</b>	2	0.160	74	43
63	110	<b>761 066 747</b>	2	0.229	86	58
75	110	<b>761 066 749</b>	2	0.234	86	55
90	110	<b>761 066 748</b>	2	0.270	86	50



### End cap

d (mm)	Code	SP	Weight (kg)	L (mm)
16	<b>761 066 650</b>	10	0.006	22
20	<b>761 066 651</b>	10	0.010	24
25	<b>761 066 652</b>	10	0.014	28
32	<b>761 066 653</b>	10	0.022	32
40	<b>761 066 654</b>	10	0.024	38
50	<b>761 066 655</b>	10	0.050	44
63	<b>761 066 656</b>	5	0.079	50



### Plug

d (mm)	Code	SP	Weight (kg)	h (mm)
25	<b>761 066 938</b>	10	0.008	33

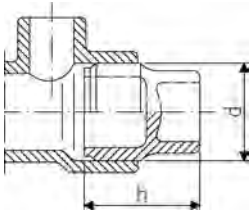

### Connection box

The connection box can be used for embedded sprinkler applications

Rp (inch)	Code	SP	Weight (kg)	d (mm)	l1 (mm)	l2 (mm)	l3 (mm)
½	<b>761 068 053</b>	10	0.460	63	131	82	40
1	<b>761 068 052</b>	10	0.366	63	131	82	40

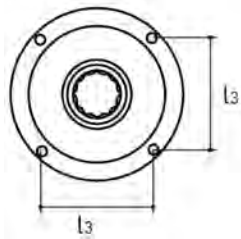
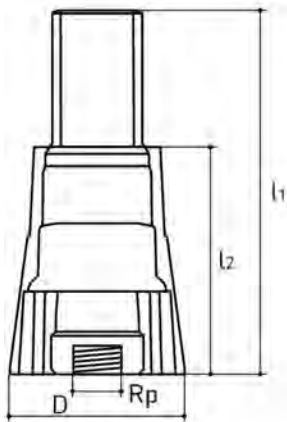

# Special reducers

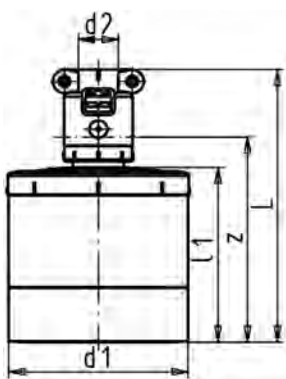

## Special reducer with adaptor

\* on request

	d1 (mm)	d2 (mm)	Code	SP	Weight (kg)	l (mm)	l1 (mm)	z (mm)
*	75	16	<b>761 069 604</b>	1	0.212	134	88	97
*	75	20	<b>761 069 605</b>	1	0.216	134	88	95
*	75	25	<b>761 069 606</b>	1	0.221	137	88	95
*	75	32	<b>761 069 607</b>	1	0.237	139	88	97
*	75	40	<b>761 069 608</b>	1	0.254	145	88	98
*	75	50	<b>761 069 609</b>	1	0.270	148	88	99
*	90	16	<b>761 069 610</b>	1	0.254	133	87	96
*	90	20	<b>761 069 611</b>	1	0.265	133	87	94
*	90	25	<b>761 069 612</b>	1	0.267	136	87	94
*	90	32	<b>761 069 613</b>	1	0.277	138	87	96
*	90	40	<b>761 069 614</b>	1	0.297	144	87	97
*	90	50	<b>761 069 615</b>	1	0.322	147	87	98
*	110	16	<b>761 069 518</b>	1	0.405	140	94	103
*	110	20	<b>761 069 519</b>	1	0.405	140	94	101
*	110	25	<b>761 069 520</b>	1	0.414	143	94	101
*	110	32	<b>761 069 521</b>	1	0.433	145	94	103
*	110	40	<b>761 069 522</b>	1	0.461	151	94	104
*	110	50	<b>761 069 523</b>	1	0.469	154	94	105

## Special reducer with transition on elbow

\* additional diameter on request

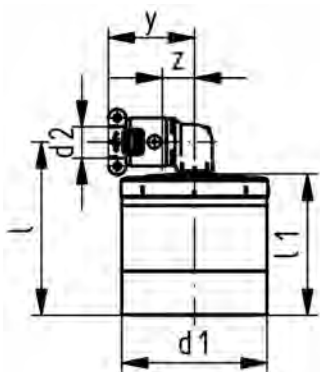

	d1 (mm)	d2 (mm)	Code	SP	Weight (kg)	l (mm)	l1 (mm)	z (mm)	y (mm)
*	75	20	<b>761 069 619</b>	1	0.228	109	88	14	54
*	75	25	<b>761 069 524</b>	1	0.235	111	88	16	58
*	75	32	<b>761 069 525</b>	1	0.249	115	88	18	60
*	75	40	<b>761 069 526</b>	1	0.300	121	88	22	96
*	75	50	<b>761 069 527</b>	1	0.326	127	88	29	78
*	90	20	<b>761 069 620</b>	1	0.273	108	87	14	54
*	90	25	<b>761 069 528</b>	1	0.283	110	87	16	58
*	90	32	<b>761 069 529</b>	1	0.300	114	87	18	60
*	90	40	<b>761 069 530</b>	1	0.350	120	87	22	69
*	90	50	<b>761 069 531</b>	1	0.415	126	87	29	78
*	110	20	<b>761 069 621</b>	1	0.423	115	94	14	54
*	110	25	<b>761 069 532</b>	1	0.435	117	94	16	58
*	110	32	<b>761 069 533</b>	1	0.453	121	94	18	60
*	110	40	<b>761 069 534</b>	1	0.500	127	94	22	69
*	110	50	<b>761 069 535</b>	1	0.565	183	94	29	78



### Special reducer - female thread

Special reducer transition to female thread  
Thread in DZR brass, UBA (Umwelt Bundesamt, Germany) conform  
EPDM sealing hot and cold water approved

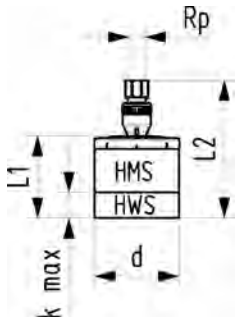

d (mm)	Rp (inch)	Code	SP	Weight (kg)	L1 (mm)	L2 (mm)	k max. (mm)
75	½	<b>761 069 749</b>	1	0.291	88	148	26
75	¾	<b>761 069 750</b>	1	0.339	88	149	26
75	1	<b>761 069 751</b>	1	0.414	88	154	26
90	½	<b>761 069 752</b>	1	0.344	87	147	27
90	¾	<b>761 069 753</b>	1	0.392	87	148	27
90	1	<b>761 069 754</b>	1	0.467	87	153	27
110	½	<b>761 069 755</b>	1	0.486	94	154	28
110	¾	<b>761 069 756</b>	1	0.534	94	155	28
110	1	<b>761 069 757</b>	1	0.609	94	160	28



### Special reducer - male thread

Special reducer transition to male thread  
Thread in DZR brass, UBA (Umwelt Bundesamt, Germany) conform  
EPDM sealing hot and cold water approved

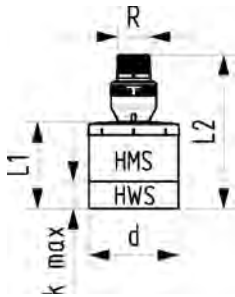

d (mm)	R (inch)	Code	SP	Weight (kg)	L1 (mm)	L2 (mm)	k max. (mm)
75	½	<b>761 069 740</b>	1	0.285	26	147	26
75	¾	<b>761 069 741</b>	1	0.316	26	150	26
75	1	<b>761 069 742</b>	1	0.393	26	156	26
90	½	<b>761 069 743</b>	1	0.338	27	146	27
90	¾	<b>761 069 744</b>	1	0.369	27	149	27
90	1	<b>761 069 745</b>	1	0.446	27	155	27
110	½	<b>761 069 746</b>	1	0.480	28	153	28
110	¾	<b>761 069 747</b>	1	0.511	28	156	28
110	1	<b>761 069 748</b>	1	0.588	28	156	28



### Special reducer

Not predrilled  
Not suitable as end cap

d1 (mm)	d2 (mm)	Code	SP	Weight (kg)	l (mm)
75	16 - 50	<b>761 069 454</b>	1	0.187	88
90	16 - 50	<b>761 069 455</b>	1	0.240	87
110	16 - 50	<b>761 069 456</b>	1	0.382	94

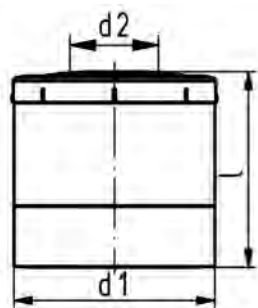

### Special reducer - predrilled

Drilled hole d16 to d50  
\* on request

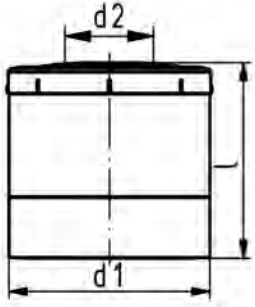

	<b>d1</b> (mm)	<b>d2</b> (mm)	<b>Code</b>	<b>SP</b>	<b>Weight</b> (kg)	<b>l</b> (mm)
*	75	16	<b>761 069 500</b>	1	0.193	88
*	75	20	<b>761 069 501</b>	1	0.214	88
*	75	25	<b>761 069 502</b>	1	0.200	88
*	75	32	<b>761 069 503</b>	1	0.182	88
*	75	40	<b>761 069 504</b>	1	0.175	88
*	75	50	<b>761 069 505</b>	1	0.161	88
*	90	16	<b>761 069 506</b>	1	0.254	87
*	90	20	<b>761 069 507</b>	1	0.242	87
*	90	25	<b>761 069 508</b>	1	0.240	87
*	90	32	<b>761 069 509</b>	1	0.236	87
*	90	40	<b>761 069 510</b>	1	0.226	87
*	90	50	<b>761 069 511</b>	1	0.213	87
*	110	16	<b>761 069 512</b>	1	0.400	94
*	110	20	<b>761 069 513</b>	1	0.387	94
*	110	25	<b>761 069 514</b>	1	0.373	94
*	110	32	<b>761 069 515</b>	1	0.376	94
*	110	40	<b>761 069 516</b>	1	0.372	94
*	110	50	<b>761 069 517</b>	1	0.357	94

# Weld-in saddles

## Weld-in saddle

\* on request

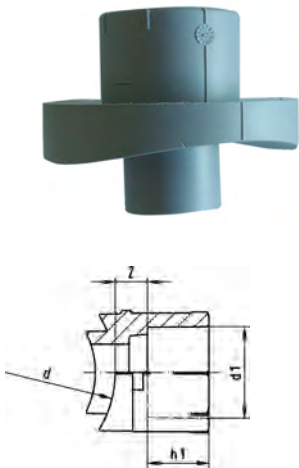

	<b>d - d1</b> (mm)	<b>Code</b>	<b>SP</b>	<b>Weight</b> (kg)	<b>h1</b> (mm)	<b>z</b> (mm)
*	40 - 20	<b>761 068 000</b>	5	0.011	15	11
	50 - 20	<b>761 068 003</b>	5	0.011	15	11
	50 - 25	<b>761 068 004</b>	5	0.014	18	11
	50 - 32	<b>761 068 005</b>	5	0.019	20	11
	63 - 20	<b>761 068 006</b>	5	0.012	15	11
	63 - 25	<b>761 068 007</b>	5	0.016	18	11
	63 - 32	<b>761 068 008</b>	5	0.022	20	11
	75 - 20	<b>761 068 009</b>	5	0.014	15	12
	75 - 25	<b>761 068 010</b>	5	0.017	18	12
	75 - 32	<b>761 068 011</b>	5	0.022	20	12
	90 - 20	<b>761 068 012</b>	5	0.018	15	13
	90 - 25	<b>761 068 013</b>	5	0.021	18	13
	90 - 32	<b>761 068 014</b>	5	0.027	20	13
	110 - 20	<b>761 068 015</b>	5	0.019	15	14
	110 - 25	<b>761 068 016</b>	5	0.022	18	14
	110 - 32	<b>761 068 017</b>	5	0.020	20	14

## Weld-in saddle

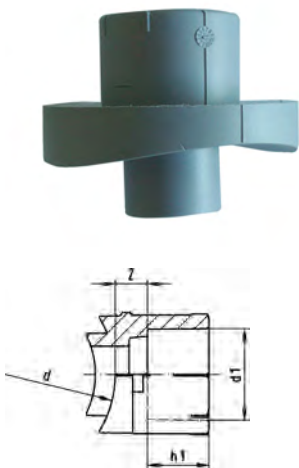

	<b>d - d1</b> (mm)	<b>Code</b>	<b>SP</b>	<b>Weight</b> (kg)	<b>h1</b> (mm)	<b>z</b> (mm)
	125 - 32	<b>761 068 018</b>	5	0.035	20	16
	125 - 40	<b>761 068 019</b>	5	0.056	22	16
	125 - 50	<b>761 068 020</b>	5	0.072	25	16
	160 - 32	<b>761 068 021</b>	5	0.045	20	16
	160 - 40	<b>761 068 022</b>	5	0.061	22	16
	160 - 50	<b>761 068 023</b>	5	0.077	25	16
	225 - 32	<b>761 068 024</b>	5	0.076	20	16
	225 - 40	<b>761 068 025</b>	5	0.076	22	16
	225 - 50	<b>761 068 026</b>	5	0.092	25	16



### Weld-in saddle - male thread

Weld-in saddle transition to male thread  
 Thread in DZR brass, UBA (Umwelt Bundesamt, Germany) conform  
 EPDM sealing hot and cold water approved

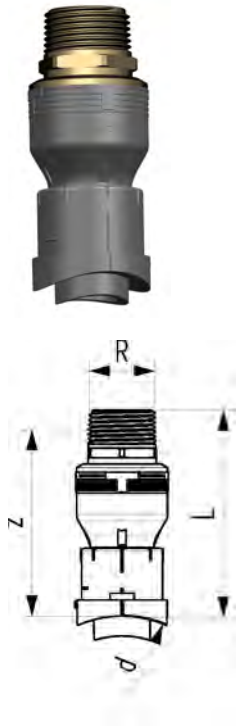

d (mm)	R (inch)	Code	SP	Weight (kg)	L (mm)	z (mm)
50	3/4	<b>761 069 758</b>	2	0.143	100	75
63	1	<b>761 069 759</b>	2	0.228	100	83
75	1	<b>761 069 760</b>	2	0.228	100	83
90	1	<b>761 069 761</b>	2	0.233	103	86
110	1	<b>761 069 762</b>	2	0.226	105	88
125	1	<b>761 069 763</b>	2	0.241	108	91
160	1	<b>761 069 764</b>	2	0.251	108	91
225	1	<b>761 069 765</b>	2	0.282	108	91

# Flange connections

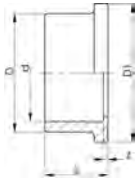

## PB flange adaptor

Transition to ball valve 564

d (mm)	Code	SP	Weight (kg)	D (mm)	D1 (mm)	L (mm)	z (mm)
20	<b>761 066 940</b>	2	0.005	27	33	20	3
25	<b>761 066 941</b>	2	0.012	33	44	22	3
32	<b>761 066 942</b>	2	0.016	41	53	24	3
40	<b>761 066 943</b>	2	0.026	51	65	26	3
50	<b>761 066 944</b>	2	0.041	62	77	29	3
63	<b>761 066 945</b>	2	0.075	77	99	34	3

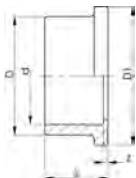

## Flange adaptor flat

Suitable for flange or union nut

d (mm)	Code	SP	Weight (kg)	D (mm)	D1 (mm)	L (mm)	z (mm)
16	<b>761 066 630</b>	10	0.005				
20	<b>761 066 631</b>	10	0.007	27	34	20	5
25	<b>761 066 632</b>	10	0.010	33	41	23	5
32	<b>761 066 633</b>	10	0.017	41	50	25	5
40	<b>761 066 634</b>	10	0.026	50	61	27	5
50	<b>761 066 635</b>	10	0.039	61	73	30	5
63	<b>761 066 636</b>	2	0.063	76	90	33	5
75	<b>761 066 637</b>	2	0.093	90	106	35	4
90	<b>761 066 638</b>	2	0.140	109	125	42	6
110	<b>761 066 639</b>	2	0.230	131	150	49	7

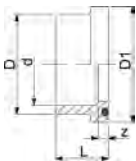

## Flange adaptor with groove

Suitable for flange or union nut

Including EPDM O-Ring, quality suitable for potable water

d (mm)	Code	SP	Weight (kg)	D (mm)	D1 (mm)	L (mm)	z (mm)
16	<b>761 066 640</b>	10	0.006	22	29	23	8
20	<b>761 066 641</b>	10	0.008	27	34	23	8
25	<b>761 066 642</b>	10	0.012	33	41	26	8
32	<b>761 066 643</b>	10	0.021	41	50	28	8
40	<b>761 066 644</b>	10	0.034	50	61	32	10
50	<b>761 066 645</b>	10	0.049	61	73	35	10
63	<b>761 066 646</b>	2	0.077	76	90	38	10
75	<b>761 066 647</b>	2	0.111	90	106	40	9
90	<b>761 066 648</b>	2	0.179	109	125	47	11
110	<b>761 066 649</b>	2	0.292	131	150	55	13

# INSTAFLEX

Butt fusion

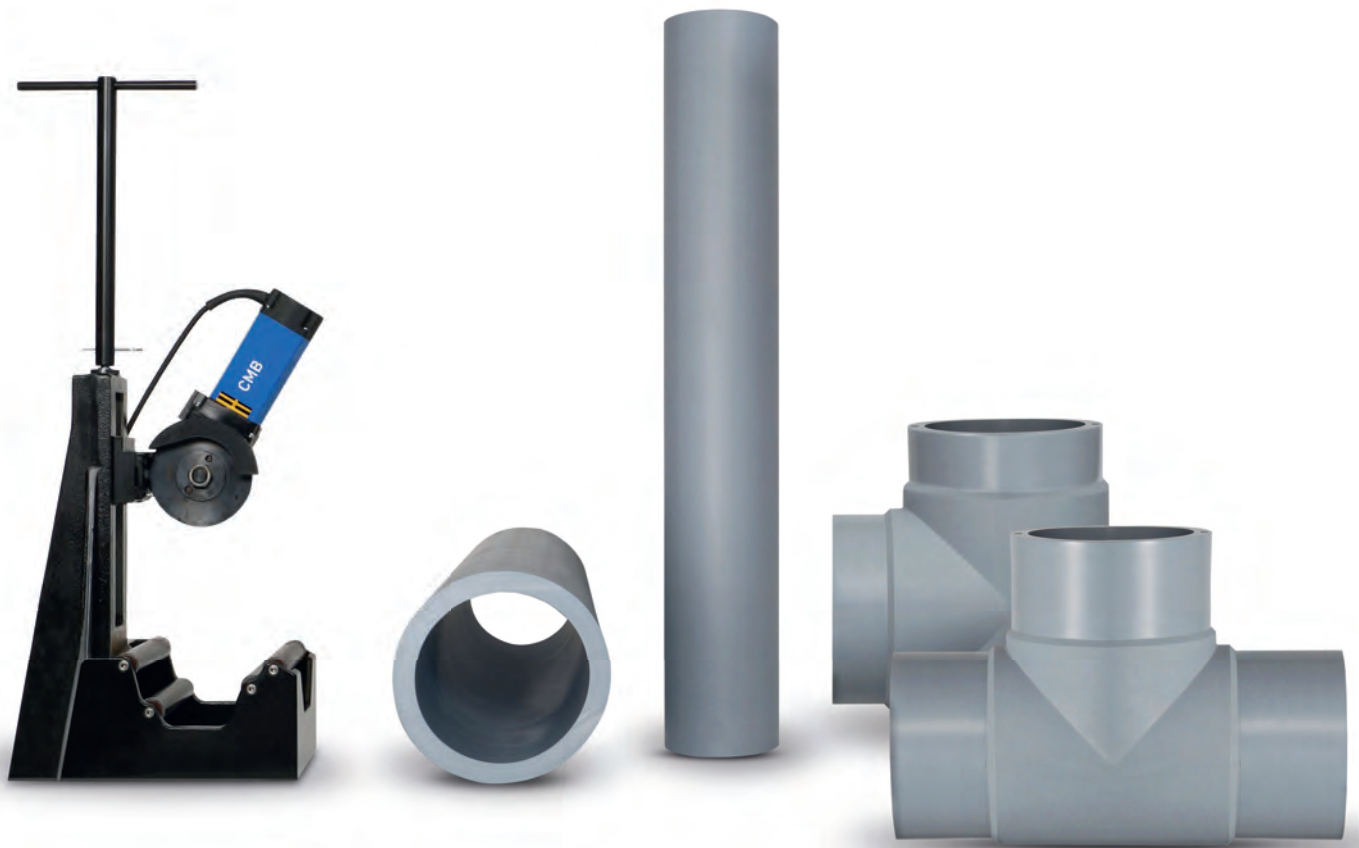



Butt fusion fittings

118



Flange connections

119

# Butt fusion fittings

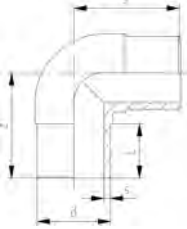

## Elbow 90°

d (mm)	Code	SP	Weight (kg)	L (mm)	z (mm)
125	<b>761 065 258</b>	1	1.615	93	182
160	<b>761 065 259</b>	1	3.077	104	213
225	<b>761 065 260</b>	1	7.588	122	270

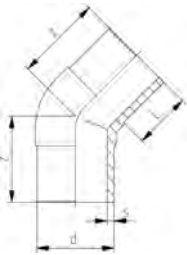

## Elbow 45°

d (mm)	Code	SP	Weight (kg)	L (mm)	z (mm)
125	<b>761 065 261</b>	1	1.246	92	140
160	<b>761 065 262</b>	1	2.379	102	162
225	<b>761 065 263</b>	1	6.065	122	200



## Tee 90° - equal

d (mm)	Code	SP	Weight (kg)	L (mm)	z (mm)
125	<b>761 065 255</b>	1	2.397	93	183
160	<b>761 065 256</b>	1	4.312	102	210
225	<b>761 065 257</b>	1	11.984	122	270

# Flange connections

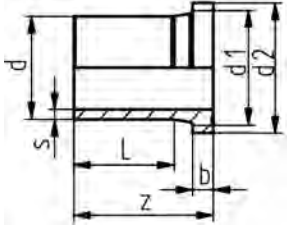
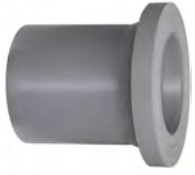

## Flange adaptor - flat

d (mm)	Code	SP	Weight (kg)	d1 (mm)	d2 (mm)	L (mm)	b (mm)	z (mm)
125	<b>761 065 264</b>	1	0.864	132	162	123	25	170
160	<b>761 065 265</b>	1	1.667	176	218	147	25	200
225	<b>761 065 266</b>	1	3.003	236	274	122	32	200



## Back-up ring

d (mm)	di (mm)	L (mm)	SDR	Code	SP	Weight (kg)
125	102.2			<b>761 065 283</b>	1	0.300
		225	11	<b>709 026 106</b>	1	1.520

# INSTAFLEX

## Compression Jointing







Compression joint fittings

122



Manifolds in nonferrous metal

126



Accessories for compression joint fittings

127

# Compression joint fittings

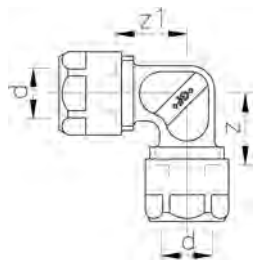

## Elbow 90°

d (mm)	Code	SP	Weight (kg)	z (mm)	z1 (mm)
16	<b>760 854 842</b>	5	0.206	22	22
20	<b>760 854 843</b>	5	0.280	24	24

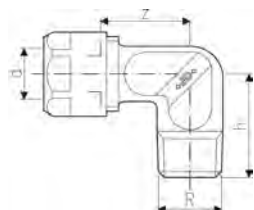

## Transition elbow 90° - male thread

d (mm)	R (inch)	Code	SP	Weight (kg)	h (mm)	z (mm)
16	½	<b>760 854 838</b>	5	0.171	35	27
16	¾	<b>760 854 839</b>	2	0.188	35	27
20	¾	<b>760 854 840</b>	5	0.208	35	29
25	¾	<b>760 854 819</b>	2	0.236	44	34
20	½	<b>760 869 991</b>	5	0.207	35	29

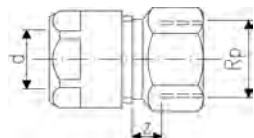

## Transition - female thread

d (mm)	Rp (inch)	Code	SP	Weight (kg)	z (mm)
16	½	<b>760 853 104</b>	5	0.078	12
16	¾	<b>760 853 105</b>	5	0.144	15
20	½	<b>760 853 194</b>	5	0.204	14
20	¾	<b>760 853 153</b>	5	0.174	15

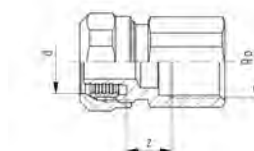

## Transition - female thread

\* on request

d (mm)	Rp (inch)	Code	SP	Weight (kg)	z (mm)	Remarks
25	¾	<b>760 856 231</b>	10	0.124	7	
25	1	<b>760 856 232</b>	10	0.202	13	
32	1	<b>760 856 233</b>	10	0.261	7	
40	1 ¼	<b>760 856 234</b>	10	0.364	7	
50	1 ½	<b>760 856 235</b>	5	0.506	7	
63	2	<b>760 856 236</b>	1	1.896	9	
75	2 ½	<b>760 856 248</b>	1	1.907	10	without approval
*	90	<b>760 856 261</b>	1	0.800	9	without approval
*	110	<b>760 856 262</b>	1	5.800	38	without approval



### Transition - male thread

d (mm)	R (inch)	Code	SP	Weight (kg)	h (mm)
16	½	<b>760 853 107</b>	5	0.111	30
16	¾	<b>760 853 108</b>	5	0.156	34
20	½	<b>760 853 195</b>	5	0.148	38
20	¾	<b>760 853 138</b>	5	0.230	36



### Transition - male thread

\* on request



d (mm)	R (inch)	Code	SP	Weight (kg)	h (mm)	Remarks
25	¾	<b>760 856 241</b>	10	0.144	35	
25	1	<b>760 856 242</b>	10	0.177	41	
32	1	<b>760 856 243</b>	10	0.293	42	
40	1 ¼	<b>760 856 244</b>	10	0.409	44	
50	1 ½	<b>760 856 245</b>	5	0.576	47	
63	2	<b>760 856 246</b>	1	1.736	32	
75	2 ½	<b>760 856 247</b>	1	2.093	37	without approval
*	90	<b>760 856 263</b>	1	2.806	32	without approval
*	110	<b>760 856 264</b>	1	3.429	38	without approval



### Transition - soldering end, socket

d (mm)	dCu (mm)	Code	SP	Weight (kg)	z (mm)
16	15	<b>760 853 114</b>	2	0.010	14
16	18	<b>760 853 196</b>	2	0.093	12
20	18	<b>760 853 197</b>	2	0.188	14
20	22	<b>760 853 139</b>	2	0.158	11



### Transition - soldering end, spigot

d (mm)	dCu (mm)	Code	SP	Weight (kg)	h (mm)
16	15	<b>760 853 113</b>	2	0.100	28
16	18	<b>760 853 198</b>	2	0.104	30
20	18	<b>760 853 199</b>	2	0.142	35
20	22	<b>760 854 700</b>	2	0.190	38

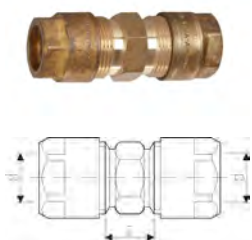

### Socket

d (mm)	Code	SP	Weight (kg)	z (mm)
16	<b>760 853 124</b>	2	0.156	26
20	<b>760 853 151</b>	2	0.300	28



### T-piece 90° - equal

d (mm)	Code	SP	Weight (kg)	z (mm)
16	<b>760 853 125</b>	2	0.275	22
20	<b>760 853 131</b>	2	0.416	24

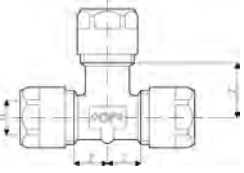

### T-piece 90° - reduced

d1 (mm)	d2 (mm)	d3 (mm)	Code	SP	Weight (kg)	z1 (mm)	z2 (mm)	z3 (mm)
20	16	20	<b>760 853 136</b>	2	0.380	24	23	23
20	16	16	<b>760 853 140</b>	2	0.342	24	23	23
20	20	16	<b>760 853 137</b>	2	0.375	24	24	23

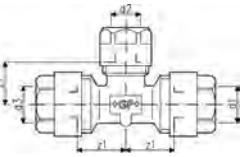

### Transition T-piece - female thread

d (mm)	Rp (inch)	Code	SP	Weight (kg)	z1 (mm)	z2 (mm)	z3 (mm)
20	½	<b>760 854 841</b>	5	0.340	24	22	24

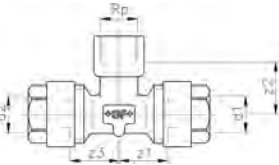

### Transition T-piece - male thread

d (mm)	R (inch)	Code	SP	Weight (kg)	h (mm)	z (mm)
16	½	<b>760 854 711</b>	2	0.225	38	19
20	½	<b>760 856 211</b>	2	0.327	39	24

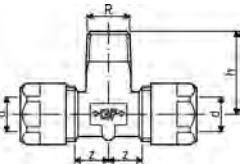



### Transition T-piece - male thread

d (mm)	R (inch)	Code	SP	Weight (kg)	h (mm)	z (mm)
16	1/2	<b>760 869 987</b>	2	0.209	30	22

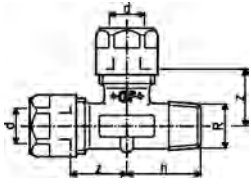

### Transition union flat seal - male thread

Including gasket, tesnit blue free of asbestos, according to DIN 3754

G (inch)	R (inch)	Code	SP	Weight (kg)	h (mm)
3/4	3/4	<b>760 854 716</b>	2	0.109	37

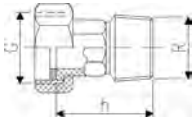

### Transition pipe

Substitute: GF JRG Sanipex n° 5451.100

\* available as long as stock exist

G (inch)	Code	SP	Weight (kg)	L (mm)
*	3/4	<b>760 854 717</b>	1	0.246 110



# Manifolds in nonferrous metal

## Manifold 90° - 3/4" (DN 20)

DZR brass suitable for portable water

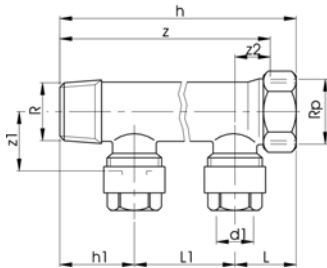

	d (mm)	R (inch)	Rp (inch)	Code	SP	Weight (kg)	L (mm)	L1 (mm)	h (mm)	h1 (mm)	z (mm)	z1 (mm)	z2 (mm)
1-fold	16	3/4	3/4	<b>760 853 189</b>	5	0.220	28	0	59	31	45	24	14
1-fold	20	3/4	3/4	<b>760 853 190</b>	5	0.283	33	0	69	36	55	26	19
2-fold	16	3/4	3/4	<b>760 853 180</b>	5	0.391	28	45	104	31	90	24	14
3-fold	16	3/4	3/4	<b>760 853 181</b>	5	0.561	28	45	149	31	135	24	14
4-fold	16	3/4	3/4	<b>760 853 182</b>	5	0.470	28	45	194	31	180	24	14

## Manifold 90° - 1" (DN 25)

DZR brass suitable for portable water

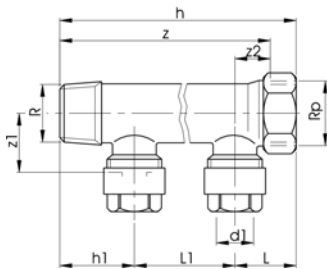

	d (mm)	R (inch)	Rp (inch)	Code	SP	Weight (kg)	L (mm)	L1 (mm)	h (mm)	h1 (mm)	z (mm)	z1 (mm)	z2 (mm)
1-fold	16	1	1	<b>760 854 860</b>	5	0.272	28	0	62	34	45	29	11
1-fold	20	1	1	<b>760 854 855</b>	5	0.344	33	0	75	42	58	29	16
2-fold	16	1	1	<b>760 854 861</b>	1	0.468	28	45	107	34	90	29	11
2-fold	20	1	1	<b>760 854 892</b>	5	0.636	33	60	135	42	118	29	16
3-fold	16	1	1	<b>760 854 862</b>	1	0.678	28	45	152	34	135	29	11
4 fold	16	1	1	<b>760 854 863</b>	1	0.877	28	45	197	34	180	29	11

## Accessories for compression joint fittings



### Union nut

d (mm)	Code	SP	Weight (kg)
16	<b>760 853 018</b>	5	0.034
20	<b>760 853 071</b>	2	0.047

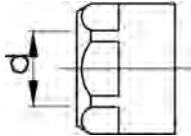

### Clamping ring

d (mm)	Code	SP	Weight (kg)
16	<b>760 853 019</b>	5	0.011
20	<b>760 853 072</b>	2	0.016

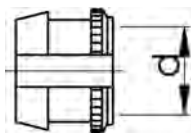

### Cap

Including seal

d (mm)	Code	SP	Weight (kg)
16	<b>760 853 110</b>	5	0.051
20	<b>760 853 150</b>	5	0.094

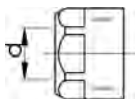

### Seal for cap

Material: Tesnit UNI blue, free of asbestos according to DIN 3754

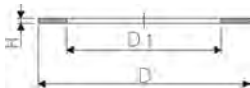

d-d (mm)	Code	SP	Weight (kg)	D (mm)	D1 (mm)	H (mm)
16 - 20	<b>760 853 021</b>	5	0.002	15	6	3



### End Cap

Rp (inch)	Code	SP	Weight (kg)
3/4	<b>760 853 794</b>	5	0.084
1	<b>760 853 706</b>	5	0.135

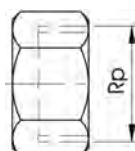





### Long cap

Rp (inch)	Code	SP	Weight (kg)	D (mm)	L (mm)
¾	<b>760 853 596</b>	5	0.162	27	34
1	<b>760 853 527</b>	5	0.216	32	34

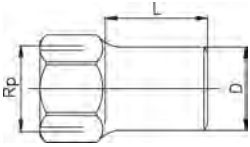

### Plug

R (inch)	Code	SP	Weight (kg)
¾	<b>760 853 792</b>	5	0.050
1	<b>760 853 793</b>	5	0.084

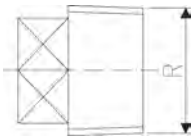

### Long plug

R (inch)	Code	SP	Weight (kg)	D (mm)	L (mm)
¾	<b>760 869 989</b>	5	0.150	27	52
1	<b>760 869 990</b>	5	0.211	33	54

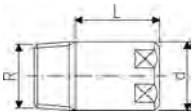



## UNI-Flex L PN16

### Model:

- Housing, Bars and Strip insert (option): Stainless Steel W5 (1.4571) Quality

### Temperature/Pressure:

- Operating temperature EPDM: -30°C to 125°C
- Operating temperature NBR: -20°C to 80°C
- Operating temperature Silicone or Viton on request

### Remark:

- For safe installation on PE/PP/PB pipe use insert stiffeners

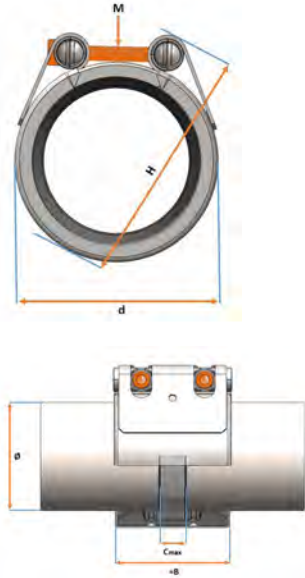

OD nominal (mm) (mm)	EPDM Code	SP	Weight (kg)	NBR Code	SP
21.3 - 21.6	779 812 001	10	0.2	779 809 001	0
26.9 - 28.0	779 812 002	10	0.2	779 809 002	0
30.0	779 812 003	10	0.2	779 809 003	0
33.7 - 35.0	779 812 004	10	0.2	779 809 004	0
38.0	779 812 005	10	0.4	779 809 005	0
42.4	779 812 006	10	0.4	779 809 006	0
44.5	779 812 007	10	0.4	779 809 007	0
48.3	779 812 008	10	0.4	779 809 008	0
54.0 - 57.0	779 812 009	10	0.6	779 809 009	0
60.3 - 63.0	779 812 010	10	0.6	779 809 010	0
66.6 - 70.0	779 812 011	10	1.0	779 809 011	0
73.0 - 79.5	779 812 012	10	1.0	779 809 012	0
84.0	779 812 013	10	1.0	779 809 013	0
88.9	779 812 014	10	1.0	779 809 014	0
98.0 - 104.0	779 812 015	10	1.1	779 809 015	0
104.8 - 110.0	779 812 016	10	1.1	779 809 016	0
114.3 - 118.0	779 812 017	10	1.2	779 809 017	0
125.0 - 129.0	779 812 018	10	1.2	779 809 018	0
130.2 - 133.0	779 812 019	5	2.1	779 809 019	0
139.7 - 141.6	779 812 020	5	2.2	779 809 020	0
154.0 - 155.0	779 812 021	5	2.3	779 809 021	0
159.0	779 812 022	5	2.3	779 809 022	0
165.0 - 168.3	779 812 023	5	2.4	779 809 023	0

OD nominal (mm) (mm)	M	PN (bar)	WP (bar)	C max. (mm)	OD min (mm)	OD max. (mm)	d (mm)	B (mm)	H (mm)
21.3 - 21.6	M6	16	25	10	21.0	24.0	46	45	76
26.9 - 28.0	M6	16	25	10	26.0	29.0	46	45	76
30.0	M6	16	25	10	29.0	32.0	54	45	84
33.7 - 35.0	M6	16	25	10	33.0	36.0	54	45	84
38.0	M8	16	25	15	36.0	39.0	66	60	104
42.4	M8	16	25	15	39.0	43.0	66	60	104
44.5	M8	16	25	15	43.0	47.5	74	60	112
48.3	M8	16	25	15	47.5	52.5	74	60	112
54.0 - 57.0	M8	16	25	25	52.5	58.0	85	75	125
60.3 - 63.0	M8	16	25	25	58.0	64.0	85	75	125
66.6 - 70.0	M10	16	25	30	64.0	72.0	108	95	164
73.0 - 79.5	M10	16	25	30	72.0	80.0	108	95	164
84.0	M10	16	25	30	80.0	88.0	124	95	170
88.9	M10	16	25	30	88.0	96.0	124	95	170
98.0 - 104.0	M10	16	25	30	97.0	105.0	141	95	187
104.8 - 110.0	M10	16	25	30	104.0	112.0	141	95	187
114.3 - 118.0	M10	16	25	30	112.0	120.0	158	95	202
125.0 - 129.0	M10	16	25	30	122.0	130.0	158	95	202
130.2 - 133.0	M12	16	25	40	129.0	137.0	178	110	230

table continued on the next page



OD nominal (mm)	M	PN (bar)	WP (bar)	C max. (mm)	OD min (mm)	OD max. (mm)	d (mm)	B (mm)	H (mm)
139.7 - 141.6	M12	16	25	40	137.0	145.0	186	110	238
154.0 - 155.0	M12	16	25	40	149.0	157.0	197	110	249
159.0	M12	16	25	40	157.0	165.0	205	110	255
165.0 - 168.3	M12	16	25	40	164.0	172.0	212	110	262

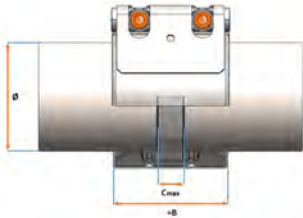

### UNI-Flex S PN16

#### Model:

- Housing, Bars and Strip insert (option): Stainless Steel W5 (1.4571) Quality

#### Temperature/Pressure:

- Operating temperature EPDM: -30°C to 80°C
- Operating temperature NBR: -20°C to 80°C
- Operating temperature Silicone or Viton on request

#### Remark:

- For safe installation on PE/PP/PB pipe use insert stiffeners



OD nominal (mm)	EPDM Code	SP	Weight (kg)	NBR Code	SP
211.0 - 222.0	<b>779 864 026</b>	1	5.3	<b>779 862 026</b>	0
224.0 - 234.0	<b>779 864 027</b>	1	5.5	<b>779 862 027</b>	0
315.0 - 327.0	<b>779 864 034</b>	1	8.2	<b>779 862 034</b>	0

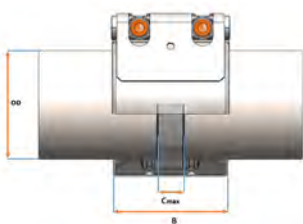

OD nominal (mm)	M	PN (bar)	WP (bar)	C max. (mm)	OD min (mm)	OD max. (mm)	d (mm)	B (mm)	H (mm)
211.0 - 222.0	M12	16	25	40	213	223	261	140	287
224.0 - 234.0	M12	16	25	40	224	234	272	140	298
315.0 - 327.0	M16	16	25	40	318	328	366	142	392

### Insert stiffener Economy

#### Model:

- Suitable for PE, PP and PB pipes
- Stainless steel A2 quality (AISI 304)
- For pipe sizes > d355 use an insert stiffener with wedge
- Other dimensions available on request



Code	SP	Weight (kg)	SDR	L (mm)	d x e (mm)
<b>779 901 303</b>	0	0.100	11.0	100	40 x 3,7
<b>709 026 203</b>	0	0.095	11.0	100	50 x 4,6
<b>709 026 206</b>	0	0.102	17.6 / 17.0	100	50 x 2,9

table continued on the next page

Code	SP	Weight (kg)	SDR	L (mm)	d x e (mm)
709 026 211	0	0.121	11.0	100	63 x 5,8
709 026 214	0	0.132	17.6 / 17.0	100	63 x 3,6
709 026 220	0	0.152	11.0	100	75 x 6,8
709 026 223	0	0.158	17.6 / 17.0	100	75 x 4,3
709 026 230	0	0.210	11.0	120	90 x 8,2
709 026 233	0	0.227	17.6 / 17.0	120	90 x 5,2
709 026 242	0	0.257	11.0	120	110 x 10,0
709 026 245	0	0.279	17.6 / 17.0	120	110 x 6,3
709 026 254	0	0.293	11.0	120	125 x 11,4
709 026 257	0	0.317	17.6 / 17.0	120	125 x 7,2
709 026 266	0	0.383	11.0	140	140 x 12,7
709 026 269	0	0.416	17.6 / 17.0	140	140 x 8,0
709 026 278	0	0.655	11.0	140	160 x 14,6
709 026 281	0	0.711	17.6 / 17.0	140	160 x 9,1
709 026 290	0	0.739	11.0	140	180 x 16,4
709 026 408	0	0.801	17.0	140	180 x 10,7
709 026 293	0	0.804	17.6	140	180 x 10,3
709 026 302	0	0.940	11.0	160	200 x 18,2
709 026 409	0	1.018	17.0	160	200 x 11,9
709 026 305	0	1.024	17.6	160	200 x 11,4
709 026 314	0	1.060	11.0	160	225 x 20,5
709 026 410	0	1.146	17.0	160	225 x 13,4
709 026 317	0	1.155	17.6	160	225 x 12,8
709 026 326	0	1.567	11.0	160	250 x 22,8
709 026 411	0	1.697	17.0	160	250 x 14,8
709 026 329	0	1.705	17.6	160	250 x 14,3
709 026 338	0	1.760	11.0	160	280 x 25,5
709 026 340	0	1.904	17.0	160	280 x 16,6
709 026 341	0	1.914	17.6	160	280 x 16,0
709 026 350	0	1.979	11.0	160	315 x 28,7
709 026 413	0	2.144	17.0	160	315 x 18,7
709 026 353	0	2.157	17.6	160	315 x 17,9
709 026 362	0	2.324	11.0	160	355 x 32,3
709 026 414	0	2.416	17.0	160	355 x 21,1
709 026 365	0	2.431	17.6	160	355 x 20,2

### Screw for plate



For pipe outlets without box  
From the INSTAFLEX range

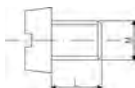

M (mm)	Code	SP	Weight (kg)	L (mm)
6	760 853 022	100	0.004	8
6	760 856 040	100	0.005	self tapping 16

### Cap chromium, to valve PB concealed



d-d (mm)	Code	SP	Weight (kg)	D (mm)
20 - 32	760 853 786	1	0.033	68

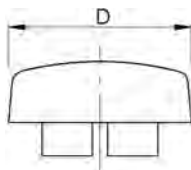

# INSTAFLEX

## Machines and Tools



GF Piping Systems  
Cutting Machine CMB 225



Electro fusion

134



Socket fusion

137



General tools

140



Tools for compression joints

144

## Electro fusion



### Electro fusion control unit-Type HWSG-3

Technical data: Voltage 230V, Power max 1400W, Frequency 50/60Hz, Protection class IP 54, Main connection (3m) with EU-Standard plug  
\* only for CH / swiss plug

	d-d (mm)	Code	SP	Weight (kg)	Dimensions (mm)	Size (mm)
	16 - 110	<b>761 069 021</b>	1	4.142	294	324
*	16 - 110	<b>761 069 020</b>	1	4.047	294	324



### Electro fusion control unit-Type HWSG-3 - 110V

Including welding cable for fittings without tool case, primary cable 110V, primary cable 230V  
Primary cable (3m) with Euro standard plug EU-Standard plug  
Technical data: voltage 110V and 230V variable, power output max. 1500W  
Technical specifications: frequency 47/65Hz, protection rate IP54, incl. power-supply cable 110V and 230V (3m) with EU-Standard plug  
\* on request

	d-d (mm)	Code	SP	Weight (kg)	Dimensions (mm)	Size (mm)
*	16 - 110	<b>761 069 015</b>	1	11.500	294	324



### Primary cable 110V

\* on request

	Code	SP	Weight (kg)	Length (m)
*	<b>761 069 012</b>	1	0.400	3



### Primary cable 230V

\* on request

	Code	SP	Weight (kg)	Length (m)
*	<b>761 069 013</b>	1	0.380	3



### Welding cable PUR straight - HWSG-3 - 110V

Matches to HWSG-3 - 110V  
\* on request

	d-d (mm)	Code	SP	Weight (kg)	Length (m)
	16 - 110	<b>761 069 011</b>	1	0.271	3





### Welding cable angle PUR - HWSG-3 - 110V

Matches to HWSG-3 - 110V  
\* on request

	d (mm)	Code	SP	Weight (kg)	Length (m)
*	16 - 110	<b>761 069 016</b>	1	0.264	3



### Welding cable angle - HWSG-3 - 230V

Matches to HWSG-3 - 230V

	d (mm)	Code	SP	Weight (kg)	Length (m)
	16 - 110	<b>761 069 006</b>	1	0.246	3



### Welding cable straight - HWSG-3 - 230V

Matches to HWSG-3 - 230V

	d (mm)	Code	SP	Weight (kg)	Length (m)
	16 - 110	<b>761 069 001</b>	1	0.255	3



### Welding cable triple 8 m - HWSG-3 - 230V

Matches to HWSG-3 - 230V  
2 pcs. with cable straight  
1 pc. with cable angle  
\* on request

	Code	SP	Weight (kg)	Length (m)
*	<b>761 069 008</b>	1	1.753	8



**MSA 2 MULTI**  
**Automatic Electrofusion Unit for PE/PP/PVDF/PB**

The MSA 2 MULTI automatic electro fusion unit combines light weight and high efficiency, thanks to its inverter technology. The unit is suitable for welding PE, PP, INSTAFLEX PB d125-225, Fuseal d1 1/2"-12" and PPro-Seal 1/2"-3".

It is robust, safe and ergonomic.

All is meant to simplify the job: the barcode scanner, for long distance reading, the cooling system to joint in series, the icon system, to keep the interaction between user and machine intuitive. The entire welding process is controlled and regulated with energy output compensation depending on ambient temperature and the indication of cooling time.

The unit has 500 protocols permanently stored in the internal memory. The user can copy the fusion reports in an USB stick to print them out in PDF format.

Scope of delivery includes: 1 pair of angle adapter clips 4.0 mm, operating instructions, START/STOP badge, USB memory stick and robust transport case

**Technical Data:**

- Operating temperature: -20°C to +50°C
- Fusion data input mode: bar code, manual
- Mains voltage: 230 V (190V - 265V)
- Mains frequency: 50-60 Hz
- Welding technique: Voltage controlled
- Fittings range: d16-630 mm , 1/2"-12"
- Fusion voltage: 3.6-40 V
- Fusion current: 90 A (max)
- Suggested power generators: 3.5 kVA
- USB Port: Type A
- Protection factor: Class 1 / IP 65
- Mains cable: 4 m
- Fusion cable: 3 m
- Weight: ca. 11.9 kg
- Display: Graphical LCD, adjustable contrast

Type	Code	SP	Weight (kg)
Full package plus mini Welding Book, SeaDrain adapters and barcodes	<b>761 069 007</b>	1	20.000

# Socket fusion

## Socket fusion machine BTM 110



Packed in a wooden case, usable as working table, prism clamp device for pipes, round clamping units for fittings d16-d110, pipe support adjustable. Without heating element. Requires heating element catalogue number 761 066 895

l (mm)	h (mm)	Code	SP	Weight (kg)	h1 (mm)	h2 (mm)	h3 (mm)
867	1191	<b>761 066 894</b>	0	95.000	787	404	728

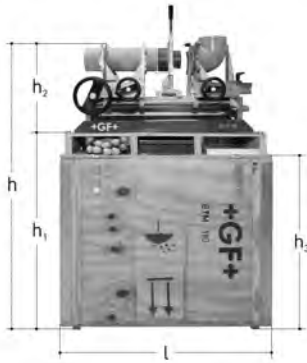

## Accessories for socket fusion machine BTM 110

Toolbox (included in delivery code 761 066 895) heating element with electronic temperature regulation, voltage 230V, power 800W, heating bushes d16-d110, tempil sticks 253°C and 274°C, timer, gtemplate, gloves, support, grip, pipe shears, pipe cutter d32-d110, chamfering tool

Code	SP	Weight (kg)
<b>761 066 895</b>	1	10.000



## Heating element 230V

Scope of delivery: electronic temperature regulation, Voltage 230V, Power 800W, Instruction for the socket fusion jointing  
\* only for CH / swiss plug

	d-d (mm)	Code	SP	Weight (kg)
	16 - 63	<b>761 066 804</b>	1	1.639
*	16 - 63	<b>761 066 751</b>	1	1.646



## Heating element 30° - 230V

Special for weld-in-saddle  
With Schuko-Plug CEE  
\* on request

	D (mm)	Code	SP	Weight (kg)
*	16 - 50	<b>761 066 877</b>	1	1.550



### Support

As a storage possibility for Handheld heating element

Code	SP	Weight (kg)
<b>761 066 801</b>	1	0.986



### Heating bushes

Heating bushes for the entire INSTAFLEX socket fusion range (in conjunction with the BTM 110 fusion machine)

d (mm)	Code	SP	Weight (kg)
16	<b>761 066 756</b>	1	0.189
20	<b>761 066 757</b>	1	0.284
25	<b>761 066 758</b>	1	0.366
32	<b>761 066 759</b>	1	0.369
40	<b>761 066 760</b>	1	0.321
50	<b>761 066 761</b>	1	0.460
63	<b>761 066 762</b>	1	0.609
75	<b>761 066 881</b>	1	1.108
90	<b>761 066 882</b>	1	1.740
110	<b>761 066 883</b>	1	2.450



### Heating bushes for weld-in saddle PB

d = Pipe dim.

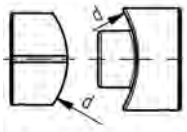

d (mm)	Code	SP	Weight (kg)	Remarks
40	<b>761 068 027</b>	1	0.129	Drill bitt d20-d32
50	<b>761 068 028</b>	1	0.156	Drill bitt d20-d32
63	<b>761 068 029</b>	1	0.199	Drill bitt d20-d32
75	<b>761 068 030</b>	1	0.216	Drill bitt d20-d32
90	<b>761 068 031</b>	1	0.272	Drill bitt d20-d32
110	<b>761 068 032</b>	1	0.298	Drill bitt d20-d32



### Heating bushes for weld-in saddle PB

For heating element straight

d = Pipe dim.

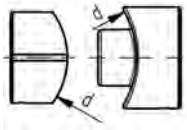

d (mm)	Code	SP	Weight (kg)	Remarks
125	<b>761 068 033</b>	1	0.376	Drill bitt d20-d32
125	<b>761 068 034</b>	1	0.510	Drill bitt d40-d50
160	<b>761 068 035</b>	1	0.568	Drill bitt d20-d32
160	<b>761 068 036</b>	1	0.658	Drill bitt d40-d50
225	<b>761 068 037</b>	1	1.013	Drill bitt d20-d32
225	<b>761 068 038</b>	1	1.019	Drill bitt d40-d50

### Drill bit for weld-in saddle



d (mm)	Code	SP	Weight (kg)
20 - 32	<b>761 068 039</b>	1	0.132
40 - 50	<b>761 068 040</b>	1	0.232

### Fuseal-Template - electro fusion jointing



Dimension (mm)	Code	SP	Weight (kg)
1 1/2" - 6"	<b>761 069 622</b>	1	0.010

### Heating element - complete 230V



Scope of delivery: Metal case, Heating element with electronic temperature regulation Voltage 230V, Power 800W, Heating bushes d16-d63, Tempil sticks 253°C and 274°C, Timer, Template, Gloves, Support, Grip, Pipe shears, Pipe cutter d32-d63, Chamfering tool  
 \* only for CH / swiss plug

d-d (mm)	Code	SP	Weight (kg)
16 - 63	<b>761 066 802</b>	1	11.679
* 16 - 63	<b>761 066 750</b>	1	11.735

## General tools

### Pipe cutting machine CMB225

State-of-the art cutting machine for polyolefin pipes in diameter d110-d230.  
Scope of delivery: Cutting machine CMB 225 (1 pcs.), Machines cutter CW 225 (3 pcs.), Pipe brackets PS 225 (4 pcs.), Wrench for cutter-change (1 pcs.)



Voltage	Code	SP	Weight (kg)
110V	<b>761 070 322</b>	0	38.000
220V	<b>761 070 319</b>	0	38.000



### Cutting insert for CMB 225

d (mm)	Code	SP	Weight (kg)
50 - 110	<b>761 070 323</b>	0	2.000



### Replacement cutting wheels

For plastic pipe cutter

d-d (mm)	Article	Code	SP	Weight (kg)
10 - 63	SR 63 max. s=7,2 mm	<b>790 109 011</b>	50	0.004
50 - 110	SR 110/160 max. s=12,7 mm	<b>790 109 012</b>	50	0.015
110 - 160	SR 160 max. s=19,0 mm	<b>790 109 013</b>	30	0.023



### Machines cutter CW 225

Replacement cutting wheel for cutting machine CMB 225

Cutting depth (mm)	Code	SP	Weight (kg)
26	<b>761 070 320</b>	1	0.240



### Pipe shears

d-d (mm)	Code	SP	Weight (kg)
16 - 25	<b>760 853 279</b>	1	0.295



### Multi-purpose cutter d12/16/20

Made of plastic, blades made of steel, lockable, for cutting protective conduits to the right length as well as for cutting the JRG Sanipex pipes d12/16/20

d-d-d (mm)	GF Code	SP	Weight (kg)	b (mm)	l (mm)
12 - 16 - 20	<b>355 632 424</b>	1	0.150	45	200



### PPC Plastic pipe cutter

For cutting plastic pipes d10 - d160

d-d (mm)	Article	Code	SP	Weight (kg)
10 - 63	PPC 63, s max. = 7.2mm	<b>790 109 001</b>	1	0.865
50 - 110	PPC 110, s max. = 12.7mm	<b>790 109 002</b>	1	1.624
110 - 160	PPC 160, s max. = 19.0mm	<b>790 109 003</b>	1	2.212



### Pipe support

Pipe support for cutting machine CMB 225

d (mm)	Code	SP	Weight (kg)	Type
110 - 225	<b>761 070 321</b>	1	1.500	PS 225
50 - 110	<b>761 070 324</b>	0	1.400	PS 110



### Chamfering tool

d-d (mm)	Code	SP	Weight (kg)
25 - 63	<b>761 066 794</b>	1	0.619
75 - 110	<b>761 066 836</b>	1	0.830



### Spare blades for Chamfering tool

d-d (mm)	Code	SP	Weight (kg)
25 - 110	<b>761 066 795</b>	1	0.016





### Rotary Peeler RS

This innovative Rotary Peeler RS is designed for universal peeling at the pipe end for electrofusion couplings, tees and elbows and as well as for electrofusion saddles. Suitable for peeling PE80, PE100, PEX and PP pipes.

**Features and your advantage:**

**Spring loaded peeling blade:**Peeling quality independent of pipe ovality or tolerances

**Pivoted mounted peeling blade:**To compensate the shape of coiled pipe

**Optimized cutting geometry:**Defined chip thickness with cutting width overlap

**One tool per dimension:**Minimized swivel radius for peeling in narrow locations

**Peeling length:**No limitation of peeling length

**Guidance rolls:**3-point-support for dimensional optimized cutting feed

**Time saving:**Tool is always ready for use, it can be used for the next peeling without having to set the peeling blade back in its origin position

**Your advantage:**Time saving and highest repeatable peeling quality at smallest rotation radius. No operator errors possible when changing dimension

**Included:**1 x Rotary Peeler RS, Transport case, Operating manual, Spare parts list

Article	d (mm)	Code	SP	Weight (kg)
RS 125	125	<b>790 136 007</b>	1	1.730
RS 225	225	<b>790 136 012</b>	1	2.030
RS 315	315	<b>790 136 015</b>	1	2.440



### Template for fusion joints

To mark the coupler

d-d (mm)	Code	SP	Weight (kg)
16 - 63	<b>761 066 800</b>	1	0.014



### KS Tangit Cleaner

- Special cleaner for plastic fusion connections in the material of PP, PE, PVDF and PB
- DVGW approved
- DW 5290 BR 0464

Size	Code	SP	Weight (kg)
1 liter	<b>799 298 023</b>	8	0.872



### Tangit KS-Cleaning Tissues

- Special cleaner for plastic fusion connections in the material of PP, PE, PVDF and PB
- DVGW approved
- DW 5290 BR 0464

Contents	Code	SP	Weight (kg)
1 dispenser with 100 tissues	<b>799 298 024</b>	8	0.333



## IM 315 Butt fusion machine for industrial applications

- Butt fusion machine for PP, PE, PB and PVDF pipes and fittings for industrial applications with pressure piping systems.
- Extremely sturdy design for use in the workshop and on job sites.
- Designed to provide the highest flexibility to adapt to different sizes or shapes of fittings.
- Angular jointing provided up to 30° (2x15°) for prefabrication of segmented fittings.
- Dimensional range: d90-315 mm, from SDR 41 up to SDR 11 with PE,PP d315 mm
- 115 V on request!
- **BASE MACHINE**
- High precision, distortion-free and robust machine base
- Integrated swivel tables for angular jointing up to 30° (2x15°)
- Handwheel for easy moving of machine carriage
- Exact pressure adjustment via direct spring load transfer
- Fusion pressure is maintained with a user friendly fast-locking handle
- Inner left and right clamping elements, for picking up reduction clamping inserts d 90-315 mm, with fast-locking handle
- Optional outer, horizontally removable clamping devices available
- Weight (including planer and heater): 169 kg
- **PLANER**
- Optimized cutting geometry for even and chatter-free planing
- Swivel mounted for ergonomic handling
- Mechanical stop to provide single sided planing and defined facing depth
- Integrated safety switch to prevent unintentional start-up
- Self-locking mechanism in working position
- **HEATER**
- High-performance and precision heater with electronic temperature control (2500W)
- High accuracy of +/- 4°C over the entire heating surface
- High quality, non-stick PTFE coating
- Pull-off mechanism to automatically detach the heating plate from pipe ends
- Metal sheet cover to protect the heating plate in idle position
- Integrated thermometer for fast visual check of plate temperature
- **ADDITIONAL STANDARD EQUIPMENT**
- Reduction clamping inserts set d 90-315 mm
- Pipe supports for picking up reduction supporting inserts d 90-315 mm
- Reduction pipe supporting inserts set d 90-315 mm
- Timer to clock fusion times
- Machine specific tool set

d-d (mm)	Performance	Description	Code	SP	Weight (kg)
90 - 315	230 V / 3500 W	Without transport crate	<b>790 143 005</b>	0	152.000
90 - 315	230 V / 3500 W	With standard transport crate	<b>790 143 001</b>	0	152.000
90 - 315	230 V / 3500 W	With special transport crate	<b>790 143 003</b>	0	366.000



### 1 Set planer blades

- Blade has 2 cutting edges (1 set = 2 blades)

d-d (mm)	Code	SP	Weight (kg)
75 - 250	<b>790 115 024</b>	0	0.083

## Tools for compression joints



### Assembly tongs

d (mm)	Code	SP	Weight (kg)
16 - 20	<b>760 853 743</b>	1	0.503
25	<b>760 869 950</b>	1	0.418



### Ratched spanner

For tightening and loosening of compression fittings d16 and d20

d (mm)	SW (mm)	Code	SP	Weight (kg)
16	24	<b>760 854 916</b>	1	0.280
20	27	<b>760 854 917</b>	1	0.321



### Ball-head socket wrench - crossbar handle

d-d (mm)	Code	SP	Weight (kg)	SW (mm)
16 - 63	<b>761 066 843</b>	2	0.038	3
75 - 110	<b>761 066 844</b>	2	0.038	4



### Spanner

Tool to change the heating bushes

SW (mm)	Code	SP	Weight (kg)
6	<b>760 854 906</b>	1	0.038



### 1/4" screwdriver bit - ball-head

d-d (mm)	Code	SP	Weight (kg)	SW (mm)
16 - 63	<b>761 066 845</b>	5	0.007	3
75 - 110	<b>761 066 846</b>	5	0.007	4



### Template, Electrofusion - HWS

d-d (mm)	Code	SP	Weight (kg)
16 - 110	<b>761 069 602</b>	1	0.065



### Tempil sticks

Temperature (°C)	Code	SP	Weight (kg)	Color
253	<b>761 066 796</b>	1	0.012	yellow
274	<b>761 066 797</b>	1	0.014	red



### Marker

For plastic pipes and fittings

Type	Code	SP	Weight (kg)
Black	<b>761 070 325</b>	10	0.010



### Gloves

Code	SP	Weight (kg)
<b>761 066 799</b>	1	0.115



### Timer with 2 stop times

Code	SP	Weight (kg)
<b>790 114 028</b>	1	0.088



# Seminar- and training documents

Samples







## Technical manuals jointing technologies

This document is digital available on our website  
For high resolution pictures for your seminar or your presentation, please ask your local sales agent

Description	Code	SP	d (mm)	Size
Electro fusion HWS	<b>760 809 081</b>	1	16-110	DIN A5
Electro fusion	<b>760 809 084</b>	1	125, 160, 225	DIN A5
Socket fusion HMS	<b>760 809 085</b>	1	16-110	DIN A5
System valve BTV 2	<b>760 809 086</b>	1	20-63	DIN A5

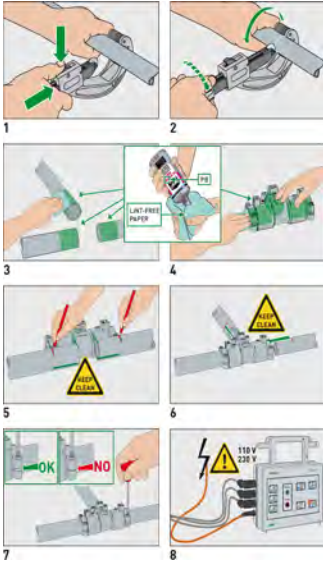

## Current product range INSTAFLEX / iFIT

This document is digital available on our website

Size	Code	SP
DIN A4	<b>760 809 100</b>	1



## Jointing technology sample

Compression joint / electro fusion / socket fusion

d (mm)	Code	SP	Weight (kg)
16 - 40	<b>760 854 994</b>	1	0.823



# iFIT

















# System Overview iFIT

iFIT – the innovative push fit jointing system for heating and plumbing with a safety check you can see and hear. Never before have polybuten and multilayer pipes been so easy, fast and safe to install in the dimensions 16, 20, 25 and 32.



GF Piping Systems  
Product Movie iFIT

	Pipes	157
	Accessories for pipes	159
	Adapters	160
	Modules	161
	Valves	164
	Transition modules	168
	Accessories for modules	171
	Outlet joints	171
	Accessories for outlet joints	175
	WC connection modules	179
	Manifolds	180
	Accessories for manifolds	181
	Heating assortment	182
	Tools	185

# Working with iFIT

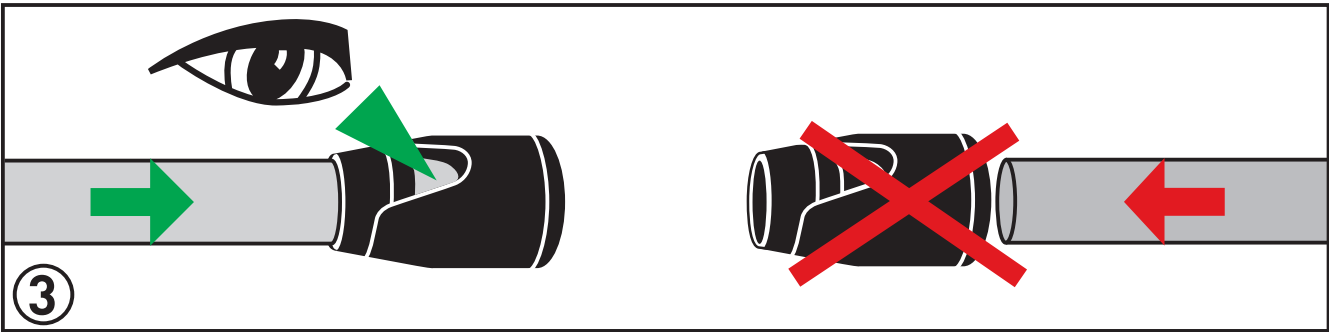
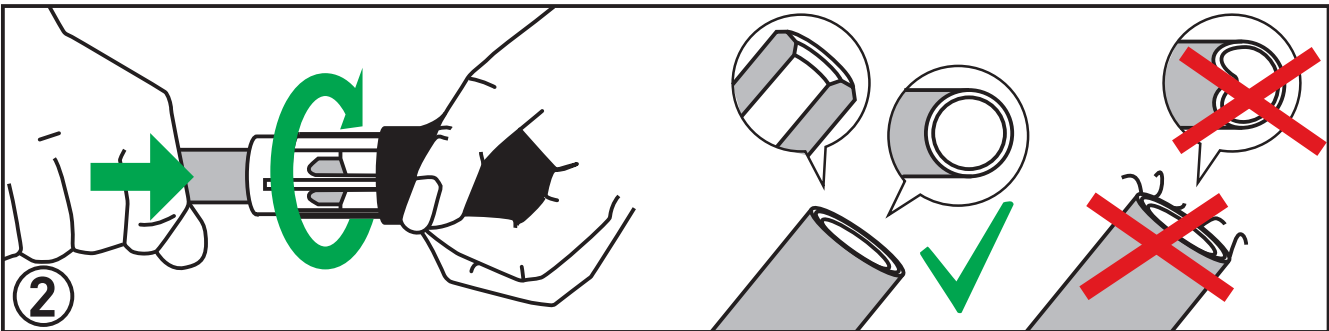
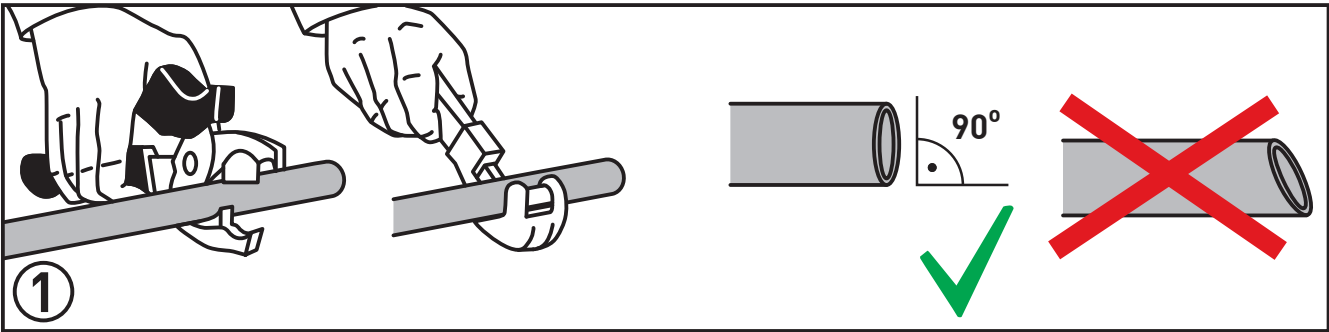

# Approvals iFIT

## + LAND-BASED



**AENOR**  
Spanish Association for  
Standardisation and Certification

001/005182  
001/005183  
001/006239



**ÖVGW**  
Österreichische Vereinigung für das  
Gas- und Wasserfach, Austria

W 4.425  
W 1.424



**aTg (BCCA)**  
Belgian Construction Certification  
Association

13/ 2723



**SVGW**  
Schweizerische Verein des Gas- und  
Wasserfaches, Switzerland

W 0406 - 4834



**DVGW**  
Deutscher Verein des Gas- und  
Wasserfaches e.V., Germany

DW-850BP0047  
DW-8501BP0059



**VKF**  
Vereinigung Kantonalen Feuer-  
versicherungen, Switzerland

24759  
24757



**kiwa**  
Kiwa N.V., Netherlands

K48947/01  
K44842/02  
K44843/02  
K44872/02



**SP (SITAC)**  
Sveriges Tekniska Forskningsinstitut,  
Sweden

0070/05

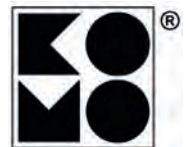

**KOMO**  
KOMO N. V., Netherlands Postbus 70  
2280 AB Rijswijk

K44871/02  
K44872/02



**WRAS**  
Water Regulation Advisory Scheme,  
England

1312518  
1403329

# Approvals iFIT

## + MARINE



**ABS**  
American Bureau of Shipping

15-GD1360685-PDA



**RINA**  
Royal Institution of Naval Architects,  
England

MAC032314CS/001



**DNV-GL**  
Det Norske Veritas- Germanischer  
Lloyd, Norway

K-5897  
25856-05HH



**BV**  
Bureau Veritas, France

15590/B1 BV



**LR**  
Lloyd's Register, England

TA13007H



**RMROS**  
Russian Maritime Register of  
Shipping

15.40030.250



# Technical Data

## Pressure loss chart iFIT (10°)

### Pressure loss chart for iFIT PB- and ML pipes:

#### Pipe friction loss in relation to flow rate

#### Basis of calculation:

Water temperature	= 10°C
Surface roughness $k$	= 0.007 mm
Viscosity	= 0.00131 Pa·s
Density $\rho$	= 999.70 kg/m <sup>3</sup>

#### Recommended flow velocity according SVGW guideline W3/2013:

- max. 4.0 m/s for single outlet lines
- max. 3.0 m/s for apparatus lines
- max. 3.0 m/s for floor distribution lines
- max. 2.0 m/s for distribution lines

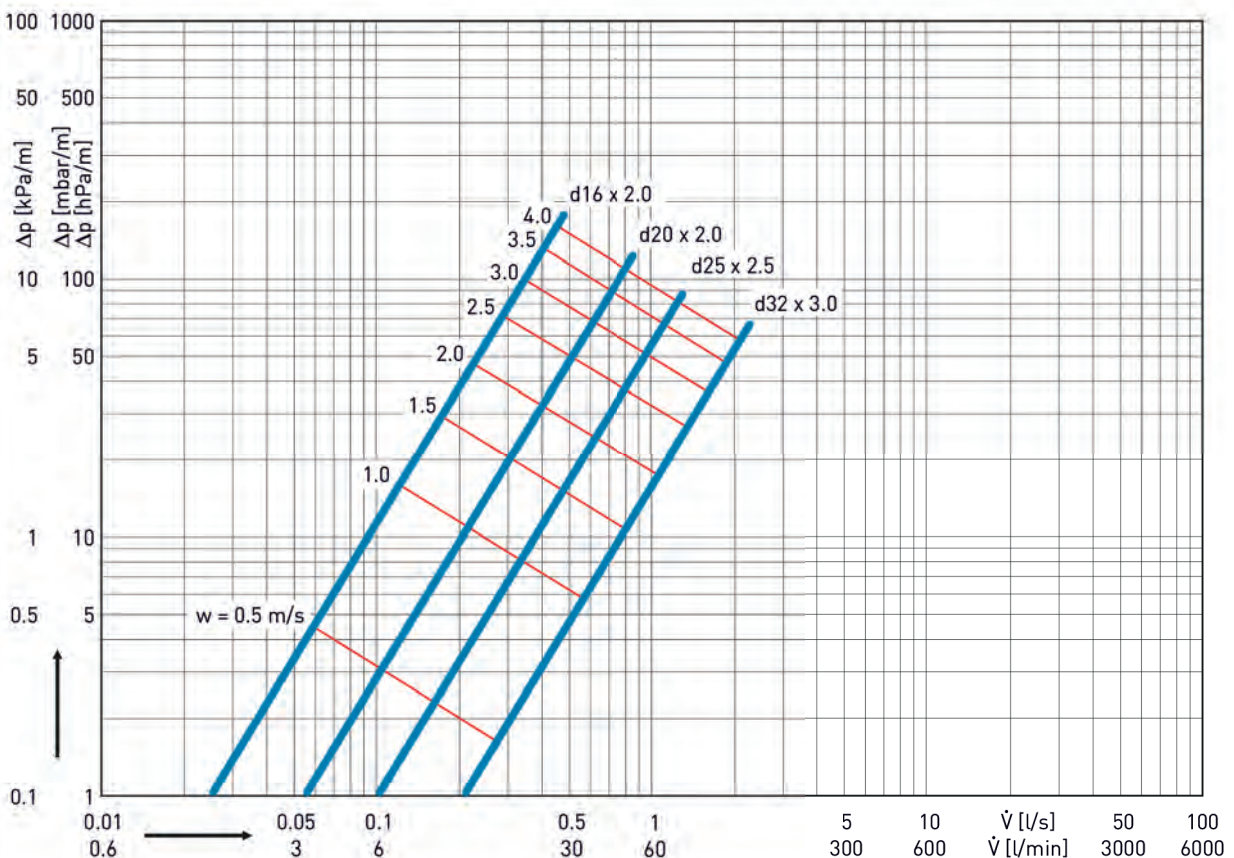



# Technical Data

## Pressure loss chart iFIT (60°)

### Pressure loss chart for iFIT PB- and ML pipes:

#### Pipe friction loss in relation to flow rate

#### Basis of calculation:

Water temperature	= 60°C
Surface roughness $k$	= 0.007 mm
Viscosity	= 0.00013 Pa·s
Density $\rho$	= 983.19 kg/m <sup>3</sup>

#### Recommended flow velocity according SVGW guideline W3/2013:

- max. 4.0 m/s for single outlet lines
- max. 3.0 m/s for apparatus lines
- max. 3.0 m/s for floor distribution lines
- max. 2.0 m/s for distribution lines

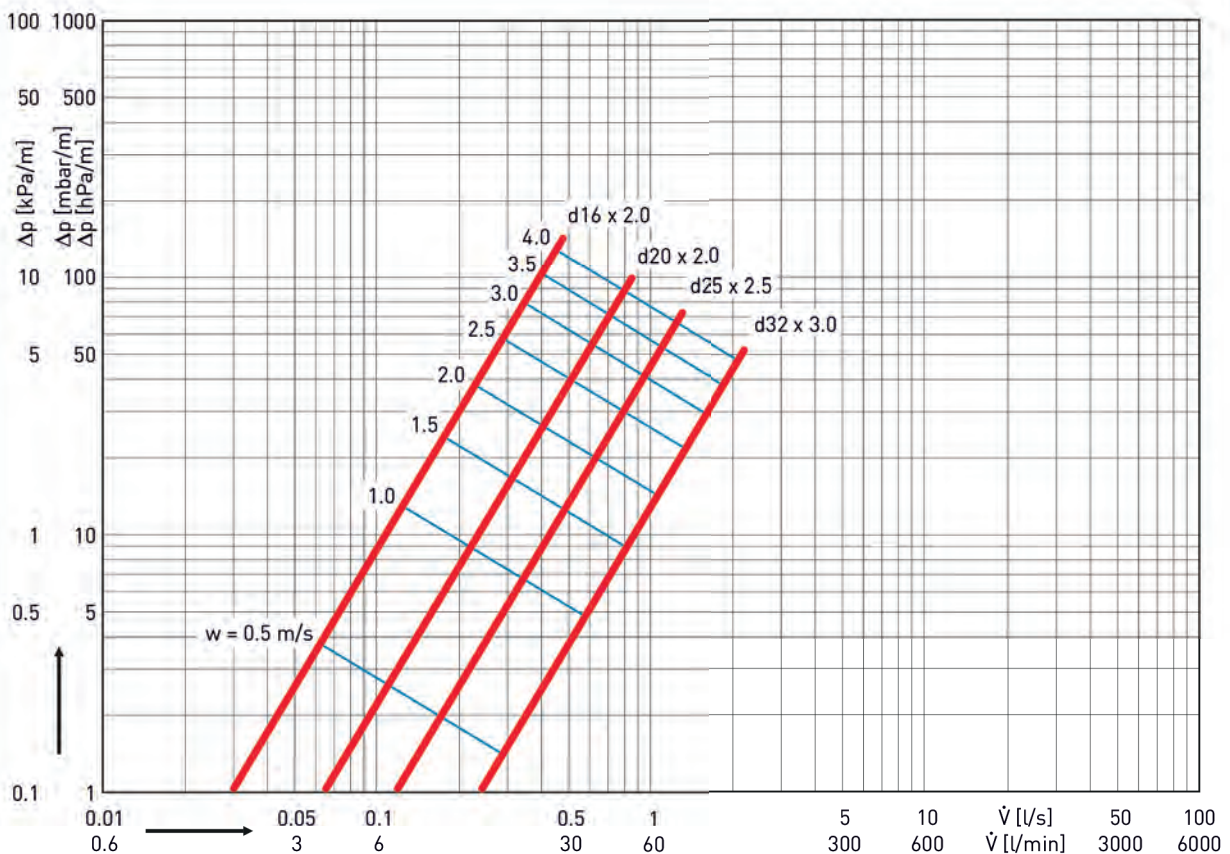

# Pipes



## Polybutene pipe (coiled)

Packed in cardboard boxes  
PB pipe in coils without protective pipe  
Without oxygen barrier  
\* on request

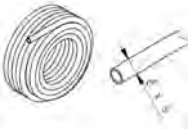

	d (mm)	s (mm)	Code	SP	Weight (kg)
	16	2.0	<b>762 101 126</b>	60	0.088
*	16	2.0	<b>762 101 201</b>	300	0.088
	20	2.0	<b>762 101 127</b>	60	0.115
	25	2.5	<b>762 101 128</b>	30	0.178



## Polybutene pipe in protective pipe (coiled)

Packed in cardboard boxes  
PB pipe in coils in protective pipe  
Without oxygen barrier



	d (mm)	s (mm)	Code	SP	Weight (kg)	D (mm)
	16	2.0	<b>762 101 012</b>	60	0.164	25
	20	2.0	<b>762 101 013</b>	60	0.207	30
	25	2.5	<b>762 101 011</b>	30	0.286	34



## Polybutene pipe 5,0 m (bars)

Packed in cardboard boxes  
Without oxygen barrier  
\* on request



	s (mm)	d (mm)	Code	SP	Weight (kg)
*	2	16	<b>762 101 160</b>	45	0.088
*	2	20	<b>762 101 161</b>	45	0.115
*	3	25	<b>762 101 162</b>	50	0.178
*	3	32	<b>762 101 163</b>	20	0.272



## Multilayer pipe (coiled)

Packed in cardboard boxes  
Multilayer pipe in coils without protective pipe  
Packed in protective wrap  
\* on request

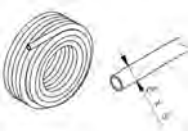

	d (mm)	s (mm)	Code	SP	Weight (kg)
	16	2.0	<b>762 101 000</b>	100	0.119
*	16	2.0	<b>762 101 014</b>	200	0.118
	20	2.0	<b>762 101 001</b>	50	0.154
	25	2.5	<b>762 101 130</b>	50	0.289
	32	3.0	<b>762 101 131</b>	50	0.354



### Multilayer pipe in protective pipe (coiled)

Packed in cardboard boxes  
 Multilayer pipe in coils in protective pipe  
 \* with protective pipe in red  
 \* on request



	d (mm)	s (mm)	Code	SP	Weight (kg)	D (mm)
	16	2.0	<b>762 101 003</b>	75	0.194	25
*	16	2.0	<b>762 101 194</b>	75	0.194	25
	20	2.0	<b>762 101 004</b>	50	0.246	30
*	20	2.0	<b>762 101 195</b>	50	0.246	30



### Multilayer pipe 5,0 m (bars)

Packed in cardboard boxes



	d (mm)	s (mm)	Code	SP	Weight (kg)
	16	2.0	<b>762 101 005</b>	45	0.118
	20	2.0	<b>762 101 006</b>	45	0.154
	25	2.5	<b>762 101 007</b>	50	0.284
	32	3.0	<b>762 101 008</b>	20	0.354



### Multilayer pipe insulated 6 mm (coiled)

Packed in protective wrap  
 Multilayer pipe in coils



	d (mm)	s (mm)	Code	SP	Weight (kg)	d1 (mm)	s1 (mm)
	16	2.0	<b>762 101 024</b>	50	0.150	28	6
	20	2.0	<b>762 101 032</b>	50	0.200	32	6
	25	2.5	<b>762 101 043</b>	25	0.400	37	6



### Multilayer pipe insulated 9 mm (coiled)

Packed in protective wrap  
 Multilayer pipe in coils



	d (mm)	s (mm)	Code	SP	Weight (kg)	d1 (mm)	s1 (mm)
	16	2.0	<b>762 101 076</b>	50	0.230	34	9
	20	2.0	<b>762 101 078</b>	50	0.188	38	9
	25	2.5	<b>762 101 082</b>	25	0.450	43	9



### Multilayer pipe insulated 13 mm (coiled)

Packed in protective wrap  
 Multilayer pipe in coils  
 \* on request



	s (mm)	d (mm)	Code	SP	Weight (kg)	d1 (mm)
*	13	16	<b>762 101 086</b>	50	0.300	42
*	13	20	<b>762 101 090</b>	50	0.400	46
*	13	25	<b>762 101 104</b>	25	0.500	51

## Accessories for pipes



### Wall inlet plug

d (mm)	Code	SP	Weight (kg)
16	<b>762 101 150</b>	1	0.253
20	<b>762 101 151</b>	1	0.257
25	<b>762 101 152</b>	1	0.223
32	<b>762 101 153</b>	1	0.380



### Pipe draw coupling

d (mm)	Code	SP	Weight (kg)
16	<b>762 101 154</b>	1	0.044
20	<b>762 101 155</b>	1	0.090



### Cap for protective pipe

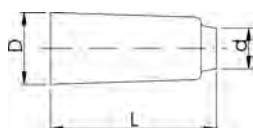

d (mm)	Colors	Code	SP	Weight (kg)	D (mm)	L (mm)
16	red	<b>762 101 234</b>	10	0.006	25	70
16	blue	<b>762 101 235</b>	10	0.005	25	70
20	red	<b>762 101 236</b>	10	0.006	30	70
20	blue	<b>762 101 237</b>	10	0.005	30	70

# Adapters

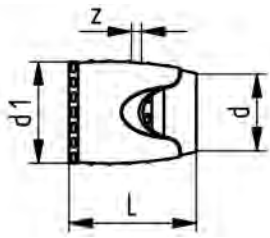

## Adaptor

d (mm)	d1 (mm)	Code	SP	Weight (kg)	L (mm)	z (mm)
16	30	<b>762 101 030</b>	10	0.024	48	5
20	34	<b>762 101 031</b>	10	0.028	49	5
25	45	<b>762 101 034</b>	5	0.067	62	8
32	52	<b>762 101 035</b>	5	0.085	63	8

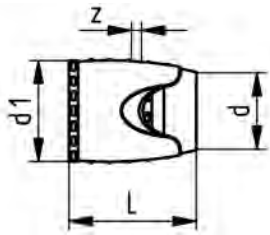

## iFIT-FLEXALINO special adaptor

\* on request

	d (mm)	d1 (mm)	Code	SP	Weight (kg)	z (mm)	l (mm)
*	16	30	<b>762 101 050</b>	10	0.048	5	48



## Cap for adaptor

d (mm)	s (mm)	Code	SP	Weight (kg)
16	2.0	<b>762 101 017</b>	5	0.004
25	2.5	<b>762 101 027</b>	5	0.009

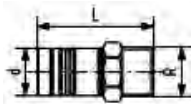

## Male thread adaptor 1/2" - pipe outline

d (mm)	Code	SP	Weight (kg)	L (mm)	R (inch)
20	<b>762 101 238</b>	2	0.064	49	½

# Modules



**Coupler/reducing module**

d (mm)	Code	SP	Weight (kg)	L (mm)	h (mm)
16 - 20	<b>762 101 044</b>	10	0.045	43	22
25 - 32	<b>762 101 175</b>	5	0.023	56	28

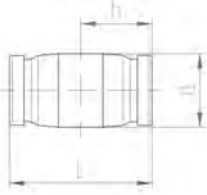

**Reducing module**

d1 (mm)	d2 (mm)	Code	SP	Weight (kg)	L (mm)	h1 (mm)	h2 (mm)
25 - 32	16 - 20	<b>762 101 177</b>	2	0.018	52	32	20

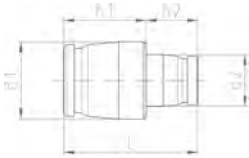

**Elbow module 90°**

d (mm)	Code	SP	Weight (kg)	h (mm)
16 - 20	<b>762 101 046</b>	10	0.013	36
25 - 32	<b>762 101 179</b>	5	0.042	54

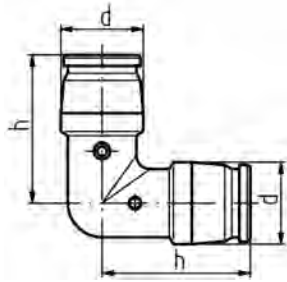



### Elbow module 90° - pipe outline

d (mm)	Code	SP	Weight (kg)	d1 (mm)	h1 (mm)	h (mm)
16 - 20	<b>762 101 202</b>	5	0.013	20	40	36
25 - 32	<b>762 101 203</b>	2	0.030	25	46	54

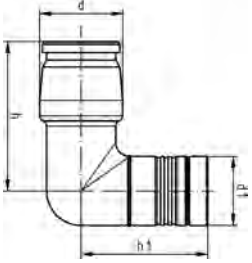

### Elbow module 45°



d (mm)	Code	SP	Weight (kg)	h (mm)
25 - 32	<b>762 101 180</b>	5	0.033	40

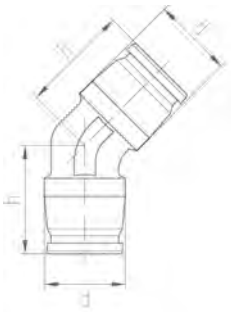

### T-piece module



d (mm)	Code	SP	Weight (kg)	h (mm)	h1 (mm)
16 - 20	<b>762 101 042</b>	10	0.017	31	37
25 - 32	<b>762 101 181</b>	5	0.053	45	54

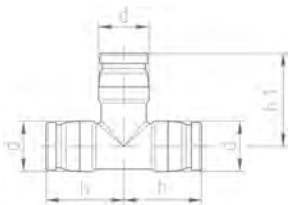





### T-piece module - pipe outline

d (mm)	Code	SP	Weight (kg)	d1 (mm)	h (mm)	h1 (mm)	h2 (mm)
16 - 20	<b>762 101 204</b>	5	0.017	20	41	37	32
25 - 32	<b>762 101 205</b>	2	0.044	25	46	54	45

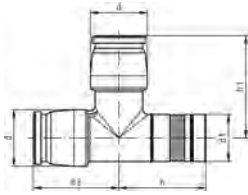

### T- piece module - reduced



d1 (mm)	d2 (mm)	d3 (mm)	Code	SP	Weight (kg)	H1 (mm)	H2 (mm)	H3 (mm)
25 - 32	25 - 32	16 - 20	<b>762 101 183</b>	2	0.045	45	54	39
25 - 32	16 - 20	25 - 32	<b>762 101 185</b>	2	0.044	45	48	45
25 - 32	16 - 20	16 - 20	<b>762 101 187</b>	2	0.036	45	48	39

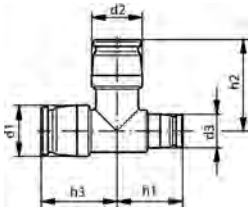

### Y-Module



d (mm)	Code	SP	Weight (kg)	d1 (mm)	h (mm)	A (mm)
16 - 20	<b>762 101 233</b>	5	0.032	20	74	36

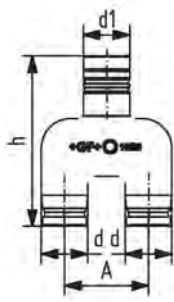

# Valves

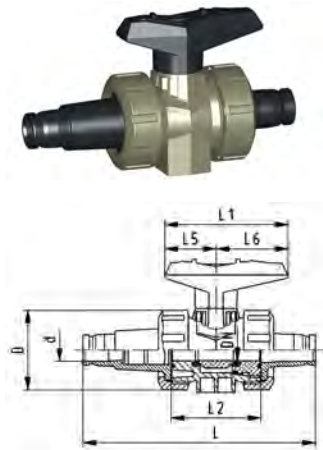

## PROGEF Standard Shipbuilding ball valve type 547 With iFIT connection

### Model:

- Material: PP-H
- iFIT connection for d16/20
- iFIT connector with integrated check valve and filter
- For easy installation and removal
- Ball seals PTFE
- Integrated stainless steel mounting inserts

d	DN	PN	kv-value	EPDM	SP	Weight
(mm)	(mm)	(bar)	( $\Delta p=1$ bar)	Code		(kg)
			(L/min)			
20	15	10	40	167 547 012	2	0.245

d	D	H	H1	H2	L	L1	L2	L4	L5	L6	M
(mm)	(mm)	(mm)	(mm)	(mm)	(mm)	(mm)	(mm)	(mm)	(mm)	(mm)	(mm)
20	50	57	27	12	146	77	56	25	32	45	6

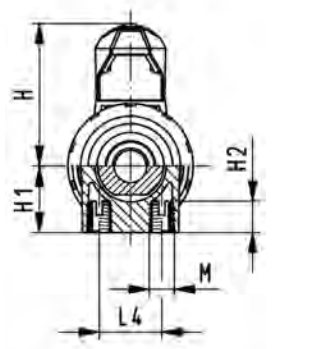

## PROGEF Standard Shipbuilding ball valve type 547 With iFIT connection

### Model:

- Material: PP-H
- iFIT connection for d16/20
- For easy installation and removal
- Ball seals PTFE
- Integrated stainless steel mounting inserts

d	DN	PN	kv-value	EPDM	SP	Weight
(mm)	(mm)	(bar)	( $\Delta p=1$ bar)	Code		(kg)
			(L/min)			
20	15	10	185	167 547 812	2	0.152

d	D	H	H1	H2	L	L1	L2	L4	L5	L6	M
(mm)	(mm)	(mm)	(mm)	(mm)	(mm)	(mm)	(mm)	(mm)	(mm)	(mm)	(mm)
20	50	57	27	12	126	77	56	25	32	45	6

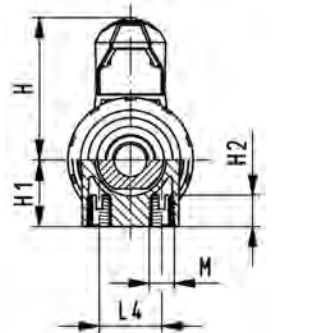
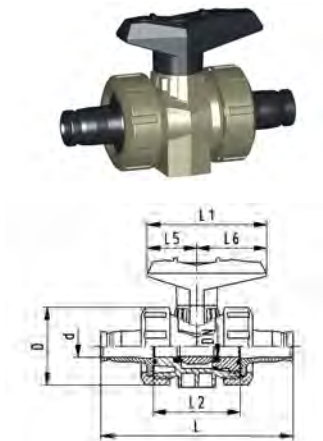

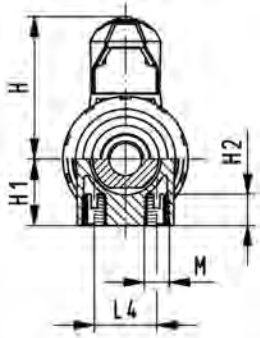
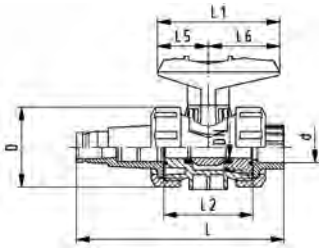

**PROGEF Standard**  
**Shipbuilding ball valve type 547**  
**With iFIT connection and fusion socket PB**

**Model:**

- Material: PP-H
- iFIT connection for d16/20
- iFIT connection with integrated check valve and filter
- For easy installation and removal
- Ball seals PTFE
- Integrated stainless steel mounting inserts

d (mm)	DN (mm)	PN (bar)	kv-value ( $\Delta p=1$ bar) (l/min)	EPDM Code	SP	Weight (kg)
16	10	10	40	<b>167 547 041</b>	2	0.244
20	15	10	40	<b>167 547 042</b>	2	0.242

d (mm)	D (mm)	H (mm)	H1 (mm)	H2 (mm)	L (mm)	L1 (mm)	L2 (mm)	L4 (mm)	L5 (mm)	L6 (mm)	M (mm)
16	50	57	27	12	130	77	56	25	32	45	6
20	50	57	27	12	131	77	56	25	32	45	6

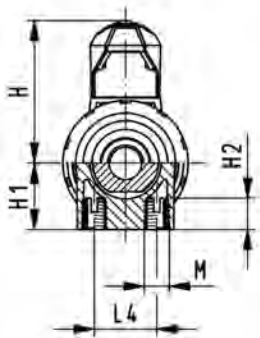
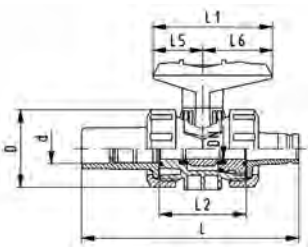

**PROGEF Standard**  
**Shipbuilding ball valve type 547**  
**With fusion socket PB and iFIT connection**

**Model:**

- Material: PP-H
- iFIT connection for d16/20
- For easy installation and removal
- Ball seals PTFE
- Integrated stainless steel mounting inserts
- Fusion socket PB with integrated check valve and filter

d (mm)	DN (mm)	PN (bar)	kv-value ( $\Delta p=1$ bar) (l/min)	EPDM Code	SP	Weight (kg)
16	10	10	40	<b>167 547 311</b>	2	0.303
20	15	10	40	<b>167 547 312</b>	2	0.303

d (mm)	D (mm)	H (mm)	H1 (mm)	H2 (mm)	L (mm)	L1 (mm)	L2 (mm)	L4 (mm)	L5 (mm)	L6 (mm)	M (mm)
16	50	57	27	12	141	77	56	25	32	45	6
20	50	57	27	12	141	77	56	25	32	45	6



**PROGEF Standard**  
**Shipbuilding ball valve type 547**  
**With threaded socket Rp brass and iFIT connection**

**Model:**

- Material: PP-H
- iFIT connection for d16/20
- Threaded socket Rp brass with integrated check valve and filter
- For easy installation and removal
- Ball seals PTFE
- Integrated stainless steel mounting inserts

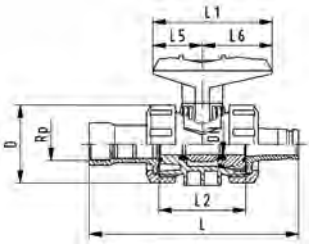

Rp	DN	PN	kv-value	EPDM	SP	Weight
(inch)	(mm)	(bar)	( $\Delta p=1$ bar)	Code		(kg)
1/2	15	10	40	<b>167 547 512</b>	2	0.327

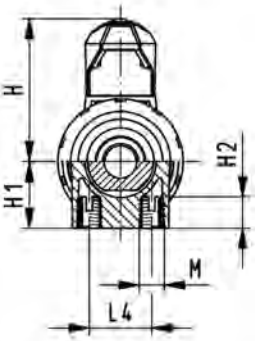

Rp	D	H	H1	H2	L	L1	L2	L4	L5	L6	M
(inch)	(mm)	(mm)	(mm)	(mm)	(mm)	(mm)	(mm)	(mm)	(mm)	(mm)	(mm)
1/2	50	57	27	12	136	77	56	25	32	45	6



**Service housing end connector kit with iFIT connector**

d	Size	DN	Code	SP
(mm)	(inch)	(mm)		
20	1/2	15	<b>167 547 902</b>	1

### Concealed shut-off valve

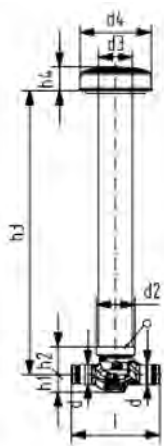

d (mm)	Code	SP	Weight (kg)	d2 (mm)	d3 (mm)	d4 (mm)	h1 (mm)	h2 (mm)	h3 (mm)	h4 (mm)	l (mm)
16 - 20	<b>762 101 227</b>	1	0.300	39	34	71	18	28	43 - 270	24	88
25 - 32	<b>762 101 228</b>	1	0.500	39	34	71	27	28	43 - 270	24	112

### Manifold shut-off valve

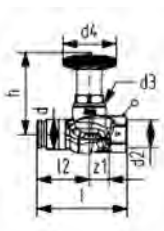

d (mm)	Code	SP	Weight (kg)	d2 Rp (inch)	d3 G (inch)	d4 (mm)	l (mm)	l2 (mm)	h (mm)	z1 (mm)
25 - 32	<b>762 101 229</b>	1	0.440	3/4	3/4	53	90	52	82	23

# Transition modules

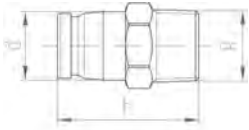

## Transition module - male thread

\* low lead

	d (mm)	R (inch)	Code	SP	Weight (kg)	h (mm)
	16 - 20	½	<b>762 101 038</b>	10	0.061	42
	16 - 20	¾	<b>762 101 039</b>	10	0.078	43
	25 - 32	¾	<b>762 101 091</b>	2	0.144	51
	25 - 32	1	<b>762 101 092</b>	2	0.189	55
*	16 - 20	½	<b>762 101 265</b>	10	0.060	42
*	16 - 20	¾	<b>762 101 266</b>	10	0.078	43
*	25 - 32	¾	<b>762 101 277</b>	2	0.135	51
*	25 - 32	1	<b>762 101 278</b>	2	0.175	55



## Transition module - female thread

\* low lead

	d (mm)	Rp (inch)	Code	SP	Weight (kg)	h (mm)	z (mm)
	16 - 20	½	<b>762 101 040</b>	10	0.067	36	23
	16 - 20	¾	<b>762 101 041</b>	10	0.087	39	24
	25 - 32	¾	<b>762 101 093</b>	2	0.131	45	31
	25 - 32	1	<b>762 101 094</b>	2	0.163	49	32
*	16 - 20	½	<b>762 101 267</b>	10	0.065	36	23
*	16 - 20	¾	<b>762 101 268</b>	10	0.085	39	24
*	25 - 32	¾	<b>762 101 279</b>	2	0.127	45	31
*	25 - 32	1	<b>762 101 280</b>	2	0.175	49	32

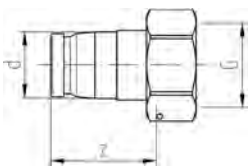

## Transition union module - flat sealed

Supplied with sealing

\*\* on request

\* low lead

	d (mm)	G (inch)	Code	SP	Weight (kg)	z (mm)
**	16 - 20	½	<b>762 101 088</b>	2	0.080	41
	16 - 20	¾	<b>762 101 056</b>	2	0.085	35
	25 - 32	¾	<b>762 101 095</b>	2	0.170	48
	25 - 32	1	<b>762 101 096</b>	2	0.233	55
	25 - 32	1 ¼	<b>762 101 097</b>	2	0.266	48
	25 - 32	1 ½	<b>762 101 098</b>	2	0.339	50
***	16 - 20	½	<b>762 101 276</b>	2	0.080	41
*	16 - 20	¾	<b>762 101 273</b>	5	0.129	35
*	25 - 32	¾	<b>762 101 281</b>	2	0.170	48
*	25 - 32	1	<b>762 101 282</b>	2	0.233	55
*	25 - 32	1 ¼	<b>762 101 283</b>	2	0.266	48
*	25 - 32	1 ½	<b>762 101 284</b>	2	0.339	50

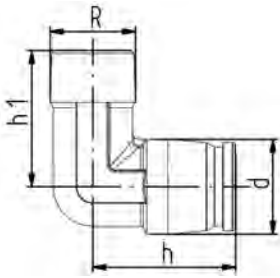

### Transition elbow module - male thread

\* low lead

d (mm)	R (inch)	Code	SP	Weight (kg)	h (mm)	h1 (mm)
16 - 20	1/2	<b>762 101 051</b>	10	0.071	30	34
16 - 20	3/4	<b>762 101 052</b>	10	0.076	30	35
25 - 32	3/4	<b>762 101 099</b>	2	0.189	45	43
25 - 32	1	<b>762 101 100</b>	2	0.214	45	45
* 16 - 20	1/2	<b>762 101 270</b>	10	0.071	30	34
* 16 - 20	3/4	<b>762 101 271</b>	10	0.076	30	35
* 25 - 32	3/4	<b>762 101 285</b>	2	0.189	45	43
* 25 - 32	1	<b>762 101 286</b>	2	0.214	45	45

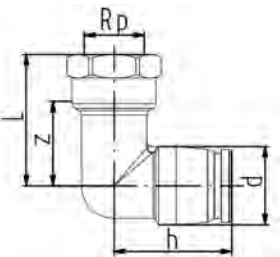

### Transition elbow module - female thread

\* low lead

d (mm)	Rp (inch)	Code	SP	Weight (kg)	L (mm)	h (mm)	z (mm)
16 - 20	1/2	<b>762 101 101</b>	10	0.102	38	32	25
16 - 20	3/4	<b>762 101 105</b>	10	0.120	40	36	22
25 - 32	3/4	<b>762 101 102</b>	5	0.211	50	45	33
* 16 - 20	1/2	<b>762 101 287</b>	10	0.102	38	32	25
* 16 - 20	3/4	<b>762 101 290</b>	10	0.120	40	36	22
* 25 - 32	3/4	<b>762 101 288</b>	5	0.211	50	45	33

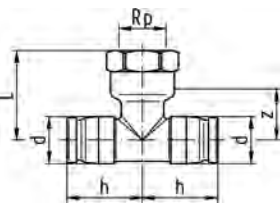

### Transition Tee module - female thread

\* low lead

d (mm)	Rp (inch)	Code	SP	Weight (kg)	L (mm)	h (mm)	z (mm)
16 - 20	1/2	<b>762 101 055</b>	5	0.129	38	32	25
25 - 32	3/4	<b>762 101 103</b>	2	0.291	50	43	35
* 16 - 20	1/2	<b>762 101 272</b>	5	0.129	38	32	25
* 25 - 32	3/4	<b>762 101 289</b>	2	0.291	50	43	35





### Transition module iFIT-INSTAFLEX

Socket fusion transition to iFIT  
 Thread in DZR brass, UBA (Umwelt Bundesamt, Germany) conform  
 EPDM sealing hot and cold water approved

d (mm)	d1 (mm)	Code	SP	Weight (kg)	L (mm)	z (mm)	k max. (mm)
16	16 - 20	<b>762 101 253</b>	1	0.072	93	73	22
20	16 - 20	<b>762 101 254</b>	1	0.085	96	76	23
25	16 - 20	<b>762 101 255</b>	1	0.110	103	83	23
25	25 - 32	<b>762 101 256</b>	1	0.155	108	83	23
32	25 - 32	<b>762 101 257</b>	1	0.213	144	86	21

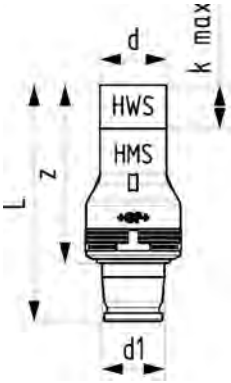

### Transition module - iFIT/copper

\*\* on request  
 \* low lead

d1 (mm)	d2 (mm)	Code	SP	Weight (kg)	z (mm)	
16 - 20	10	<b>762 101 089</b>	10	0.070	22	
16 - 20	12	<b>762 101 210</b>	10	0.052	19	
16 - 20	15	<b>762 101 211</b>	10	0.064	22	
*, **	16 - 20	12	<b>762 101 292</b>	10	0.050	19
*, **	16 - 20	15	<b>762 101 293</b>	10	0.060	22

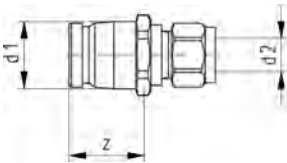

### Transition module - iFIT/JRG Sanipex MT

d1 (mm)	d2 (mm)	Code	SP	Weight (kg)	l (mm)
16 / 20	26	<b>762 101 250</b>	2	0.185	49
16 / 20	32	<b>762 101 251</b>	2	0.300	57
25 / 32	32	<b>762 101 252</b>	2	9.675	64

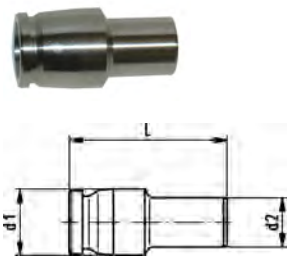

### Transition module - iFIT/press

d1 (mm)	d2 (mm)	Code	SP	Weight (kg)	L (mm)
16 - 20	15	<b>762 101 190</b>	2	0.036	54
16 - 20	18	<b>762 101 191</b>	2	0.037	56
25 - 32	22	<b>762 101 192</b>	2	0.105	70
25 - 32	28	<b>762 101 193</b>	2	0.103	70

## Accessories for modules



### Plug module-side

With air-vent screw 1/2"

d (mm)	Code	SP	Weight (kg)
16 - 20	<b>762 101 207</b>	1	0.140
25 - 32	<b>762 101 208</b>	1	0.196

## Outlet joints



### Single pipe outlet with box

Accessories from the JRG Sanipex product range.

Box brackets, distance plates and other accessories may be found under the catalogue numbers 5409 and 5741.

d (mm)	Rp (inch)	Code	SP	Weight (kg)	H (mm)	h (mm)
16 - 20	1/2	<b>762 101 224</b>	10	0.205	51	50
16 - 20	3/4	<b>762 101 225</b>	10	0.213	51	50

L-Kr. Ø 60

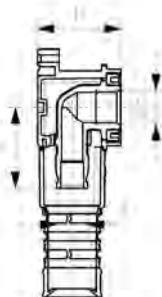

### Dual pipe outlet with box

Accessories from the JRG Sanipex product range.

Box brackets, distance plates and other accessories may be found under the catalogue numbers 5409 and 5741.



d	Rp	Code	SP	Weight	H	h	L
(mm)	(inch)			(kg)	(mm)	(mm)	(mm)
16 - 20	½	<b>762 101 226</b>	1	0.320	51	128	36

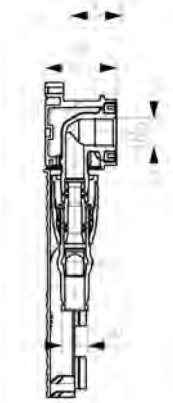
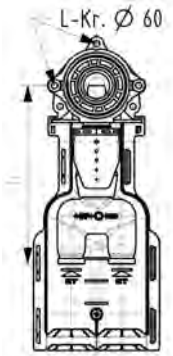



### Single pipe outlet module

Applicable for light and wood construction  
\* low lead

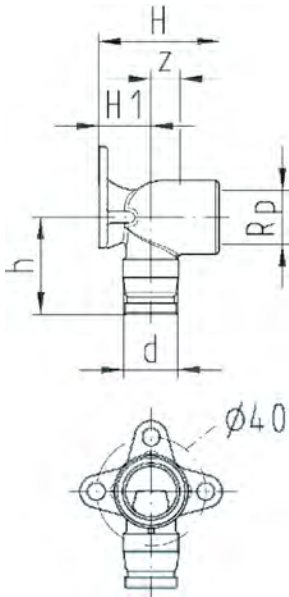

	d (mm)	Rp (inch)	Code	SP	Weight (kg)	H (mm)	H1 (mm)	h (mm)	z (mm)
	16 - 20	½	<b>762 101 018</b>	10	0.153	44	19	36	12
*	16 - 20	½	<b>762 101 259</b>	10	0.153	44	19	36	12
	16 - 20	½	<b>762 101 070</b>	5	0.188	64	19	36	32
*	16 - 20	½	<b>762 101 274</b>	5	0.188	64	19	36	32
	16 - 20	½	<b>762 101 242</b>	2	0.272	95	19	39	63
	16 - 20	¾	<b>762 101 019</b>	2	0.173	44	19	39	11
*	16 - 20	¾	<b>762 101 260</b>	2	0.173	44	19	39	11

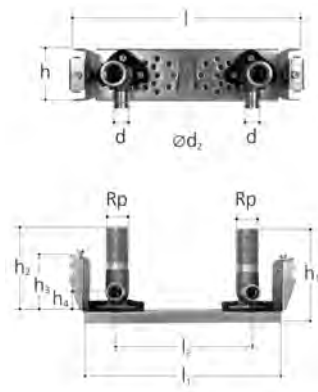

### Plate for GIS profile with iFIT fitting connections

Made of galvanized steel, fitting connections with female thread, pressure plug made of plastic and fixing clip to washbasin, noise absorbing element and sealing gasket made of rubber, suitable for: Geberit system (GIS)

d (mm)	Rp (inch)	Code	SP	Weight (kg)	d2 (mm)	h (mm)	h1 (mm)	h2 (mm)	h3 (mm)	h4 (mm)	l (mm)	l1 (mm)	l2 (mm)
16 - 20	½	<b>762 101 240</b>	1	0.925	10	64	111	98	71	22	248	223	153

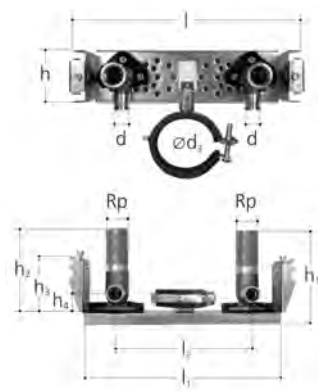

### Plate for GIS profile with drain pipe clamp

Made of galvanized steel, drain pipe clamp, fitting connections with female thread, pressure plug made of plastic and fixing clip to washbasin, noise absorbing element and sealing gasket made of rubber, suitable for: Geberit system (GIS)

d (mm)	Rp (inch)	Code	SP	Weight (kg)
16 - 20	½	<b>762 101 241</b>	1	1.015

d (mm)	Rp (inch)	d2 (mm)	d3 (mm)	h (mm)	h1 (mm)	h2 (mm)	h3 (mm)	h4 (mm)	l (mm)	l1 (mm)	l2 (mm)
16 - 20	½	10	50 - 70	64	111	98	71	22	248	223	153



### Dual pipe outlet module

Applicable for light and wood construction  
\* low lead

	d (mm)	Rp (inch)	Code	SP	Weight (kg)	A (mm)	H (mm)	H1 (mm)	h (mm)	z (mm)
	16 - 20	½	<b>762 101 022</b>	2	0.240	40	44	19	57	12
	16 - 20	½	<b>762 101 071</b>	2	0.282	40	64	19	57	32
*	16 - 20	½	<b>762 101 261</b>	2	0.240	40	44	19	57	12
*	16 - 20	½	<b>762 101 275</b>	2	0.282	40	64	19	57	32

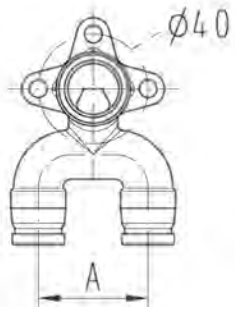
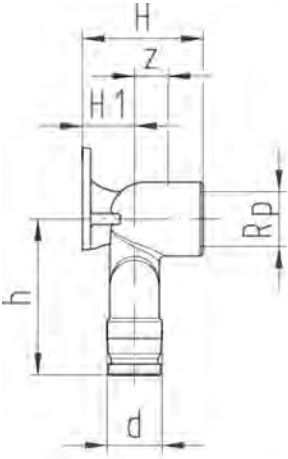

### Single pipe outlet module 1/2" - 3/4"

\* low lead

	d (mm)	Rp (inch)	Code	SP	Weight (kg)	H (mm)	h (mm)	G (inch)	L (mm)
	16 - 20	½	<b>762 101 047</b>	1	0.197	55	42	¾	20
*	16 - 20	½	<b>762 101 269</b>	1	0.197	55	42	¾	20

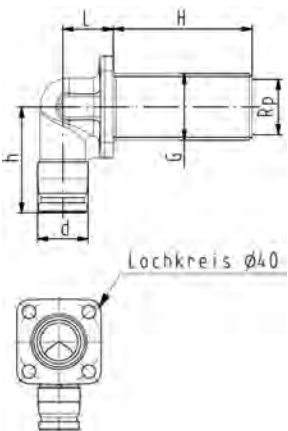

# Accessories for outlet joints

## Mounting bolt



G (inch)	Code	SP	Weight (kg)
1/2	760 853 291	5	0.138

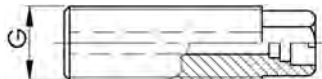

## Wall inlet plug



G (inch)	Code	SP	Weight (kg)
1/2	760 853 297	10	0.088

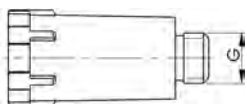

## Fastening sleeve

From the INSTAFLEX range



Rp (inch)	Code	SP	Weight (kg)
1/2	760 853 298	10	0.050



## Bracket for waste pipe



D (mm)	Code	SP	Weight (kg)	H (mm)
56	760 854 677	1	0.032	65 - 80

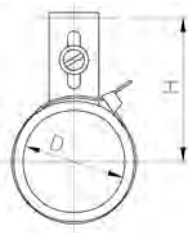

## Installation bar



L (mm)	Code	SP	Weight (kg)
2000	760 853 683	5	2.840



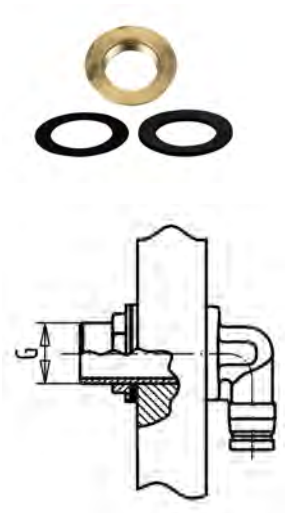

### Fastening set

Appropriate to outlet joint with male thread  
Consists of: Union nut, washer, seal

Code	SP	Weight (kg)
<b>760 854 699</b>	10	0.031

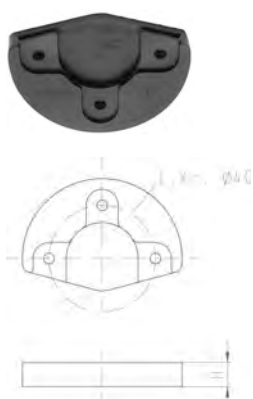

### Sound proofing for pipe outlet

H (mm)	Code	SP	Weight (kg)
11	<b>762 101 033</b>	10	0.011



### Sound proofing for pipe outlet

Single or double

	Code	SP	Weight (kg)
Set single	<b>762 101 036</b>	5	0.077
Set double	<b>762 101 037</b>	2	0.123

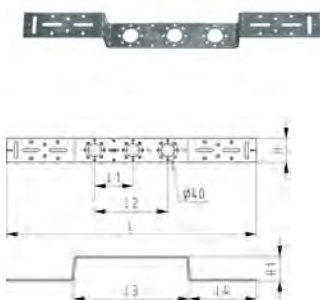

### Angular plate

With hole circle 40 and thread M 6  
From the INSTAFLEX range  
\* suitable also for GIS

L (mm)		Code	SP	Weight (kg)	L1 (mm)	L2 (mm)	L3 (mm)	L4 (mm)	H (mm)	H1 (mm)
370	single	<b>760 869 917</b>	5	0.461			80	145	50	51
470	double	<b>760 869 916</b>	5	0.566	100		180	145	50	51
*	triple	<b>760 869 915</b>	5	0.601	80	153	233	145	50	51
*	double	<b>760 856 042</b>	5	0.600		153	233	145	50	51





### Distance plate - flat

With hole circle 40 and thread M6  
From the INSTAFLEX range

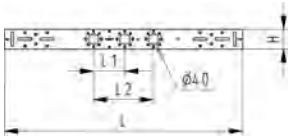

L (mm)		Code	SP	Weight (kg)	L1 (mm)	L2 (mm)	H (mm)
452	single	<b>760 869 920</b>	5	0.464			50
552	double	<b>760 869 919</b>	5	0.564	100		50
605	triple	<b>760 869 918</b>	5	0.624	80	153	50



### Distance plate for dry lined walls

Lightweight construction walls  
With hole circle 40 and thread M6

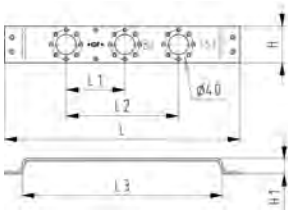

L (mm)	Code	SP	Weight (kg)	L1 (mm)	L2 (mm)	L3 (mm)	H (mm)	H1 (mm)
321	<b>760 869 921</b>	5	0.374	80	153	273	50	21



### GIS distance plate for dry lined walls

With hole circle 40 and thread M6  
From the INSTAFLEX range

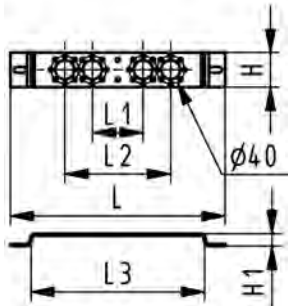

L (mm)	Code	SP	Weight (kg)	L1 (mm)	L2 (mm)	L3 (mm)	H (mm)	H1 (mm)
310	<b>760 855 133</b>	1	0.292	80	153	250	50	21



### Fastening disc

For lightweight construction walls - single fitting connection/double fitting connection - 1/2" thread

Including screws

From the INSTAFLEX range

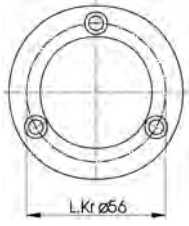

Code	SP	Weight (kg)
------	----	----------------

<b>760 856 204</b>	2	0.050
--------------------	---	-------

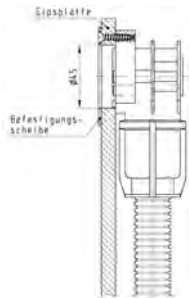
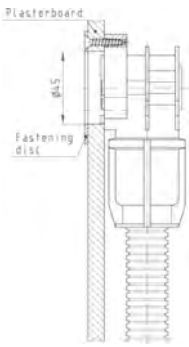

# WC connection modules



## WC connection module concealed

Incl. plastic union nut  
\* low lead

	d (mm)	Rp (inch)	Code	SP	Weight (kg)	G (inch)	L (mm)	H (mm)	h (mm)
	16 - 20	½	<b>762 101 023</b>	5	0.147	1	14	17	41
*	16 - 20	½	<b>762 101 262</b>	5	0.147	1	14	17	41

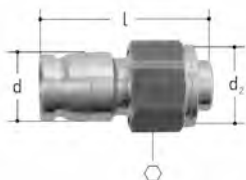
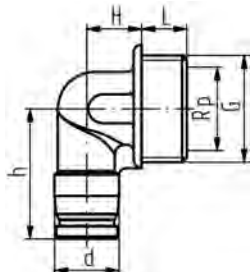

## Pipe outlet module for MeplaFix

Incl. protection cap  
\* low lead

	d (mm)	d2 (inch)	Code	SP	Weight (kg)	L (mm)	⬡
	16 - 20	½	<b>762 101 026</b>	1	0.060	53	24
*	16 - 20	½	<b>762 101 264</b>	1	0.060	53	24



## Pipe outlet elbow module for MeplaFix

Incl. protection cap  
\* low lead

	d (mm)	d2 (inch)	Code	SP	Weight (kg)	L (mm)	h (mm)	⬡
	16 - 20	½	<b>762 101 025</b>	5	0.085	45	34	24
*	16 - 20	½	<b>762 101 263</b>	5	0.085	45	34	24

# Manifolds



## Manifold module

\* low lead

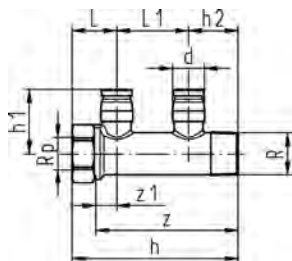

	d (mm)	Rp (inch)	R outlet (inch)		Code	SP	Weight (kg)
	16 - 20	3/4	3/4	2-fold	<b>762 101 230</b>	2	0.315
	16 - 20	3/4	3/4	3-fold	<b>762 101 231</b>	2	0.444
	16 - 20	3/4	3/4	4-fold	<b>762 101 232</b>	2	0.573
*	16 - 20	3/4	3/4	2-fold	<b>762 101 294</b>	2	0.315
*	16 - 20	3/4	3/4	3-fold	<b>762 101 295</b>	2	0.444
*	16 - 20	3/4	3/4	4-fold	<b>762 101 296</b>	2	0.573

	d (mm)	Rp (inch)	R outlet (inch)	h (mm)	h1 (mm)	h2 (mm)	L (mm)	L1 (mm)	z (mm)	z1 (mm)	
	16 - 20	3/4	3/4	2-fold	123	40	35	33	55	109	19
	16 - 20	3/4	3/4	3-fold	178	40	35	33	55	164	19
	16 - 20	3/4	3/4	4-fold	233	40	35	33	55	219	19
*	16 - 20	3/4	3/4	2-fold	123	40	35	33	55	109	19
*	16 - 20	3/4	3/4	3-fold	178	40	35	33	55	164	19
*	16 - 20	3/4	3/4	4-fold	233	40	35	33	55	219	19



## Manifold module with center-to-center distance of 45 mm

\* low lead  
\*\* on request

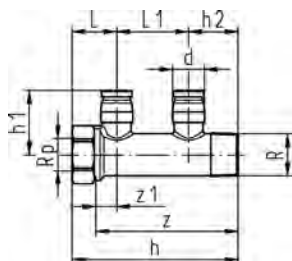

	outlet	d (mm)	Rp (inch)	R (inch)	Code	SP	Weight (kg)
**	2-fold	16 - 20	3/4	3/4	<b>762 101 048</b>	2	0.267
*,**	2-fold	16 - 20	1	1	<b>762 101 209</b>	2	0.436

	L (mm)	L1 (mm)	h (mm)	h1 (mm)	h2 (mm)	z (mm)	z1 (mm)
**	28	45	104	40	31	90	14
*,**	37	60	131	45	34	120	26

## Manifold module PPSU



	d1 (mm)	d2 (mm)	outlet	Code	SP	Weight (kg)	L (mm)	l1 (mm)	l2 (mm)	H (mm)
	25 - 32	16 - 20	3-fold	<b>762 101 213</b>	2	0.052	103	46	40	77
	25 - 32	16 - 20	4-fold	<b>762 101 212</b>	2	0.056	103	46	40	77

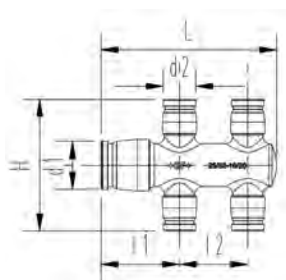

# Accessories for manifolds

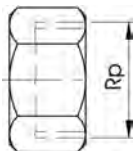

## Cap

From the INSTAFLEX range

Rp (inch)	Code	SP	Weight (kg)
3/4	<b>760 853 794</b>	5	0.084
1	<b>760 853 706</b>	5	0.135

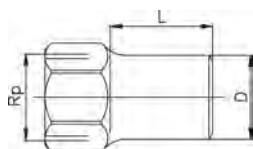

## Cap long

From the INSTAFLEX range

Rp (inch)	Code	SP	Weight (kg)	D (mm)	L (mm)
3/4	<b>760 853 596</b>	5	0.162	27	34

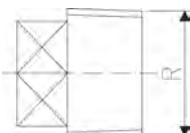

## Plug

From the INSTAFLEX range

R (inch)	Code	SP	Weight (kg)
3/4	<b>760 853 792</b>	5	0.050
1	<b>760 853 793</b>	5	0.084

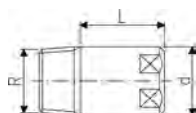

## Plug long

From the INSTAFLEX range

R (inch)	Code	SP	Weight (kg)	D (mm)	L (mm)
3/4	<b>760 869 989</b>	5	0.150	27	52

# Heating assortment



**Connecting elbow module - single**

d (mm)	Code	SP	Weight (kg)	h (mm)	h1 (mm)
16 - 20	<b>762 101 064</b>	5	0.174	330	84



**Connecting elbow module - double**

d1 (mm)	d2 (mm)	Code	SP	Weight (kg)	h (mm)	h1 (mm)	h2 (mm)	L (mm)
16 - 20	16 - 20	<b>762 101 065</b>	5	0.237	30	330	30	60

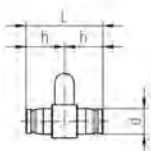
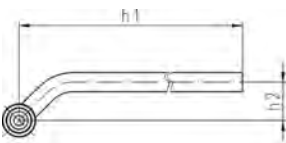

**Cross Tee module**

With isolation box

d (mm)	Code	SP	Weight (kg)	L (mm)	L1 (mm)	H (mm)	H1 (mm)	H2 (mm)
16 - 20	<b>762 101 068</b>	1	0.877	50	50	63	66	46





# iFIT

## Tools



# Tools



## Tool set for ML- and PB pipes

d16 / d20 with pipe scissor, d25 / d32 with pipe cutter

d (mm)	Code	SP	Weight (kg)
16 / 20	<b>762 101 122</b>	1	1.163
25 / 32	<b>762 101 133</b>	1	1.371



## Chamfering tool for ML- and PB pipes

d (mm)	Code	SP	Weight (kg)
16	<b>762 101 116</b>	1	0.188
20	<b>762 101 120</b>	1	0.205
25	<b>762 101 125</b>	1	0.252
32	<b>762 101 132</b>	1	0.323



## Pipe shears d16-d20 for ML- and PB pipes

Also for cutting of protective pipe

d (mm)	Code	SP	Weight (kg)
16 / 20	<b>762 101 108</b>	1	0.322
Spare blades	<b>762 101 109</b>	1	0.014



## Pipe cutter d16-d32 for ML- and PB pipes

d (mm)	Code	SP	Weight (kg)
16 - 32	<b>762 101 117</b>	1	0.386
Spare blades	<b>762 101 118</b>	1	0.005



## Outside pipe bending tool for ML pipes

d (mm)	Code	SP	Weight (kg)
16	<b>762 101 112</b>	1	0.442
20	<b>762 101 113</b>	1	0.541
25	<b>762 101 114</b>	1	0.636
32	<b>762 101 115</b>	1	0.798

# Code Index

# Index

Code	Page	Code	Page	Code	Page	Code	Page
1025.240	62	1810.560	62	350 872 101	62	748 440 707	71, 99
1025.320	62	1810.640	62	350 896 244	61	748 440 708	71, 99
1025.400	62	1810.720	62	350 896 245	61	748 440 709	71, 99
1303.015	61	1810.800	62	350 896 246	61	748 440 710	71, 99
1303.020	61	1830.400	63	350 896 247	61	748 440 711	71, 99
1303.025	61	1830.480	63	350 896 248	61	748 440 712	71, 99
1303.032	61	1830.560	63	350 896 249	61	748 440 713	71, 99
1303.040	61	1830.640	63	350 898 302	62	749 400 005	98
1303.050	61	199 039 001	58	351 110 365	63	749 400 006	98
1303.065	61	199 039 002	58	351 110 500	63	749 400 007	98
1611.015	61	199 039 003	58	355 632 424	141	749 400 008	98
1611.020	61	199 039 004	58	709 026 106	98, 119	749 400 009	98
1611.025	61	199 039 005	58	709 026 203	130	749 400 010	98
1611.032	61	199 039 006	58	709 026 206	130	749 400 011	98
1611.040	61	199 039 007	58	709 026 211	131	749 400 012	98
1611.050	61	199 039 008	58	709 026 214	131	749 400 013	98
1611.065	62	199 039 027	59	709 026 220	131	749 440 706	71, 99
167 547 012	164	199 039 028	59	709 026 223	131	749 440 707	71, 99
167 547 041	165	199 039 029	59	709 026 230	131	749 440 708	71, 99
167 547 042	165	199 039 030	59	709 026 233	131	749 440 709	71, 99
167 547 311	165	199 039 031	59	709 026 242	131	749 440 710	71, 99
167 547 312	165	199 039 032	59	709 026 245	131	749 440 711	71, 99
167 547 512	166	199 039 033	59	709 026 254	131	749 440 712	71, 99
167 547 812	164	199 039 034	59	709 026 257	131	749 440 713	71, 99
167 547 902	166	199 039 201	58	709 026 266	131	760 000 091	55
167 582 502	60	199 039 202	58	709 026 269	131	760 000 092	55
167 582 503	60	199 039 203	58	709 026 278	131	760 000 093	55
167 582 504	60	199 039 204	58	709 026 281	131	760 000 094	55
167 582 505	60	199 039 205	58	709 026 290	131	760 000 095	55
167 582 506	60	199 039 206	58	709 026 293	131	760 000 096	55
167 582 507	60	199 039 207	58	709 026 302	131	760 000 337	57
167 582 512	60	199 039 208	58	709 026 305	131	760 000 338	57
167 582 513	60	199 039 227	59	709 026 314	131	760 000 339	57
167 582 514	60	199 039 228	59	709 026 317	131	760 000 340	57
167 582 515	60	199 039 229	59	709 026 326	131	760 000 341	57
167 582 516	60	199 039 230	59	709 026 329	131	760 000 342	57
167 582 517	60	199 039 231	59	709 026 338	131	760 000 343	55
173 061 005	42	199 039 232	59	709 026 340	131	760 000 344	55
173 061 006	42	199 039 233	59	709 026 341	131	760 000 345	55
173 061 007	42	199 039 234	59	709 026 350	131	760 000 346	55
173 061 008	42	350 599 405	62	709 026 353	131	760 000 347	55
173 061 009	42	350 599 505	62	709 026 362	131	760 000 348	55
173 061 010	42	350 599 606	62	709 026 365	131	760 069 663	92
173 061 011	42	350 690 001	63	709 026 408	131	760 809 081	148
173 061 012	42	350 690 002	63	709 026 409	131	760 809 084	148
173 061 013	42	350 690 003	63	709 026 410	131	760 809 085	148
173 061 014	42	350 690 004	63	709 026 411	131	760 809 086	148
173 061 155	43	350 712 301	61	709 026 413	131	760 809 100	148
173 061 156	43	350 712 401	61	709 026 414	131	760 853 013	76
173 061 157	43	350 712 501	61	7306.080	63	760 853 014	76
173 061 158	43	350 712 601	61	7306.160	63	760 853 018	127
173 061 159	43	350 712 701	61	748 400 004	98	760 853 019	127
173 061 160	43	350 712 801	61	748 400 005	98	760 853 021	127
173 061 161	43	350 734 701	61	748 400 006	98	760 853 022	131
173 061 162	43	350 870 901	62	748 400 007	98	760 853 038	76
173 061 163	43	350 871 001	62	748 400 008	98	760 853 059	76
173 061 164	43	350 871 101	62	748 400 009	98	760 853 071	127
1810.160	62	350 871 201	62	748 400 010	98	760 853 072	127
1810.240	62	350 871 301	62	748 400 011	98	760 853 104	122
1810.320	62	350 871 401	62	748 400 012	98	760 853 105	122
1810.400	62	350 871 501	62	748 400 013	98	760 853 107	123
1810.480	62	350 871 601	62	748 440 706	71, 99	760 853 108	123

# Index

Code	Page	Code	Page	Code	Page	Code	Page
760 853 110	127	760 854 716	125	760 856 241	123	761 065 274	99
760 853 113	123	760 854 717	125	760 856 242	123	761 065 275	99
760 853 114	123	760 854 819	122	760 856 243	123	761 065 276	99
760 853 124	123	760 854 838	122	760 856 244	123	761 065 277	99
760 853 125	124	760 854 839	122	760 856 245	123	761 065 278	99
760 853 131	124	760 854 840	122	760 856 246	123	761 065 279	100
760 853 136	124	760 854 841	124	760 856 247	123	761 065 280	100
760 853 137	124	760 854 842	122	760 856 248	122	761 065 281	100
760 853 138	123	760 854 843	122	760 856 261	122	761 065 283	98, 119
760 853 139	123	760 854 855	126	760 856 262	122	761 065 290	37
760 853 140	124	760 854 860	126	760 856 263	123	761 065 291	37
760 853 150	127	760 854 861	126	760 856 264	123	761 065 292	37
760 853 151	123	760 854 862	126	760 856 602	39	761 065 297	91
760 853 153	122	760 854 863	126	760 856 603	39	761 065 299	91
760 853 180	126	760 854 882	79	760 856 604	39	761 065 300	91
760 853 181	126	760 854 883	79	760 856 605	39	761 065 301	91
760 853 182	126	760 854 884	79	760 856 606	37	761 065 302	91
760 853 189	126	760 854 886	79	760 856 607	37	761 065 303	53
760 853 190	126	760 854 892	126	760 856 608	37	761 065 304	92
760 853 194	122	760 854 906	144	760 856 609	37	761 065 305	92
760 853 195	123	760 854 910	37	760 856 610	37	761 065 307	92
760 853 196	123	760 854 916	144	760 856 611	37	761 065 308	92
760 853 197	123	760 854 917	144	760 856 612	37	761 065 309	92
760 853 198	123	760 854 928	39	760 856 613	37	761 065 310	92
760 853 199	123	760 854 929	39	760 856 614	37	761 065 311	92
760 853 254	41, 41	760 854 930	39	760 856 615	37	761 065 312	92
760 853 278	40	760 854 946	37	760 856 624	37	761 065 313	91
760 853 279	141	760 854 951	41, 41	760 869 902	76	761 066 031	60
760 853 283	39, 40	760 854 984	39, 40	760 869 904	77	761 066 032	60
760 853 284	39, 40	760 854 985	39	760 869 906	76	761 066 033	60
760 853 291	79, 175	760 854 986	39	760 869 914	75	761 066 034	60
760 853 297	79, 175	760 854 988	38, 39	760 869 915	176	761 066 035	60
760 853 298	79, 175	760 854 989	38, 39	760 869 916	176	761 066 036	60
760 853 299	38, 41	760 854 994	148	760 869 917	176	761 066 100	71
760 853 300	38, 41	760 855 133	177	760 869 918	177	761 066 101	71
760 853 316	39	760 856 010	77	760 869 919	177	761 066 102	71
760 853 387	37	760 856 011	78	760 869 920	177	761 066 103	71
760 853 388	37	760 856 013	78	760 869 921	177	761 066 104	71
760 853 389	37	760 856 021	75	760 869 950	144	761 066 105	71
760 853 390	37	760 856 022	75	760 869 987	125	761 066 124	71, 98
760 853 395	37	760 856 023	75	760 869 989	128, 181	761 066 125	71, 98
760 853 397	37	760 856 025	75	760 869 990	128	761 066 126	71, 98
760 853 398	37	760 856 027	75	760 869 991	122	761 066 127	71, 98
760 853 399	38, 40, 40	760 856 029	75	761 065 255	88, 118	761 066 128	71, 98
760 853 527	128	760 856 036	76	761 065 256	88, 118	761 066 129	71, 98
760 853 567	41, 41	760 856 037	76	761 065 257	88, 118	761 066 188	71
760 853 596	128, 181	760 856 040	131	761 065 258	118	761 066 250	93
760 853 627	41	760 856 041	76	761 065 259	118	761 066 251	93
760 853 628	42	760 856 042	176	761 065 260	118	761 066 252	93
760 853 683	175	760 856 043	76	761 065 261	87, 118	761 066 253	93
760 853 706	127, 181	760 856 045	76	761 065 262	87, 118	761 066 254	93
760 853 743	144	760 856 049	78	761 065 263	87, 118	761 066 295	107
760 853 753	39	760 856 050	76	761 065 264	94, 119	761 066 296	42
760 853 786	131	760 856 204	178	761 065 265	94, 119	761 066 297	42
760 853 792	128, 181	760 856 205	77	761 065 266	94, 119	761 066 298	42
760 853 793	128, 181	760 856 211	124	761 065 267	90	761 066 299	42
760 853 794	127, 181	760 856 231	122	761 065 268	90	761 066 300	42
760 854 677	175	760 856 232	122	761 065 269	90	761 066 301	42
760 854 682	76	760 856 233	122	761 065 270	99	761 066 302	42
760 854 699	77, 176	760 856 234	122	761 065 271	99	761 066 303	42
760 854 700	123	760 856 235	122	761 065 272	99	761 066 304	42
760 854 711	124	760 856 236	122	761 065 273	99	761 066 305	42

# Index

Code	Page	Code	Page	Code	Page	Code	Page
761 066 309	107	761 066 645	115	761 066 746	108	761 066 925	107
761 066 310	107	761 066 646	115	761 066 747	108	761 066 926	107
761 066 326	70	761 066 647	115	761 066 748	108	761 066 938	109
761 066 328	54	761 066 648	115	761 066 749	108	761 066 940	115
761 066 337	56	761 066 649	115	761 066 750	139	761 066 941	115
761 066 338	56	761 066 650	108	761 066 751	137	761 066 942	115
761 066 339	56	761 066 651	108	761 066 756	138	761 066 943	115
761 066 340	56	761 066 652	108	761 066 757	138	761 066 944	115
761 066 341	56	761 066 653	108	761 066 758	138	761 066 945	115
761 066 342	56	761 066 654	108	761 066 759	138	761 066 946	56
761 066 343	55	761 066 655	108	761 066 760	138	761 066 947	56
761 066 344	55	761 066 656	108	761 066 761	138	761 066 948	56
761 066 345	55	761 066 660	108	761 066 762	138	761 066 949	56
761 066 346	55	761 066 661	108	761 066 794	141	761 066 950	56
761 066 347	55	761 066 662	108	761 066 795	141	761 066 951	56
761 066 348	55	761 066 663	108	761 066 796	144	761 066 971	72
761 066 558	71, 98	761 066 664	108	761 066 797	144	761 066 972	72
761 066 600	106	761 066 665	108	761 066 799	145	761 066 973	72
761 066 601	106	761 066 666	108	761 066 800	142	761 066 974	72
761 066 602	106	761 066 667	108	761 066 801	138	761 066 980	72
761 066 603	106	761 066 668	108	761 066 802	139	761 068 000	113
761 066 604	106	761 066 669	108	761 066 804	137	761 068 003	113
761 066 605	106	761 066 670	108	761 066 836	141	761 068 004	113
761 066 606	106	761 066 671	108	761 066 843	144	761 068 005	113
761 066 607	106	761 066 672	108	761 066 844	144	761 068 006	113
761 066 608	106	761 066 674	108	761 066 845	144	761 068 007	113
761 066 609	106	761 066 675	108	761 066 846	144	761 068 008	113
761 066 610	106	761 066 677	108	761 066 877	137	761 068 009	113
761 066 611	106	761 066 678	108	761 066 881	138	761 068 010	113
761 066 612	106	761 066 679	108	761 066 882	138	761 068 011	113
761 066 613	106	761 066 681	108	761 066 883	138	761 068 012	113
761 066 614	106	761 066 682	108	761 066 894	137	761 068 013	113
761 066 615	106	761 066 683	108	761 066 895	137	761 068 014	113
761 066 616	106	761 066 684	108	761 066 896	53	761 068 015	113
761 066 617	106	761 066 686	108	761 066 897	53	761 068 016	113
761 066 618	106	761 066 687	108	761 066 898	53	761 068 017	113
761 066 619	106	761 066 688	108	761 066 899	54	761 068 018	113
761 066 620	107	761 066 689	108	761 066 900	106	761 068 019	113
761 066 621	107	761 066 690	108	761 066 901	106	761 068 020	113
761 066 622	107	761 066 691	68	761 066 902	106	761 068 021	113
761 066 623	107	761 066 692	68	761 066 903	106	761 068 022	113
761 066 624	107	761 066 693	68	761 066 904	106	761 068 023	113
761 066 625	107	761 066 694	68	761 066 905	106	761 068 024	113
761 066 626	107	761 066 695	68	761 066 906	106	761 068 025	113
761 066 627	107	761 066 696	68	761 066 907	107	761 068 026	113
761 066 628	107	761 066 697	68	761 066 908	107	761 068 027	138
761 066 629	107	761 066 698	69	761 066 909	107	761 068 028	138
761 066 630	115	761 066 699	69	761 066 910	107	761 068 029	138
761 066 631	115	761 066 700	69	761 066 911	107	761 068 030	138
761 066 632	115	761 066 701	69	761 066 912	107	761 068 031	138
761 066 633	115	761 066 702	69	761 066 913	107	761 068 032	138
761 066 634	115	761 066 703	69	761 066 914	107	761 068 033	138
761 066 635	115	761 066 704	69	761 066 915	107	761 068 034	138
761 066 636	115	761 066 705	69	761 066 916	107	761 068 035	138
761 066 637	115	761 066 706	69	761 066 917	107	761 068 036	138
761 066 638	115	761 066 707	69	761 066 918	107	761 068 037	138
761 066 639	115	761 066 708	69	761 066 919	107	761 068 038	138
761 066 640	115	761 066 709	69	761 066 920	107	761 068 039	139
761 066 641	115	761 066 710	69	761 066 921	107	761 068 040	139
761 066 642	115	761 066 711	69	761 066 922	107	761 068 049	107
761 066 643	115	761 066 742	108	761 066 923	107	761 068 050	107
761 066 644	115	761 066 745	108	761 066 924	107	761 068 051	107

# Index

Code	Page	Code	Page	Code	Page	Code	Page
761 068 052	109	761 069 255	88	761 069 408	68	761 069 513	97, 112
761 068 053	109	761 069 256	88	761 069 409	68	761 069 514	97, 112
761 069 001	135	761 069 257	88	761 069 410	68	761 069 515	97, 112
761 069 006	135	761 069 258	88	761 069 411	68	761 069 516	97, 112
761 069 008	135	761 069 259	88	761 069 412	68	761 069 517	97, 112
761 069 011	134	761 069 260	88	761 069 413	68	761 069 518	95, 110
761 069 012	134	761 069 261	88	761 069 447	87	761 069 519	95, 110
761 069 013	134	761 069 262	88	761 069 448	87	761 069 520	95, 110
761 069 015	134	761 069 263	88	761 069 449	87	761 069 521	95, 110
761 069 016	135	761 069 264	88	761 069 450	87	761 069 522	95, 110
761 069 020	134	761 069 265	86	761 069 451	87	761 069 523	95, 110
761 069 021	134	761 069 266	86	761 069 452	87	761 069 524	95, 110
761 069 200	86	761 069 267	86	761 069 453	87	761 069 525	95, 110
761 069 201	86	761 069 270	89	761 069 454	96, 111	761 069 526	95, 110
761 069 202	86	761 069 271	89	761 069 455	96, 111	761 069 527	95, 110
761 069 203	86	761 069 272	89	761 069 456	96, 111	761 069 528	95, 110
761 069 204	86	761 069 273	89	761 069 457	89	761 069 529	95, 110
761 069 205	86	761 069 274	89	761 069 458	89	761 069 530	95, 110
761 069 206	86	761 069 275	89	761 069 459	89	761 069 531	95, 110
761 069 207	87	761 069 276	89	761 069 460	89	761 069 532	95, 110
761 069 208	87	761 069 277	89	761 069 461	89	761 069 533	95, 110
761 069 209	87	761 069 278	89	761 069 462	89	761 069 534	95, 110
761 069 210	87	761 069 279	89	761 069 463	89	761 069 535	95, 110
761 069 211	87	761 069 280	89	761 069 464	89	761 069 555	86
761 069 212	87	761 069 281	89	761 069 465	89	761 069 556	86
761 069 213	87	761 069 282	89	761 069 475	69	761 069 557	86
761 069 214	86	761 069 283	89	761 069 476	69	761 069 589	91
761 069 215	86	761 069 284	89	761 069 477	69	761 069 590	91
761 069 216	86	761 069 285	89	761 069 478	69	761 069 591	91
761 069 217	86	761 069 286	89	761 069 479	69	761 069 592	91
761 069 218	86	761 069 287	89	761 069 480	69	761 069 599	91
761 069 219	86	761 069 288	90	761 069 481	69	761 069 600	91
761 069 220	86	761 069 289	90	761 069 482	69	761 069 601	91
761 069 221	86	761 069 290	90	761 069 483	69	761 069 602	144
761 069 222	86	761 069 291	90	761 069 484	69	761 069 604	95, 110
761 069 223	86	761 069 306	94	761 069 485	69	761 069 605	95, 110
761 069 227	87	761 069 307	94	761 069 486	69	761 069 606	95, 110
761 069 228	87	761 069 308	94	761 069 487	69	761 069 607	95, 110
761 069 229	87	761 069 309	94	761 069 488	69	761 069 608	95, 110
761 069 230	87	761 069 310	94	761 069 490	90	761 069 609	95, 110
761 069 231	87	761 069 311	94	761 069 491	90	761 069 610	95, 110
761 069 232	87	761 069 312	94	761 069 492	90	761 069 611	95, 110
761 069 233	87	761 069 313	94	761 069 493	90	761 069 612	95, 110
761 069 234	87	761 069 314	94	761 069 494	90	761 069 613	95, 110
761 069 235	87	761 069 315	94	761 069 495	90	761 069 614	95, 110
761 069 236	87	761 069 321	94	761 069 496	90	761 069 615	95, 110
761 069 237	88	761 069 322	94	761 069 497	90	761 069 619	95, 110
761 069 238	88	761 069 323	94	761 069 498	90	761 069 620	95, 110
761 069 239	88	761 069 324	94	761 069 499	90	761 069 621	95, 110
761 069 240	88	761 069 325	94	761 069 500	97, 112	761 069 622	139
761 069 241	88	761 069 326	94	761 069 501	97, 112	761 069 623	90
761 069 242	88	761 069 327	94	761 069 502	97, 112	761 069 624	90
761 069 243	88	761 069 328	94	761 069 503	97, 112	761 069 625	90
761 069 244	88	761 069 329	94	761 069 504	97, 112	761 069 626	90
761 069 245	88	761 069 400	68	761 069 505	97, 112	761 069 627	57
761 069 246	88	761 069 401	68	761 069 506	97, 112	761 069 628	57
761 069 249	88	761 069 402	68	761 069 507	97, 112	761 069 629	57
761 069 250	88	761 069 403	68	761 069 508	97, 112	761 069 630	57
761 069 251	88	761 069 404	68	761 069 509	97, 112	761 069 631	57
761 069 252	88	761 069 405	68	761 069 510	97, 112	761 069 632	57
761 069 253	88	761 069 406	68	761 069 511	97, 112	761 069 641	70
761 069 254	88	761 069 407	68	761 069 512	97, 112	761 069 642	70



# Index

Code	Page	Code	Page	Code	Page	Code	Page
761 069 643	70	761 069 707	66	761 070 263	91	762 101 048	180
761 069 644	70	761 069 708	66	761 070 264	91	762 101 050	160
761 069 645	70	761 069 709	66	761 070 304	51	762 101 051	169
761 069 646	70	761 069 710	66	761 070 305	51	762 101 052	169
761 069 647	50	761 069 711	66	761 070 306	51	762 101 055	169
761 069 648	50	761 069 712	66	761 070 307	51	762 101 056	168
761 069 649	50	761 069 713	66	761 070 308	51	762 101 064	182
761 069 650	50	761 069 714	66	761 070 309	51	762 101 065	182
761 069 651	50	761 069 715	66	761 070 310	52	762 101 068	182
761 069 652	50	761 069 716	66	761 070 311	52	762 101 070	173
761 069 653	50	761 069 717	66	761 070 312	52	762 101 071	174
761 069 654	50	761 069 718	66	761 070 313	52	762 101 076	158
761 069 655	50	761 069 719	66	761 070 314	52	762 101 078	158
761 069 656	50	761 069 720	67	761 070 315	52	762 101 082	158
761 069 657	50	761 069 721	67	761 070 316	52	762 101 086	158
761 069 658	50	761 069 722	67	761 070 317	52	762 101 088	168
761 069 659	51	761 069 723	67	761 070 318	52	762 101 089	170
761 069 660	51	761 069 724	67	761 070 319	140	762 101 090	158
761 069 661	51	761 069 725	67	761 070 320	140	762 101 091	168
761 069 662	92	761 069 726	67	761 070 321	141	762 101 092	168
761 069 665	92	761 069 727	67	761 070 322	140	762 101 093	168
761 069 666	65	761 069 728	67	761 070 323	140	762 101 094	168
761 069 667	65	761 069 729	67	761 070 324	141	762 101 095	168
761 069 668	65	761 069 730	67	761 070 325	145	762 101 096	168
761 069 669	65	761 069 731	67	762 101 000	157	762 101 097	168
761 069 670	65	761 069 732	67	762 101 001	157	762 101 098	168
761 069 671	65	761 069 733	67	762 101 003	158	762 101 099	169
761 069 672	65	761 069 734	67	762 101 004	158	762 101 100	169
761 069 673	65	761 069 735	67	762 101 005	158	762 101 101	169
761 069 674	65	761 069 736	67	762 101 006	158	762 101 102	169
761 069 675	65	761 069 737	67	762 101 007	158	762 101 103	169
761 069 676	65	761 069 738	89	762 101 008	158	762 101 104	158
761 069 677	65	761 069 739	89	762 101 011	157	762 101 105	169
761 069 678	65	761 069 740	96, 111	762 101 012	157	762 101 108	185
761 069 679	65	761 069 741	96, 111	762 101 013	157	762 101 109	185
761 069 680	65	761 069 742	96, 111	762 101 014	157	762 101 112	185
761 069 681	65	761 069 743	96, 111	762 101 017	160	762 101 113	185
761 069 682	65	761 069 744	96, 111	762 101 018	173	762 101 114	185
761 069 683	65	761 069 745	96, 111	762 101 019	173	762 101 115	185
761 069 684	67	761 069 746	96, 111	762 101 022	174	762 101 116	185
761 069 685	67	761 069 747	96, 111	762 101 023	179	762 101 117	185
761 069 686	67	761 069 748	96, 111	762 101 024	158	762 101 118	185
761 069 687	67	761 069 749	96, 111	762 101 025	179	762 101 120	185
761 069 688	67	761 069 750	96, 111	762 101 026	179	762 101 122	185
761 069 689	67	761 069 751	96, 111	762 101 027	160	762 101 125	185
761 069 690	67	761 069 752	96, 111	762 101 030	160	762 101 126	157
761 069 691	67	761 069 753	96, 111	762 101 031	160	762 101 127	157
761 069 692	67	761 069 754	96, 111	762 101 032	158	762 101 128	157
761 069 693	67	761 069 755	96, 111	762 101 033	176	762 101 130	157
761 069 694	67	761 069 756	96, 111	762 101 034	160	762 101 131	157
761 069 695	67	761 069 757	96, 111	762 101 035	160	762 101 132	185
761 069 696	67	761 069 758	114	762 101 036	176	762 101 133	185
761 069 697	67	761 069 759	114	762 101 037	176	762 101 150	159
761 069 698	67	761 069 760	114	762 101 038	168	762 101 151	159
761 069 699	67	761 069 761	114	762 101 039	168	762 101 152	159
761 069 700	67	761 069 762	114	762 101 040	168	762 101 153	159
761 069 701	67	761 069 763	114	762 101 041	168	762 101 154	159
761 069 702	66	761 069 764	114	762 101 042	162	762 101 155	159
761 069 703	66	761 069 765	114	762 101 043	158	762 101 160	157
761 069 704	66	761 070 036	71, 98	762 101 044	161	762 101 161	157
761 069 705	66	761 070 037	71, 98	762 101 046	161	762 101 162	157
761 069 706	66	761 070 038	71, 98	762 101 047	174	762 101 163	157

# Index

Code	Page	Code	Page	Code	Page
762 101 175	161	762 101 269	174	779 812 011	129
762 101 177	161	762 101 270	169	779 812 012	129
762 101 179	161	762 101 271	169	779 812 013	129
762 101 180	162	762 101 272	169	779 812 014	129
762 101 181	162	762 101 273	168	779 812 015	129
762 101 183	163	762 101 274	173	779 812 016	129
762 101 185	163	762 101 275	174	779 812 017	129
762 101 187	163	762 101 276	168	779 812 018	129
762 101 190	170	762 101 277	168	779 812 019	129
762 101 191	170	762 101 278	168	779 812 020	129
762 101 192	170	762 101 279	168	779 812 021	129
762 101 193	170	762 101 280	168	779 812 022	129
762 101 194	158	762 101 281	168	779 812 023	129
762 101 195	158	762 101 282	168	779 862 026	130
762 101 201	157	762 101 283	168	779 862 027	130
762 101 202	162	762 101 284	168	779 862 034	130
762 101 203	162	762 101 285	169	779 864 026	130
762 101 204	163	762 101 286	169	779 864 027	130
762 101 205	163	762 101 287	169	779 864 034	130
762 101 207	171	762 101 288	169	779 901 303	130
762 101 208	171	762 101 289	169	790 109 001	141
762 101 209	180	762 101 290	169	790 109 002	141
762 101 210	170	762 101 292	170	790 109 003	141
762 101 211	170	762 101 293	170	790 109 011	140
762 101 212	180	762 101 294	180	790 109 012	140
762 101 213	180	762 101 295	180	790 109 013	140
762 101 224	171	762 101 296	180	790 114 028	145
762 101 225	171	766 066 975	72	790 115 024	143
762 101 226	172	766 066 976	72	790 136 007	142
762 101 227	167	779 809 001	129	790 136 012	142
762 101 228	167	779 809 002	129	790 136 015	142
762 101 229	167	779 809 003	129	790 143 001	143
762 101 230	180	779 809 004	129	790 143 003	143
762 101 231	180	779 809 005	129	790 143 005	143
762 101 232	180	779 809 006	129	761 069 007	136
762 101 233	163	779 809 007	129	799 298 023	142
762 101 234	38, 159	779 809 008	129	799 298 024	142
762 101 235	38, 39, 159	779 809 009	129		
762 101 236	38, 159	779 809 010	129		
762 101 237	38, 159	779 809 011	129		
762 101 238	160	779 809 012	129		
762 101 240	173	779 809 013	129		
762 101 241	173	779 809 014	129		
762 101 242	173	779 809 015	129		
762 101 250	170	779 809 016	129		
762 101 251	170	779 809 017	129		
762 101 252	170	779 809 018	129		
762 101 253	170	779 809 019	129		
762 101 254	170	779 809 020	129		
762 101 255	170	779 809 021	129		
762 101 256	170	779 809 022	129		
762 101 257	170	779 809 023	129		
762 101 259	173	779 812 001	129		
762 101 260	173	779 812 002	129		
762 101 261	174	779 812 003	129		
762 101 262	179	779 812 004	129		
762 101 263	179	779 812 005	129		
762 101 264	179	779 812 006	129		
762 101 265	168	779 812 007	129		
762 101 266	168	779 812 008	129		
762 101 267	168	779 812 009	129		
762 101 268	168	779 812 010	129		





# General Condition of Supply of Georg Fischer Piping Systems Limited, Schaffhausen

## 1 General

- 1.1 These General Conditions shall apply to all Products supplied by Georg Fischer Piping Systems Limited («Georg Fischer») to the Purchaser.  
They shall also apply to all future business even when no express reference is made to them.
- 1.2 Any deviating or supplementary conditions especially Purchaser's general conditions of purchase and verbal agreements shall only be applicable if accepted in writing by Georg Fischer.
- 1.3 The written form shall be deemed to be fulfilled by all forms of transmission, evidenced in the form of text, such as telefax, e-mail, etc.

## 2 Tenders

- Tenders shall only be binding if they contain a specifically stated period for acceptance.

## 3 Scope of Delivery

- 3.1 Georg Fischer's product range is subject to change.
- 3.2 The confirmation of order shall govern the scope and execution of the contract.

## 4 Data and Documents

- 4.1 Technical documents such as drawings, descriptions, illustrations and data on dimensions, performance and weight as well as the reference to standards are for information purposes only. They are not warranted characteristics and are subject to change.
- 4.2 All technical documents shall remain the exclusive property of Georg Fischer and may only be used for the agreed purposes or as Georg Fischer may consent.

## 5 Confidentiality, Protection of Personal Data

- 5.1 Each party shall keep in strict confidence all commercial or technical information relating to the business of the other party, of which it has gained knowledge in the course of its dealing with the other party. Such information shall neither be disclosed to third parties nor used for other purposes than those for which the information has been supplied.
- 5.2 In the context of the contractual relation with the Purchaser personal data may be processed. The Purchaser agrees to the disclosure of said data to third parties such as foreign subcontractors and suppliers etc.

## 6 Local Laws and Regulations, Export Controls

- 6.1 The Purchaser shall bring to the attention of Georg Fischer all local laws and regulations at the place of destination which bear connection with the execution of the contract and the adherence to relevant safety regulations and approval procedures.
- 6.2 In case of re-exports, Purchaser shall be responsible for compliance with pertinent export control regulations.

## 7 Price

- 7.1 Unless agreed otherwise, the prices shall be deemed quoted net ex works (according to Incoterms 2010 of the ICC, or latest version) including standard packing. All supplementary costs such as the cost of carriage, insurance, export-, transit- and import- licences etc. shall be borne by the Purchaser. The Purchaser shall also bear the costs of all taxes, fees, duties etc. connected with the contract.
- 7.2 If the costs of packing, carriage, insurance, fees and other supplementary costs are included in the tender price or contract price or are referred to specifically in the tender or confirmation of order, Georg Fischer reserve the right to revise their prices accordingly should any change occur in the relevant tariffs.

## 8 Terms of Payment

- 8.1 The Purchaser shall make payment in the manner agreed by the parties without any deductions such as discounts, costs, taxes or dues.
- 8.2 The Purchaser may only withhold or off-set payments due against counter claims which are either expressly acknowledged by Georg Fischer or finally awarded to the Purchaser.  
In particular, payment shall still be made when unessential items are still outstanding provided that the Products already delivered are not rendered unusable as a result.

## 9 Retention of Title

- 9.1 The Products shall remain the property of Georg Fischer until the Purchaser shall have settled all claims, present and future, which Georg Fischer may have against him.
- 9.2 Should the Purchaser resell Products to which title is reserved, in the ordinary course of business, he shall hereby be deemed to have tacitly assigned to Georg Fischer the proceeds deriving from their sale together with all collateral rights, securities and reservations of title until all claims held by Georg Fischer shall have been settled. Until revoked by Georg Fischer, this assignment shall not preclude Purchaser's right to collect the assigned receivables.
- 9.3 To the extent the value of the Products to which title is reserved together with collateral securities exceeds Georg Fischer's claims against the Purchaser by more than 20%, Georg Fischer shall re-assign the above proceeds to Purchaser at his request.

## 10 Delivery

- 10.1 The term of delivery shall commence as soon as the contract has been entered into, all official formalities such as import and payment permits have been obtained and all essential technical issues have been settled. The term of delivery shall be deemed duly observed when, upon its expiry, the Products are ready for despatch.
- 10.2 Delivery is subject to the following conditions, i.e. the term of delivery shall be reasonably extended:
  - a) if Georg Fischer are not supplied in time with the information necessary for the execution of the contract or if subsequent changes causing delays are made by the Purchaser.
  - b) if Georg Fischer are prevented from performing the contract by force majeure. Force majeure shall equally be deemed to be any unforeseeable event beyond Georg Fischer's control which renders Georg Fischer's performance commercially unpractical or impossible, such as delayed or defective supplies from sub contractors labour disputes, governmental orders or regulations, shortages in materials or energy, serious disturbances in Georg Fischer's works, such as the total or partial destruction of plant and equipment or the breakdown of essential facilities, serious disruptions in transport facilities, e.g. impassable roads.  
Should the effect of force majeure exceed a period of six (6) months, either party may cancel the contract forthwith.  
Georg Fischer shall not be liable for any damage or loss of any kind whatsoever resulting from the reform, any suspension or cancellation being without prejudice to Georg Fischer's right to recover all sums due in respect of consignments delivered and costs incurred to date.
  - c) if the Purchaser is in delay with the fulfilment of his obligations under the contract, in particular, if he does not adhere to the agreed conditions of payment or if he has failed to timely provide the agreed securities.
- 10.3 If for reasons attributable to Georg Fischer the agreed term of delivery or a reasonable extension thereof is exceeded, Georg Fischer shall not be deemed in default until the Purchaser has granted to Georg Fischer in writing a reasonable extension thereof of not less than one (1) month which equally is not met.  
The Purchaser shall then be entitled to the remedies provided at law, it being however understood that, subject to limitations of Art. 16, damage claims shall be limited to max. 10% of the price of the delayed delivery.
- 10.4 Part shipments shall be allowed and Georg Fischer shall be entitled to invoice for such partial deliveries.
- 10.5 If the Purchaser fails to take delivery within a reasonable time of Products notified as ready for despatch, Georg Fischer shall be entitled to store the Products at the Purchaser's expense and risk and to invoice them as delivered. If Purchaser fails to effect payment, Georg Fischer shall be entitled to dispose of the Products.
- 10.6 Should Purchaser cancel an order without justification and should Georg Fischer not insist on the performance of the contract, Georg Fischer shall be entitled to a penalty amounting to 10% of the contract price, Georg Fischer's right to prove and claim higher damages remaining reserved.

Purchaser shall be entitled to prove, that Georg Fischer has suffered no or a considerably lower damage than the penalty forfeited.

## 11 Packing

- If the Products are provided with additional packing over and above the standard packing, such packing shall be charged additionally.

## 12 Passing of Risk

- 12.1 The risk in the Products shall pass to the Purchaser as soon as they have left Georg Fischer's works (EX WORKS, Incoterms 2010 ICC, or latest version), even if delivery is made carriage-paid, under similar clauses or including installation or when carriage is organized and managed by Georg Fischer.
- 12.2 If delivery is delayed for reasons beyond Georg Fischer's control, the risk shall pass to the Purchaser when he is notified that the Products are ready for despatch.

## 13 Carriage and Insurance

- 13.1 Unless agreed otherwise, the Purchaser shall bear the cost of carriage.
  - 13.2 The Purchaser shall be responsible for transport insurance against damage of whatever kind. Even when such insurance is arranged by Georg Fischer it shall be deemed taken out by the order of and for the account of the Purchaser and at his risk.
  - 13.3 Special requests regarding carriage and insurance shall be communicated to Georg Fischer in due time. Otherwise carriage shall be arranged by Georg Fischer at their discretion, but without responsibility, by the quickest and cheapest method possible.  
In case of carriage-paid delivery transport arrangements shall be made by Georg Fischer. If the Purchaser specifies particular requirements, any extra costs involved shall be borne by him.
  - 13.4 In the event of damage or loss of the Products during carriage the Purchaser shall mark the delivery documents accordingly and immediately have the damage ascertained by the carrier. Not readily ascertainable damages sustained during carriage shall be notified to the carrier within six (6) days after receipt of the Products.
- ## 14 Inspection, Notification of Defects and Damages
- 14.1 The Products will be subject to normal inspection by Georg Fischer during manufacture. Additional tests required by the Purchaser shall be agreed upon in writing and shall be charged to the Purchaser.
  - 14.2 It shall be a condition of Georg Fischer's obligation under the warranties stated hereinafter that Georg Fischer be notified in writing by the Purchaser of any purported defect immediately upon discovery. Notice concerning weight, numbers or apparent defects is to be given latest within 30 days from receipt of the Products, notice of other defects immediately latest within seven (7) working days after discovery, in any event within the agreed warranty period.
  - 14.3 Purchaser shall not dispose of allegedly defective Products until all warranty and/or damage claims are finally settled. At its request, defective Products are to be placed at Georg Fischer's disposal.
  - 14.4 At its request, Georg Fischer shall be given the opportunity to inspect the defect and/or damage, prior to commencement of remedial work, either itself or by third party experts.

## 15 Warranty

- 15.1 At the written request of the Purchaser, Georg Fischer undertakes to repair or replace at its discretion, as quickly as possible and free of charge, all Products supplied which demonstrably suffer from faulty design, materials or workmanship, from faulty operating or installation instructions or which become defective or unusable due to faulty advice.  
In order to protect employees from toxic or radioactive substances which may have been transported through defective parts returned to Georg Fischer's sales organisation, said parts must be accompanied by a Material Safety Disclosure Form. The form may be obtained from Georg Fischer's local sales company or via [www.piping.georgfischer.com](http://www.piping.georgfischer.com).  
Replaced parts shall become property of Georg Fischer, unless Georg Fischer waives such claim.
- 15.2 For Products which are manufactured to specifications, drawings or patterns supplied by the Purchaser, Georg Fischer's warranty shall be restricted to proper materials and workmanship.
- 15.3 The Purchaser shall be entitled to rescind the contract or to demand a reduction of the contract price if
  - the repair or replacement of the defective Product is impossible
  - the defective Product is not repaired or replaced within a reasonable period
  - Georg Fischer refuses the repair or replacement or if for reasons attributable to Georg Fischer the repair or replacement is delayed.
- 15.4 For Products or essential components manufactured by a third party and supplied by Georg Fischer under this contract, Georg Fischer's warranty is limited to the warranty provided by said third party.
- 15.5 This warranty shall not apply to damage resulting from normal wear and tear, improper storage and maintenance, failure to observe the operating instructions, overstressing or overloading, unsuitable operating media, unsuitable construction work or unsuitable building ground, improper repairs or alterations by the Purchaser or third parties, the use of other than original spare parts and other reasons beyond Georg Fischer's control.
- 15.6 No action or claim may be brought by the Purchaser on account of any alleged breach of warranty or any other obligation of Georg Fischer after the expiration of twelve (12) months from receipt of the Products by the end user or at the latest within eighteen (18) months of the Products being despatched by Georg Fischer.
- 15.7 In case of Products for use in domestic installations or in utilities
  - Georg Fischer will assume the costs of dismantling the defective Product and restoring the damaged object up to CHF 1'000'000 per occurrence.
  - warranty or damage claims - contrary to Section 15.6 - are time-barred five (5) years from the date of installation or seven (7) years from the production date, whichever is earlier.

## 16 Limitation of Liability

- The rights and remedies of the customer shall be exclusively governed by these General Conditions of Supply and shall be in lieu of any remedies at law. All further claims for damages, reduction of the purchase price, termination of or rescission of the contract are excluded.  
In no case whatsoever shall the customer be entitled to claim damages other than compensation for costs of remedying defects in the supplies. This in particular refers, but shall not be limited, to loss of production, loss of use, loss of orders, loss of profit, third party recovery claims and other direct or indirect or consequential damages.  
This limitation of liability equally applies to the extent Georg Fischer is liable for acts or omissions of its employees or third parties engaged for the performance of its obligations. It does not apply in case of unlawful intent or gross negligence on the part of Georg Fischer's management and in case of Georg Fischer's statutory liability, in particular under applicable product liability laws.

## 17 Severability

- Should any term or clause of these General Conditions in whole or in part be found to be unenforceable or void, all other provisions shall remain in full force and effect and the unenforceable or void provision shall be replaced by a valid provision, which comes closest to the original intention of the unenforceable or invalid provision.

## 18 Place of Performance and Jurisdiction

- 18.1 Place of performance for the Products shall be the Georg Fischer works from which the Products are despatched.
- 18.2 The contract shall be governed by Swiss law without regard to conflict of law provisions that would require the application of another law.
- 18.3 Any civil action based upon any alleged breach of this contract shall be filed and prosecuted exclusively in the courts of Schaffhausen, Switzerland.  
Georg Fischer however reserves the right to file actions in any court having jurisdiction over controversies arising out of or in connection with the present contract.

# Worldwide at home

Our sales companies and representatives ensure local customer support in over 100 countries.

[www.gfps.com](http://www.gfps.com)

## Argentina / Southern South America

Georg Fischer Central Plastics  
Sudamérica S.R.L.  
Buenos Aires, Argentina  
Phone +5411 4512 02 90  
Fax +5411 4512 02 93  
[gfcentral.ps.ar@georgfischer.com](mailto:gfcentral.ps.ar@georgfischer.com)  
[www.gfps.com/ar](http://www.gfps.com/ar)

## Australia

George Fischer Pty Ltd  
Riverwood NSW 2210  
Phone +61 (0)2 9502 8000  
Fax +61 (0)2 9502 8090  
[australia.ps@georgfischer.com](mailto:australia.ps@georgfischer.com)  
[www.gfps.com/au](http://www.gfps.com/au)

## Austria

Georg Fischer Rohrleitungssysteme GmbH  
3130 Herzogenburg  
Phone +43 (0) 2782 856 43 0  
Fax +43 (0) 2782 856 64  
[austria.ps@georgfischer.com](mailto:austria.ps@georgfischer.com)  
[www.gfps.com/at](http://www.gfps.com/at)

## Belgium / Luxembourg

Georg Fischer NV/SA  
1070 Bruxelles/Brüssel, Belgium  
Phone +32 (0)2 556 40 20  
Fax +32 (0)2 524 34 26  
[be.ps@georgfischer.com](mailto:be.ps@georgfischer.com)  
[www.gfps.com/be](http://www.gfps.com/be)

## Brazil

Georg Fischer Sist. de Tub. Ltda.  
04571-020 São Paulo/SP  
Phone +55 (0)11 5525 1311  
[br.ps@georgfischer.com](mailto:br.ps@georgfischer.com)  
[www.gfps.com/br](http://www.gfps.com/br)

## Canada

Georg Fischer Piping Systems Ltd  
Mississauga, ON L5T 2B2  
Phone +1 (905) 670 8005  
Fax +1 (905) 670 8513  
[ca.ps@georgfischer.com](mailto:ca.ps@georgfischer.com)  
[www.gfps.com/ca](http://www.gfps.com/ca)

## China

Georg Fischer Piping Systems Ltd  
201319 Shanghai  
Phone +86 21 3899 3899  
Fax +86 21 3899 3888  
[china.ps@georgfischer.com](mailto:china.ps@georgfischer.com)  
[www.gfps.com/cn](http://www.gfps.com/cn)

## Denmark / Iceland

Georg Fischer A/S  
2630 Taastrup, Denmark  
Phone +45 (0) 7022 1975  
Fax +45 (0) 7022 1976  
[info.dk.ps@georgfischer.com](mailto:info.dk.ps@georgfischer.com)  
[www.gfps.com/dk](http://www.gfps.com/dk)

## Finland

Georg Fischer AB  
01510 Vantaa  
Phone +358 (0)9 586 58 25  
Fax +358 (0)9 586 58 29  
[info.fi.ps@georgfischer.com](mailto:info.fi.ps@georgfischer.com)  
[www.gfps.com/fi](http://www.gfps.com/fi)

## France

Georg Fischer SAS  
95932 Roissy Charles de Gaulle Cedex  
Phone +33 (0)1 41 84 68 84  
Fax +33 (0)1 41 84 68 85  
[fr.ps@georgfischer.com](mailto:fr.ps@georgfischer.com)  
[www.gfps.com/fr](http://www.gfps.com/fr)

## Germany

Georg Fischer GmbH  
73095 Albershausen  
Phone +49 (0)7161 302 0  
Fax +49 (0)7161 302 25 9  
[info.de.ps@georgfischer.com](mailto:info.de.ps@georgfischer.com)  
[www.gfps.com/de](http://www.gfps.com/de)

## India

Georg Fischer Piping Systems Pvt. Ltd.  
400 076 Powai, Mumbai  
Phone +91 22 4007 2001  
Fax +91 22 4007 2020  
[branchoffice@georgfischer.com](mailto:branchoffice@georgfischer.com)  
[www.gfps.com/in](http://www.gfps.com/in)

## Indonesia

Georg Fischer Representative Office  
10310 Jakarta  
Phone +62 21 391 48 62  
Fax +62 21 391 48 63  
[sgp.ps@georgfischer.com](mailto:sgp.ps@georgfischer.com)  
[www.gfps.com/sg](http://www.gfps.com/sg)

## Italy

Georg Fischer S.p.A.  
20063 Cernusco S/N (MI)  
Phone +39 02 921 86 1  
Fax +39 02 921 86 24 7  
[it.ps@georgfischer.com](mailto:it.ps@georgfischer.com)  
[www.gfps.com/it](http://www.gfps.com/it)

## Japan

Georg Fischer Ltd  
556-0011 Osaka  
Phone +81 (0)6 6635 2691  
Fax +81 (0)6 6635 2696  
[jp.ps@georgfischer.com](mailto:jp.ps@georgfischer.com)  
[www.gfps.com/jp](http://www.gfps.com/jp)

## Korea

Georg Fischer Piping Systems  
463-824 Seoul  
Phone +82 31 8017 1450 3  
Fax +82 31 8017 1454  
[kor.ps@georgfischer.com](mailto:kor.ps@georgfischer.com)  
[www.gfps.com/kr](http://www.gfps.com/kr)

## Malaysia

Georg Fischer (M) Sdn. Bhd. Sales Office  
40460 Shah Alam, Selangor Darul Ehsan  
Phone +60 (0)3 5122 5585  
Fax +60 (0)3 5122 5575  
[my.ps@georgfischer.com](mailto:my.ps@georgfischer.com)  
[www.gfps.com/my](http://www.gfps.com/my)

## Mexico / Northern Latin America

Georg Fischer S.A. de C.V.  
Apodaca, Nuevo Leon, Mexico  
Phone +52 (81) 1340 8586  
Fax +52 (81) 1522 8906  
[mx.ps@georgfischer.com](mailto:mx.ps@georgfischer.com)  
[www.gfps.com/mx](http://www.gfps.com/mx)

## Middle East

Georg Fischer  
Piping Systems (Switzerland) Ltd  
Dubai, United Arab Emirates  
Phone +971 4 289 49 60  
Fax +971 4 289 49 57  
[gss.ps@georgfischer.com](mailto:gss.ps@georgfischer.com)  
[www.gfps.com/int](http://www.gfps.com/int)

## Netherlands

Georg Fischer N.V.  
8161 PA Epe  
Phone +31 (0) 578 678 222  
Fax +31 (0) 578 621 768  
[nl.ps@georgfischer.com](mailto:nl.ps@georgfischer.com)  
[www.gfps.com/nl](http://www.gfps.com/nl)

## New Zealand

Georg Fischer Ltd  
5140 Upper Hutt  
Phone +64 (0) 4 527 9813  
Fax +64 (0) 4 527 9834  
[nz.ps@georgfischer.com](mailto:nz.ps@georgfischer.com)  
[www.gfps.com/nz](http://www.gfps.com/nz)

## Norway

Georg Fischer AS  
1351 Rud  
Phone +47 67 18 29 00  
Fax +47 67 13 92 92  
[no.ps@georgfischer.com](mailto:no.ps@georgfischer.com)  
[www.gfps.com/no](http://www.gfps.com/no)

## Philippines

Georg Fischer Representative Office  
1604 Pasig City  
Phone +632 571 2365  
Fax +632 571 2368  
[sgp.ps@georgfischer.com](mailto:sgp.ps@georgfischer.com)  
[www.gfps.com/sg](http://www.gfps.com/sg)

## Poland

Georg Fischer Sp. z o.o.  
05 090 Sekocin Nowy  
Phone +48 (0)22 3131 050  
Fax +48 (0)22 3131 060  
[poland.ps@georgfischer.com](mailto:poland.ps@georgfischer.com)  
[www.gfps.com/pl](http://www.gfps.com/pl)

## Romania

Georg Fischer Rohrleitungssysteme (Elvetia)  
S.A. SUCURSALA BUCURESTI  
020257 Bucuresti  
Phone +40 311 040 492  
Fax +40 212 317 479  
[ro.ps@georgfischer.com](mailto:ro.ps@georgfischer.com)  
[www.gfps.com/int](http://www.gfps.com/int)

## Russia

Georg Fischer  
Piping Systems (Switzerland) Ltd  
Moscow Representative Office  
125040 Moscow  
Phone +7 495 748 11 44  
[ru.ps@georgfischer.com](mailto:ru.ps@georgfischer.com)  
[www.gfps.com/ru](http://www.gfps.com/ru)

## Singapore

Georg Fischer Pte Ltd  
528 872 Singapore  
Phone +65 6747 0611  
Fax +65 6747 0577  
[sgp.ps@georgfischer.com](mailto:sgp.ps@georgfischer.com)  
[www.gfps.com/sg](http://www.gfps.com/sg)

## Spain / Portugal

Georg Fischer S.A.  
28046 Madrid  
Phone +34 (0) 91 781 98 90  
Fax +34 (0) 91 426 08 23  
[es.ps@georgfischer.com](mailto:es.ps@georgfischer.com)  
[www.gfps.com/es](http://www.gfps.com/es)

## Sweden

Georg Fischer AB  
11743 Stockholm  
Phone +46 (0) 8 506 77 50 0  
Fax +46 (0) 8 749 23 70  
[info.se.ps@georgfischer.com](mailto:info.se.ps@georgfischer.com)  
[www.gfps.com/se](http://www.gfps.com/se)

## Switzerland

Georg Fischer  
Rohrleitungssysteme (Switzerland) AG  
8201 Schaffhausen  
Phone +41 (0)52 631 30 26  
Fax +41 (0)52 631 28 00  
[ch.ps@georgfischer.com](mailto:ch.ps@georgfischer.com)  
[www.gfps.com/ch](http://www.gfps.com/ch)

## Taiwan

Georg Fischer Co. Ltd.  
24158 New Taipei City  
Phone +886 2 8512 2822  
Fax +886 2 8512 2823  
[tw@georgfischer.com](mailto:tw@georgfischer.com)  
[www.gfps.com/tw](http://www.gfps.com/tw)

## Turkey

Georg Fischer Hakan Plastik  
Boru ve Profil San. Tic. A.S.  
59500 Cerkezoy / Tekirdag  
Phone +90 282 726 64 43  
Fax +90 282 726 94 67  
[hpsales@hakan.com.tr](mailto:hpsales@hakan.com.tr)  
[www.hakan.com.tr](http://www.hakan.com.tr)

## United Kingdom / Ireland

Georg Fischer Sales Ltd  
CV2 2ST Coventry, United Kingdom  
Phone +44 (0) 2476 535 535  
Fax +44 (0) 2476 530 450  
[uk.ps@georgfischer.com](mailto:uk.ps@georgfischer.com)  
[www.gfps.com/uk](http://www.gfps.com/uk)

## USA / Caribbean

Georg Fischer LLC  
92618 Irvine  
Phone +1 714 731 88 00  
Fax +1 714 731 62 01  
Toll Free 800/854 40 90  
[us.ps@georgfischer.com](mailto:us.ps@georgfischer.com)  
[www.gfpiping.com](http://www.gfpiping.com)

## International

Georg Fischer  
Piping Systems (Switzerland) Ltd  
8201 Schaffhausen/Switzerland  
Phone +41 (0) 52 631 30 03  
Fax +41 (0) 52 631 28 93  
[info.export@georgfischer.com](mailto:info.export@georgfischer.com)  
[www.gfps.com/int](http://www.gfps.com/int)

The technical data are not binding. They neither constitute expressly warranted characteristics nor guaranteed properties nor a guaranteed durability. They are subject to modification. Our General Terms of Sale apply.

